

T900- 2023-Q01-2026
February 5, 2026



**INVITATION TO BID
PUBLIC WORKS
PROJECT NUMBER
SW-C2023A**

PROJECT MANUAL

FOR

LAGOON, SHORELINE AND STREAM RESTORATION

AT

TWANOH STATE PARK

IN

MASON COUNTY

BID OPENING: 1:00 P.M., TUE, APRIL 07, 2026.

**Bidders are required to submit bid prices electronically through the State
Parks Public Opportunities-MRSC Bonfire Procurement Portal**

<https://mrscrosters.bonfirehub.com>

****BIDS WILL BE OPENED WITHIN THREE BUSINESS DAYS****

**WASHINGTON STATE PARKS & RECREATION COMMISSION
300 DESMOND DR SE
LACEY WA 98503
POST OFFICE BOX 42650
OLYMPIA, WASHINGTON 98504-2650**



PROJECT MANUAL

FOR

LAGOON, SHORELINE AND STREAM RESTORATION

AT

TWANOH STATE PARK

IN

MASON COUNTY



1/21/2026

PROJECT ENGINEER

Approved for Construction

Heather Saunders

Heather Saunders, Director of Parks Development

WASHINGTON STATE PARKS AND RECREATION COMMISSION

300 DESMOND DR SE

LACEY WA 98503

P.O. BOX 42650

OLYMPIA, WASHINGTON 98504-2650

TWANOH STATE PARK
LAGOON, SHORELINE AND STREAM RESTORATION

“ADVERTISEMENT FOR BID” LETTER

INVITATION TO BID.....	i-iii
INSTRUCTIONS TO BIDDERS	19 pages
SUPPLEMENTAL INSTRUCTIONS TO BIDDERS	5 pages
BID PROPOSAL FORM.....	9 pages
SUMMARY OF PAY ITEMS AND QUANTITIES.....	2 pages
SUPPLEMENTAL RESPONSIBILITY CRITERIA.....	11 pages
GENERAL CONDITIONS	43 pages
PREVAILING WAGE STATEMENT (STATE & FEDERAL)	1 page
DIVISION 1 – GENERAL REQUIREMENTS	
010000 - General Requirements	5 pages
010099 - Surveying.....	2 pages
013300 - Submittal Procedures	4 pages
013501 - InadvDiscoveryCulturalResSkeletal Remains	5 pages
014000 - Quality Requirements	8 pages
014100 - Regulatory Requirements	2 pages
014200 - References	3 pages
015000 - Temporary Facilities and Controls.....	5 pages
015526 - Traffic Control Optional.....	2 pages
015639 - Temporary Tree and Plant Protection.....	7 pages
016000 - Product Requirements.....	5 pages
017419 - Construction Waste Management	1 page
017700 - Closeout Procedures	4 pages
DIVISION 2 – EXISTING CONDITIONS	
024113 - Selective Site Demolition	3 pages
DIVISION 10 – SPECIALTIES	
100000 - Provide Footbridge, Large Woody Debris, and Beach Gravel	2 pages
DIVISION 31 – EARTHWORK	
311000 - Site Clearing.....	4 pages
312000 - Earth Moving.....	4 pages
DIVISION 32 – EXTERIOR IMPROVEMENTS	
329300 - Landscaping.....	3 pages

END OF SECTION

Diana Dupuis,
Director



STATE OF WASHINGTON
WASHINGTON STATE PARKS AND RECREATION COMMISSION

300 Desmond Dr SE • PO Box 42650 • Olympia, WA 98504-2650 • (360) 902-8500
Internet Address: <http://www.parks.wa.gov>

ADVERTISEMENT FOR BID

Sealed bids will be received for the following project:

PROJECT NUMBER:	SW-C2023A
PROJECT TITLE:	Twanoh State Park – Lagoon, Shoreline, and Stream Restoration
PROJECT DESCRIPTION:	Removing a concrete bulkhead, expanding an existing saltwater lagoon, constructing a tidal channel, re-planting salvaged native vegetation around the fringe of the new lagoon. The project also includes removing existing riprap and several trees along the shoreline and streambanks; naturalizing the shoreline by installing large woody debris, bioengineered softshore armoring and a deformable gravel berm; performing work within Twanoh Creek that includes expanding the floodplain, installing clusters of large woody debris within the stream and floodplain, removing and replacing a pedestrian bridge and abutments, and installing bioengineered streambanks.
PROJECT LOCATION:	Twanoh State Park in Mason County at 12190 E. State Route 106, Union, WA 98592.
ESTIMATED BID RANGE:	\$1,114,650.00 - \$1,362,350.00
PROJECT REPRESENTATIVE:	Deana Bishop
PROCUREMENT COORDINATOR	Jason Bologna
PREBID WALKTHROUGH:	10:00 AM on Thursday, March 19, 2026. Meet at the Boat Launch Parking Lot, located off Northwest Park Entrance from HWY 106.
SUBMITTAL DUE DATE/TIME:	1:00 PM on Tuesday, April 07, 2026.
ELECTRONIC BIDDING:	Bidders are required to register as vendors on the MRSC Bonfire Procurement Portal https://mrscrosters.bonfirehub.com to be eligible to submit bids. All bid submissions must be completed electronically through the State Parks Public Opportunities section of the portal. Bidders must use the official Bid Proposal Form, provided as part of the electronic bid documents, ensuring that all required fields are properly filled out and submitted before the deadline. (See Bonfire support details further down.)

PLANS, SPECIFICATIONS, ADDENDA, AND PLAN HOLDERS LIST: Contractors can access plans and specifications through the State Parks Public Opportunities-MRSC Bonfire Procurement Portal at <https://mrscrosters.bonfirehub.com/portal>.

Important: Bidders are encouraged to “Register as a Prime/GC Interest” on the project details page of the MRSC Rosters Bonfire Procurement Portal to be placed on the Bidders List. This service is free for Prime Bidders, Subcontractors, and Vendors interested in bidding on this project.

Additionally, plans and specifications are available through Builders Exchange Washington, Inc. at <http://www.bxwa.com>. Posted Projects”; “Public Works”, “Washington State Parks and Recreation. Bidders have the option to access Bid Documents, including Specifications and Drawings, at www.parks.wa.gov/contracts by clicking on the Construction Projects link for reference purposes. However, the official channel for bid notifications and addenda is the State Parks Public Opportunities-MRSC Rosters Bonfire Portal, and bidders should rely on it for the most up-to-date information.

PLANS MAY ALSO BE VIEWED THROUGH: Associated Builders And Contractors, Spokane WA; Tri City Construction Council, Kennewick WA; Daily Journal of Commerce, Seattle WA; Weekly Construction Reporter, Bellingham WA; Daily Journal Of Commerce Plan Center, Portland OR; Lower Columbia Contractor Plan Center, Longview WA; Abadan Spokane Plan Center, Spokane WA; ARC Document Solutions, Seattle, WA; Associated General Contractors, Boise, ID; Dodge Construction, Bedford, MA; Hermiston Plan Center, Hermiston, OR; Contractor Plan Center, Clackamas, OR; Wenatchee Plan Center, Wenatchee, WA; Spokane Regional Plan Center, Spokane, WA; Associated General Contractors, Spokane, WA; Walla Walla Valley Plan Center, Walla Wall, WA; Yakima Plan Center, Yakima, WA.

TECHNICAL QUESTIONS regarding this project shall be directed to: Deana Bishop, Project Representative at (360) 725-9757 or deana.bishop@parks.wa.gov.

BID RESULTS will be published on the State Parks Public Opportunities-MRSC Rosters Bonfire Portal <https://mrscrosters.bonfirehub.com/portal> following the bid deadline and in the Construction Projects section at www.parks.wa.gov/contracts after the bid submittal. This practice ensures that those involved and interested can readily view bid outcomes, enhancing transparency and efficiency in the bidding process.

THIS PROJECT IS FUNDED through a federal sub-recipient grant from the [Insert Federal Agency Name, e.g., Emergency Management Division (EMD) of the Washington Military Department]. As part of federal grant oversight, the funding agency must review the bid tabulations and the apparent low bidder prior to award, which may extend the overall timeline for issuing the contract.

DUAL COMPLIANCE PREVAILING WAGES REQUIREMENTS (RCW 39.12 / DAVIS-BACON) apply to this Public Works project funded with federal dollars, both the Washington State Prevailing Wage and the Federal Davis-Bacon Wage requirements apply, and Contractors must pay the higher rate for each classification, with bidders responsible for verifying and using the most recent state wage rates as of the bid submittal date.

BIDDER RESPONSIBILITY will be evaluated for this project. In determining bidder responsibility, the Agency shall consider an overall accounting of the criteria set forth in Division 00 – Supplemental Responsibility Criteria. Please direct questions regarding this subject to the Project Representative.

MANDATORY 15% APPRENTICE LABOR HOURS of the total labor hours are a requirement of this construction contract. Voluntary workforce diversity goals for this apprentice participation are identified in the Instructions to Bidders. Bidders may contact the Department of Labor & Industries, Apprenticeship Section, to obtain information on available apprenticeship programs.

SUBCONTRACTOR LISTINGS: Per RCW 39.30.060, when the bid proposal combined with any alternates totals one million dollars or more, the Bidder must list the Subcontractors they intend to use for structural steel, rebar installation, heating, ventilation, and air conditioning (HVAC), plumbing, and electrical work on the Subcontractor Utilization List form for this project.

ACCESS EQUITY: The successful Bidder is required to complete their vendor registration in Access Equity, a secure B2GNow online vendor management system. Prime Contractors already registered with B2GNow for any public entity must ensure their information is up to date. The system can be accessed either directly at <https://omwbe.diversitycompliance.com/> or via the Office of Minority and Women's Business Enterprises (OMWBE) website at <https://omwbe.wa.gov/>.

FOR THIS PROJECT, VOLUNTARY DIVERSITY GOALS HAVE BEEN SET: 10% for Minority Business Enterprises (MBE), 6% for Women's Business Enterprises (WBE), 5% for Washington Small Businesses, and 5% for Veteran-owned businesses. While meeting these goals is not mandatory, it is strongly encouraged to promote diversity in business participation.

Bidders may contact the Office of Minority and Women's Business Enterprise (OMWBE) at: <http://omwbe.wa.gov/> to obtain information on certified firms. Bidders may also utilize Washington Small Businesses registered in WEBS at <https://pr-webs-vendor.des.wa.gov/> and Veteran-owned Businesses at <https://www.dva.wa.gov/veterans-their-families/veteran-ownedbusinesses/vob-search>.

Washington State Parks reserves the right to accept or reject any or all proposals and to waive informalities.

STATE OF WASHINGTON
PARKS AND RECREATION COMMISSION
CONTRACTS AND GRANTS

For assistance with the Bonfire Vendor Registration Process, please visit the following link: [Vendor Registration Support](#)

For guidance on the Bonfire Bid Submission Process, refer to this link: [Bid Submission Support](#)

Additional Bonfire Vendor Support resources, including support articles and instructional videos, are available at: [Bonfire Vendor Support](#)

If vendors experience any technical issues, they can contact Bonfire Support via email at support.bonfire@eunasolutions.com.

TWANOH STATE PARK
LAGOON, SHORELINE AND STREAM RESTORATION

INVITATION TO BID

1.1 SPECIAL NOTICE(S)

- A. The site will be available for Work on July 6, 2026.
- B. Upon Contract award, a Limited Notice to Proceed will be issued to enable Contractor to begin procurement of materials with long lead times.
- C. The in-water work window for this project occurs from July 16th to January 14th.
- D. This contract has “Buy America” requirements per the Department of the Interior. See Section 016000 – Quality Requirements, for further information.

1.2 DESCRIPTION OF WORK

- A. This project includes: Removing a concrete bulkhead, expanding an existing saltwater lagoon, constructing a tidal channel, re-planting salvaged native vegetation around the fringe of the new lagoon. The project also includes removing existing riprap and several trees along the shoreline and streambanks; naturalizing the shoreline by installing large woody debris, bioengineered softshore armoring and a deformable gravel berm; performing work within Twanoh Creek that includes expanding the floodplain, installing clusters of large woody debris within the stream and floodplain, removing and replacing a pedestrian bridge and abutments, and installing bioengineered streambanks.

1.3 LOCATION OF PROJECT

- A. The project is located at Twanoh State Park in Mason County at 12190 E. State Route 106, Union, WA 98592.

1.4 TECHNICAL QUESTIONS

- A. Direct project questions to:

Deana Bishop, Project Representative at (360) 725-9757, or deana.bishop@parks.wa.gov, 11834 Tilley Road S, Olympia, WA 98512.

1.5 PRE-BID PROJECT SITE TOUR

DATE:	Thursday, March 19, 2026.
TIME:	10:00 A.M.
LOCATION:	Boat Launch Parking Lot, located off Northwest Park Entrance from HWY 106.

TWANOH STATE PARK
LAGOON, SHORELINE AND STREAM RESTORATION

1.6 BID OPENING

- A. Bidders must be registered as vendors through the MRSC Bonfire Procurement Portal <https://mrscrosters.bonfirehub.com/portal>, which is free to sign up for, before submitting their bids electronically through the State Parks Public Opportunities section of the same portal. All bids must be submitted using the Bid Proposal Form, provided as part of the electronic bid documents. Submissions must fully comply with the requirements outlined in Sections 3.1 and 4.1 of the Instructions to Bidders. Bids are due at 1:00 p.m., Tuesday, April 21, 2026. Late submissions will not be accepted.
- B. The Agency does not guarantee a specific timeframe for the public release of bid results; however, they are typically available within three business days of the bid opening, often on the same day. Bid results can be accessed through the MRSC Bonfire Procurement Portal <https://mrscrosters.bonfirehub.com/portal> and public notices. Additionally, they may be available on the Washington State Parks website at www.parks.wa.gov/contracts under "Construction Projects – Public Works Bid Results." Bid results may also be shared through Plan Centers, but Bidders should note that the State Parks Public Opportunities - MRSC Rosters Bonfire Procurement Portal serves as the official release point for the Bid Tabulation or Bid Record for this solicitation.
- C. The Agency reserves the right to accept or reject all bids and to waive informalities. The Bidder will allow 60 days from bid opening date for acceptance of its bid by the Agency.

1.7 COVID 19

- A. COVID-19 Refer to the Department of Labor & Industries website for requirements regarding any safety plans needed. [Novel Coronavirus Outbreak \(COVID-19\) Resources \(wa.gov\)](https://www.dli.wa.gov/COVID-19/COVID-19-Resources)

1.8 FOR INFORMATION ON:

- A. Bidder Responsibility: Bidder responsibility will be evaluated for this project. In determining bidder responsibility, the Agency will consider an overall assessment of the criteria outlined in Division 00 – Instructions to Bidders.

For any questions regarding this topic, please contact the Project Representative or submit a vendor discussion through the State Parks Public Opportunities - MRSC Bonfire Procurement Portal <https://mrscrosters.bonfirehub.com/portal>. To ensure consideration, all inquiries must be received at least seven (7) working days before the bid opening date.

- B. Reciprocal Preference: See Instructions to Bidders 11.1 Reciprocal Preference for Resident Contractors.
- C. Apprenticeship Requirements: For projects estimated at or over \$1,000,000, Apprenticeship Participation, Mandatory 15 percent apprentice labor, see Instructions to Bidders 5.1B Apprenticeship Participation.
- D. Subcontractor Listings: When the base bid combined with any alternates totals

TWANOH STATE PARK
LAGOON, SHORELINE AND STREAM RESTORATION

\$1,000,000 or more, the Bidder must list the Subcontractors they intend to use for structural steel, rebar installation, heating, ventilation, and air conditioning (HVAC), plumbing, and electrical work on the Subcontractor Utilization List form for this project, see Instructions to Bidders 5.1A Subcontractor Listing.

- E. MWBE goals: See Instructions To Bidders 12.1 Minority And Women's Business Enterprise (MWBE) Utilization. For Veteran-Owned and Small Business utilization, see Instruction to Bidders 12.2.
- F. Modification of Bid: See Instructions to Bidders 6.3 Modification of Bid.
- G. Withdrawal of Bid: See Instructions to Bidders 6.4 Withdrawal of Bid.
- H. Bid Guarantee: See Instructions to Bidders 4.1 Bid Bond. No particular bid bond form is required.
- I. Bid Tabulation and Bid Record: See Instructions to Bidders 7.1B for Bid Tabulation, Bid Record, and Announcement of Apparent Low Bid.
- J. Records Request: All submitted bids are subject to public records request once the lowest bidder has been determined and officially announced. See Instructions to Bidders 7.1D Records Request.

1.9 ACCESSIBILITY

- A. Sites may not be fully accessible to people with disabilities. Please contact the Project Representative at least five (5) days prior to scheduled pre-bid tour if special accommodation is required for your attendance.

END OF SECTION

**WASHINGTON STATE PARK AND RECREATION COMMISSION
PUBLIC WORKS PROJECT**

1.1 BIDDER DEFINED

- A. A "*Bidder*" is an entity or person who submits a bid proposal for the work described in the contract documents.
- B. The Bidder must be registered with the Washington State Department of Labor and Industries in accordance with RCW 18.27.020. The contractor registration number, expiration date, Uniform Business Identifier (UBI) number, and federal tax identification number must be entered in the applicable spaces on the Bidder Compliance Form within the Bid Proposal Form.

2.1 EXAMINATION OF THE WORK SITE AND BIDDING DOCUMENTS

- A. Bidder acknowledges that it has taken steps necessary to ascertain the nature and location of the work, and that it has investigated and satisfied itself as to the general and local conditions which can affect the work or its cost, including but not limited to (1) conditions bearing upon transportation, disposal, handling, and storage of materials; (2) the availability of labor, water, electric power, and road; (3) uncertainties of weather, river stages, tides, or similar physical conditions at the site; (4) the conformation and conditions of the ground; and (5) the character of equipment and facilities needed preliminary to and during the work.

The bidder also acknowledges that it has satisfied itself as to character, quality, and quantity of surface and subsurface materials or obstacles to be encountered insofar as this information is reasonably ascertainable from an inspection of the site, including exploratory work done by the Owner, as well as from the drawings and specifications made a part of this contract. Any failure of the Bidder to take the actions described and acknowledged in this paragraph will not relieve the Bidder from responsibility for estimating properly the difficulty and cost of successfully performing the work.

- B. No statement by any officer, agent, or employee of the Owner pertaining to the physical conditions of the site of the work will be binding on the Owner other than those statements issued in the contract documents.
- C. Bidders shall promptly notify the Owner of ambiguities, inconsistencies, or errors, if any, which they may discover upon examination of the Bidding Documents or of the site and local conditions.
- D. Interpretations and Clarifications
 - 1) Prospective Bidders seeking clarification or interpretation of the solicitation, drawings, or specifications must submit a written request to the Project Representative listed in the Invitation to Bid or through the **State Parks Public Opportunities-MRSC Rosters Bonfire Procurement Portal** <https://mrscrosters.bonfirehub.com/portal> by submitting a vendor discussion. Requests must be received at least seven (7) working days prior to the bid deadline to be considered.
 - 2) Any Owner responses that do not modify the Scope of Work outlined in the contract documents may be posted on the State Parks Public Opportunities-MRSC Rosters Bonfire Procurement Portal prior to the bid submission deadline. Such clarifications will not be considered part of the contract documents and do not need to be acknowledged by Bidders in their Bid Proposal Form. The Owner retains sole discretion to determine whether a clarification or interpretation affects the Scope of Work and requires inclusion in the Contract Documents.

**WASHINGTON STATE PARK AND RECREATION COMMISSION
PUBLIC WORKS PROJECT**

- 3) Changes to the Scope of Work or schedule described in the contract documents will only be issued as written ADDENDA.
- 4) Oral interpretations or clarifications are not legally binding.

E. Substitutions

- 1) The product, equipment, materials, or methods described or noted within the Bidding Documents, whether currently available or not, are to establish a standard of quality, function, appearance and dimension. A proposed substitution shall have equal attributes in all respects.
- 2) No substitution will be considered unless a written request for approval is submitted by the Contractor, after Award, in accordance with the applicable provisions of Section 012500 of the specifications. If no Section 012500 is available, then see section 016000 Product Requirements, sub-section 1.5. Each such request shall describe the proposed substitution in its entirety including name of the material or equipment, drawings, catalog cuts, performance or test data and all other information required for an evaluation. The submittal shall also include a statement noting all changes required in adjoining, dependent or other interrelated work necessitated by the incorporation of the proposed substitute. The Bidder shall bear the burden of proof of merit of the proposed substitution. The Project Representative's decision of approval or disapproval of a proposed substitution shall be final.

3.1 BID PROPOSAL

- A. Bidders must be registered as vendors through the **MRSC Rosters Bonfire Procurement Portal** <https://mrscrosters.bonfirehub.com/portal>. All bid submissions must be made through the State Parks Public Opportunities section on the same portal. The individual who signs and submits the bid through the Bonfire Portal must be an authorized designee responsible for the bid submission.
- B. All bidders for Small Works Projects must be currently registered on the MRSC Small Works Roster (vendor list) found <http://mrscrosters.org/>.
- C. Bidders are required to submit bid prices electronically through the **State Parks Public Opportunities-MRSC Rosters Bonfire Procurement Portal**. Submissions must be completed using the Bid Proposal Form, provided as part of the electronic bid proposal documents. The Bid Proposal Form is a spreadsheet consisting of four tabs:
 1. Bidder Compliance Form
 2. Bid Form
 3. MWBE
 4. Subcontractor Utilization (if applicable)

All fields in the Bid Proposal Form tabs must be properly and completely filled out to ensure compliance. Failure to fill in all required fields may result in the bid being deemed non-responsive.

**WASHINGTON STATE PARK AND RECREATION COMMISSION
PUBLIC WORKS PROJECT**

The Bidder Compliance Form must include the Bidder's full and complete address and information, typed in the spaces provided. The Bid Form must be electronically signed in the firm's name, and a typewritten name is acceptable as an electronic signature, provided it complies with electronic submission requirements.

Once the Bid Proposal Form is completed, it must be uploaded in its original form to the appropriate section of the State Parks Public Opportunities-MRSC Rosters Bonfire Procurement Portal <https://mrscrosters.bonfirehub.com/portal>. Bidders are reminded to thoroughly review their submission before uploading to ensure compliance with all instructions and requirements. Incomplete submissions will be deemed non-responsive.

- D. Except as otherwise provided in these instructions, bid proposals that are incomplete, or that are conditioned in any way, or that contain alterations, or items not called for in the contract documents, or that do not conform to the call for bids, may be rejected as non-responsive at the discretion of the Owner unless the law requires that the omission be deemed non-responsive, in which case the bid will be rejected as non-responsive. Only the amounts and information asked for on the Bid Proposal Form and the plans and specifications furnished will be considered as the bid. Bid amounts include all taxes imposed by law, **except** for Washington Sales Tax unless noted otherwise.
- E. Each Bidder must submit their bid exactly as specified and as provided in the Bid Proposal Form. Bidders are required to include bids for all alternates if alternates are indicated on the Bid Form. For alternates that have no charge, the Bidder must type "\$0.00" in the column for the unit price on the Bid Form.
- F. Bidders shall acknowledge receipt of any ADDENDA to the solicitation for bids on the Bid form. Failure to do so may result in the bid being declared non-responsive.
- G. Substitute bid forms will not be considered unless this solicitation authorizes their submission.
- H. The bid prices listed in the Bid Form must include all labor, materials, equipment, overhead, and compensation necessary to complete the work for each item, while the costs for the building permit and public utility hookup fees will either be reimbursed directly to the Contractor or paid by the Owner to the permitting agency and therefore should not be included in the bid amount.
- I. The low Bidder, for purposes of award, shall be the responsive and responsible Bidder offering the low aggregate amount for the base bid item, plus additive or deductive bid alternates selected by the Owner, and within funds available for the project. The Bidder agrees to hold all bid alternate prices for sixty (60) days from date of bid deadline.

4.1 BID GUARANTEE: BID BOND

- A. A bid bond is not required when the total bid amount, including the base bid and all additive alternates, is \$35,000 or less. In such cases, instead of providing a bid bond, Bidders must complete and upload the **Bid Bond Requirement Statement** as part of their bid submission. This ensures compliance with the bidding requirements for projects below the \$35,000 threshold.
- B. When the sum of the base bid plus all additive alternates is greater than \$35,000.00, a bid guarantee in the amount of 5% of the base bid amount is required. Failure of the Bidder to provide bid guarantee when required shall render the bid non-responsive.

**WASHINGTON STATE PARK AND RECREATION COMMISSION
PUBLIC WORKS PROJECT**

- C. Acceptable forms of bid guarantee are: A bid bond. A scanned copy (e.g., PDF) of the bid bond must be uploaded to the State Parks Public Opportunities-MRSC Rosters Bonfire Procurement Portal (<https://mrscrosters.bonfirehub.com/portal>) along with your bid response to the Owner. See also, Section 6.1 SUBMISSION OF BID.
- D. The Bidder will allow 60 days from bid deadline for acceptance of its bid by the Owner.
- E. Should the successful Bidder fail to enter into a contract and furnish a satisfactory performance bond within 15 days after receiving properly prepared contract forms from the Owner, the bid bond may be forfeited as liquidated damages for advertisements and administration of bid procedures. Additionally, the Owner reserves the right to terminate the contract award.
- F. Bid bonds must be held for the three low bids for 30 days or until a contract is executed with the successful Bidder. All other bid bonds will be released or returned to the Bidders within 15 days of the bid deadline.

5.1 REQUIREMENTS FOR PROJECTS ESTIMATED AT \$1,000,000 OR MORE

A. SUBCONTRACTOR LISTING

Pursuant to [RCW 39.30.060](#), if the base bid combined with the sum of the alternates is one million dollars (\$1,000,000.00) or more for the construction, alteration, or repair of any public building or public work of the state, the Bidder shall submit the names of subcontractors with whom the Bidder, if awarded the contract, will subcontract for performance of the work of heating, ventilation and air conditioning (HVAC), plumbing, electrical, structural steel installation, and rebar installation, or to name itself for the work.

1. Submission Deadlines:

- HVAC, Plumbing, and Electrical: The names of subcontractors and proof of license for these trades (or the Bidder's own name and proof of license) must be submitted at the published bid submittal time. Errors identified by the Owner in the proof of license information may be corrected by the Bidder within 48 hours of submission.
 - Structural Steel and Rebar: The names of subcontractors for these trades may be submitted at the published bid submittal time but must be submitted no later than 48 hours after the published bid submittal time.
- 2. The Bidder shall not list more than one subcontractor for each category of work identified, unless subcontractors vary with bid alternates, in which case the Bidder must indicate which subcontractor will be used for which alternate.
 - 3. The Bidder can name itself for the performance of the work. Bidders who name themselves to perform the work are expected to perform the work and the Owner reserves the right to reject substitution of the bidder with a subcontractor unless the bidder demonstrates a change in circumstances from the time of bid submission that is outside of the control of the bidder.
 - 4. The Subcontractor Utilization List is intended to discourage bid shopping, not to verify subcontractor qualifications. The Owner does not use the Subcontractor Utilization List as a tool to disqualify or qualify bidders.
 - 5. Substitution of a listed subcontractor (at any tier) before or after the award of the prime

WASHINGTON STATE PARK AND RECREATION COMMISSION PUBLIC WORKS PROJECT

contract is prohibited except for the following reasons:

- Refusal of the listed subcontractor to sign a contract with the prime contractor,
- Bankruptcy or insolvency of the listed subcontractor,
- Inability of the listed subcontractor to perform the requirements of the proposed contract or the project,
- Inability of the listed subcontractor to obtain the necessary license, bonding, insurance, or other statutory requirements to perform the work detailed in the contract,
- Refusal or inability to provide a letter of bondability from a surety company, or
- The listed subcontractor is barred from participating in the project as a result of a court order.

Subcontractor listing is not required for Small Works Projects under \$350,000.

Failure of the Bidder to submit, the names and license numbers of such subcontractors, or to name itself to perform such work, or the naming of two or more subcontractors to perform the same work, or failure to sign the form shall render the bid as non-responsive and therefore void.

B. APPRENTICESHIP PARTICIPATION

In projects estimated to cost one million dollars (\$1,000,000.00) or more, be aware that the following requirements will be part of the resulting contract.

Apprenticeship requirements do not apply to Small Works Projects estimated below \$350,000.

In accordance with [RCW 39.04.320](#) (Apprenticeship Training Programs), for all public works estimated by the Owner Project Engineer to cost **one million dollars or more**, the state of Washington requires no less than **15% of the labor hours be performed by apprentices**. A contractor or subcontractor may not be required to exceed the 15% requirement. The bid advertisement and Bid Proposal Form shall establish a minimum required percentage of apprentice labor hours compared to the total labor hours. The project's apprenticeship utilization rate is calculated using the approved affidavits from the L&I portal.

1. **Incentives** - The Contractor who meets or exceeds this utilization requirement on eligible contracts, will be awarded a monetary incentive described in the Apprentice Utilization Requirements section of the Bid Proposal Form.
2. **Penalties** - The Contractor who fails to meet the utilization requirement and fails to demonstrate a Good Faith Effort, as outlined below, is subject to penalties described in the Apprentice Utilization Requirements section of the contract Bid Proposal Form. Contractor will receive an invoice payable to the Owner within 30 days. The contractor will have 30 days to pay the penalty invoice at the time of receipt before the penalty is considered outstanding. Contractors with outstanding apprenticeship penalties may be considered non-responsive.
3. **Cost Value** - The expected cost value associated with meeting the goal is included in the Base Bid as described on the Bid Proposal Form.

**WASHINGTON STATE PARK AND RECREATION COMMISSION
PUBLIC WORKS PROJECT**

4. **Utilization Plan** - The Contractor shall provide an Apprentice Utilization Plan (Plan) demonstrating how and when they intend to achieve the Apprenticeship Utilization Requirement. The Plan shall have enough information to track the Contractor's progress in meeting the utilization requirement. The Contractor shall submit the Plan on the Apprentice Utilization Plan template within 10 business days of Notice to Proceed of the contract and prior to submitting the first invoice. The Contractor shall provide an updated Plan during the course of construction when there are significant changes to the Plan which may affect their ability to meet the requirement.
- a) The Plan shall be uploaded to the Department of Labor & Industries' (L&I): ***Prevailing Wage Intents and Affidavit (PWIA) system on L&I's website.***
 - b) The Plan is not submitted for approval.
 - c) It is expected that the Contractor will actively seek out opportunities to meet the Apprentice Utilization Requirement during construction even if the Plan indicates a shortfall in meeting the requirement.
 - d) If the Plan indicates that the Contractor will not attain the Apprentice Utilization Requirement, then Contractor must submit "Good Faith Effort" (GFE) documentation with their Plan to L&I's PWIA system.

C. APPRENTICESHIP - GOOD FAITH EFFORT (GFE)

1. **Good Faith Effort (GFE)** documentation shall describe in detail why the Contractor is not or was not able to attain the Apprentice Utilization Requirement.
- a) Contractors may submit Good Faith Effort (GFE) documentation at any time during the construction.
 - b) All GFE documentation must be submitted no later than 30 days before substantial completion.
 - c) Only the awarding Owner can approve GFEs. The Department of Labor & Industries (L&I) may provide assistance but does not have approval authority
 - d) The Awarding Owner must document its GFE decision in writing, including any monetary penalty if denied.
 - e) Good Faith Effort (GFE) documentation must be in signed letter format uploaded to the PWIA system and include:
 - 1. The contract number, title and the apprentice utilization requirements,
 - 2. The amount of apprentice labor hours the contract can or did attain along with the percentage of labor hours,
 - 3. Contractors may receive a GFE credit for graduated Apprentice hours through the end of the calendar year for all projects worked on as long as the Apprentice remains continuously employed with the same Contractor they were working for when they graduated. If an Apprentice graduates during employment on a project of significant duration, they may be counted towards a GFE credit for up to one year after their graduation or until the end of the project (whichever

**WASHINGTON STATE PARK AND RECREATION COMMISSION
PUBLIC WORKS PROJECT**

comes first). Determination of whether or not Contract requirements were met in good faith will be made by subtracting the hours from the journeyman total reported hours for the project and adding them to the apprentice hour total. If the new utilization percentage meets the Contract requirement, the Contractor will be reported as meeting the requirement in good faith,

4. Anticipated or actual shortfall (in apprentice labor hours and percentage) and the reason(s) for not attaining the required apprentice labor hours,
5. Information from one or more of the following areas:
 - (a) Names of any State-Approved Apprentice Training Programs contacted with the name(s) of person(s) contacted and dates of contacts, and a copy of each response from the Training Program(s),
 - (b) Reference Contract Specifications or documents that affected the Contractor's ability to attain apprentice utilization,
 - (c) Discuss efforts the Contractor has taken to require Subcontractors to solicit and employ apprentices,
6. Backup documentation to the letter consisting of the following:
 - (a) Letters, emails, phone logs including names dates and outcomes, posters, photos, payrolls, timecards, schedules, copies or references to other contract specifications or documents.

Additional Resource Information

- (a) For questions regarding how to complete the Apprentice Utilization Plan template or Good Faith Effort documentation, please contact the Project Manager listed in the Bid Advertisement.
- (b) Step-by-step instructions on how to access and navigate the L&I's PWIA system, including uploading required documents can be found on the L&I website.
- (c) Additional information about apprentice utilization on Public Works Project can be found on the L&I website.

6.1 SUBMISSION OF BID

- A. Bids must be submitted on or before the time as specified in the Invitation to Bid.
- B. Bid responses will only be accepted electronically through the State Parks Public Opportunities section using the MRSC Rosters Bonfire Procurement Portal as specified in the Invitation to Bid. <https://mrscrosters.bonfirehub.com/portal>.
- C. People with disabilities who wish to request special accommodation, (e.g., sign language interpreters, braille, etc.) need to contact the Owner ten (10) working days prior to the scheduled bid deadline.

**WASHINGTON STATE PARK AND RECREATION COMMISSION
PUBLIC WORKS PROJECT**

- D. In the event the MRSC Rosters Bonfire Procurement Portal is unavailable to all users at the bid submittal deadline, the Owner will contact the Bidders within 24 hours and the Owner will extend the bid submittal time.
- E. Neither Owner nor MRSC Rosters Bonfire Procurement Portal can guarantee the availability of Internet connectivity or related telecommunication and hosting services and will not be liable or responsible if the Bidder and its representative(s) or designee(s) cannot connect to the MRSC Rosters Bonfire Procurement Portal.
- F. The Bidder must comply with the MRSC Rosters Bonfire Portal's Terms of Service (<https://gobonfire.com/termservice/>) when submitting the Bid through the MRSC Rosters Bonfire Procurement Portal.

6.2 BID CLOCK:

- A. After the 1 P.M. bid deadline, which serves as the official bid clock to determine timely submission, Owner staff will review the bids. The MRSC Rosters Bonfire Procurement Portal does not permit submissions after the deadline, so bidders must ensure their bids are submitted on time. Late submissions will not be accepted under any circumstances.
- B. CAUTION: To avoid issues, submit your bid response electronically well in advance of the deadline to account for potential technological delays, slow-downs, or malfunctions. Bids received after the deadline, regardless of the reason or responsibility, will be rejected.

6.3 MODIFICATION OF BID

- A. Bidders may update their bid electronically via the MRSC Rosters Bonfire Procurement Portal before the bid due date.

Modifying: Modifying refers to altering information already contained in a submitted bid. If your submission has been finalized but needs modifications, you may update it electronically before the bid due date by navigating to the Submissions page and un-submitting your submission.

NOTE: Un-submitting removes your original bid, so ensure you resubmit before the deadline. Only upload updated files; unchanged files remain in place. A new confirmation email will be sent upon resubmission.

6.4 WITHDRAWAL OF BID

- A. Withdrawal refers to a bid that has already been submitted to the Owner. A bid response may be withdrawn electronically by the Bidder's authorized representative before the Bid Deadline (due date) for the bid. The FAILURE TO WITHDRAW a bid prior to the bid due date deadline exposes the Bidder to the possibility that the Owner will make a demand against the Bidders bid bond.
- B. Procedure for Withdrawing a Bid After Bid Deadline Due to Error: If a Bidder discovers an error in its bid following the bid deadline, the Bidder must submit written notification of the withdrawal to contracts@parks.wa.gov within 24 hours following the bid deadline. Follow the example subject line. Example email subject line: SW-C9999 Withdraw Bid ACME Construction Inc.
 - The Bidder must provide written documentation of the claimed error to the satisfaction of

WASHINGTON STATE PARK AND RECREATION COMMISSION PUBLIC WORKS PROJECT

the Owner within 72 hours following the bid deadline.

- The Owner will approve or disapprove the request for withdrawal of the bid in writing. If the Bidder's request for withdrawal of its bid is approved, the Bidder will be released from further obligation to the Owner without penalty. If it is disapproved, the Owner may retain the Bidder's bid bond.

6.5 REJECTION OF BID

- A. The Owner reserves the right to reject any or all bids and to waive informalities in connection with the bids.

7.1 BID EVALUATION AND AWARD OF CONTRACT

- A. Award of contract will be made by the Owner based upon any combination of the base bid and alternates that, in the Owner's sole discretion, is in the Owner's best interest considering price, schedule, and other factors. The numbering of the alternates in the bid proposal bears no relationship to the order in which the alternates may be selected by the Owner. Additionally, the Owner reserves the right to negotiate base bid prices (including changes to the contract plans and specifications) with the low responsive, responsible Bidder to bring the final contract amount within the funds available per RCW 39.04.015.

- B. **BID TABULATION, BID RECORD AND ANNOUNCEMENT OF APPARENT LOW BID:**

The Owner does not guarantee when the Bid results will be released to the public. The bid results are usually released within three business days of the bid deadline and often the same day. Bid results can be obtained from MRSC Rosters Bonfire Procurement Portal (<https://mrscrosters.bonfirehub.com/portal>) and viewing public notices. Bid Results may also be obtained by accessing the Washington State Parks webpage at www.parks.wa.gov/contracts (see "Construction Projects- Public works bid results"). The Bid results may also be released through the Plan Centers. But, Bidders are cautioned that the State Parks Public Opportunities-MRSC Rosters Bonfire Procurement Portal is the official release point for the Bid Tabulation or Bid Record for this solicitation.

The bid tabulation will identify all bids received by the Owner. Bids that were not rejected and not withdrawn prior to the bid deadline will be ranked by base bid price. The first three lowest base bids will reflect detailed pricing information. The remaining Bidders will reflect only the base bid pricing. Bids that were rejected for any reason will reflect **Non-Responsive** in the bid tabulation but may include its total pricing.

The bid record will list all bids received, ordered alphabetically. Rejected bids will not show detailed pricing. The bid record is used for projects with Alternates. The Owner may consider Alternate Bid Items in any combination. The low Bidder for award purposes is the responsive Bidder offering the lowest aggregate amount for the base bid plus selected alternates, within available project funds.

Release of the Bid Tabulation or Announcement of the Apparent Low bid information that a Firm was identified as the apparent low base bid simply means that at this point in time the Owner believes the subject bid was the lowest cost responsive bid, but designation as the apparent low responsive bid is not a guarantee of a contract with the Owner. The Owner reserves the right to reevaluate the bid and determine whether the bid was responsive and responsible and successful as first thought. The Bidder identified as the apparent low responsive bid is cautioned not to commit funds, resources, and effort prior to receiving an

WASHINGTON STATE PARK AND RECREATION COMMISSION PUBLIC WORKS PROJECT

actual executed contract. The Bidder identified as the apparent low responsive bid that commits funds, resources, and effort prior to a contract do so at its own risk and peril.

Within two (2) business days following the day of the release of the Bid Tabulation/Bid Record or the Announcement of the Apparent Low bid, the Bidder may file a Protest (Protest procedures are outlined in Section 9.1).

- C. REJECTION LETTER & PROTEST: No matter the phase of the evaluation, if the Owner determines that the bid is not responsive or the Bidder is not responsible, the Owner will reject the bid/bidder, and send the bidder a Rejection Letter explaining why the bid/bidder was rejected. Within two (2) business days following the day of the release of the Rejection Letter, the Bidder may file a Protest, provided it meets one of the three (3) protest grounds (Protest procedures are outlined in Section 9.1 E.). The Rejection Letter will be sent by email/email attachment to the email address provided by the Bidder in the Bidder's bid response.
- D. RECORDS REQUEST: All submitted bids are subject to public records request once the lowest bidder has been determined and officially announced.

After the announcement of the lowest bidder, any member of the public may request access to the bid documents. No official format is required for making a records request; however, the Owner recommends that requests be made through the Public Records Request Center on our website: <https://parks.wa.gov/about/contact-us/public-records-requests>.

- E. The intent of the Owner is to award a contract to the low responsive, responsible bidder.

8.1 RESPONSIVE AND RESPONSIBLE BIDDER

- A. The Owner will evaluate bids responsiveness and responsibility in the MRSC Rosters Bonfire Procurement Portal <https://mrscrosters.bonfirehub.com/portal>.
- B. RESPONSIVE - A bid will be considered responsive if its electronic response meets the following requirements:
 - 1. It is received at the proper submittal time, date and location online through the State Parks Public Opportunities-MRSC Rosters Bonfire Procurement Portal.
 - 2. It meets the required requested information of the Bid Proposal Form through the State Parks Public Opportunities-MRSC Rosters Bonfire Procurement Portal.
 - 3. It meets the requirements as stated in section 3.1. of the Instructions To Bidders.
 - 4. It is submitted by a licensed/registered contractor within the state of Washington at the time of bid deadline and is not banned from bidding by the Department of Labor and Industries.
 - 5. It is accompanied by a bid guarantee, if required.

If inconsistencies or errors are noted in the bid proposal prices, the **unit and lump sum prices have precedence over their total amounts**; and the **total amounts have precedence over the total base bid**.

The apparent low Bidder, for purpose of award, is the responsive and responsible Bidder offering the low aggregate amount for the base bid plus selected additive or deductive bid alternates and meeting all other bid submittal requirements.

**WASHINGTON STATE PARK AND RECREATION COMMISSION
PUBLIC WORKS PROJECT**

- C. RESPONSIBLE – Before award of a public works contract, a Bidder must meet the following **mandatory responsibility criteria** under [RCW 39.04.350](#) (1) & (2) to be considered a responsible Bidder and qualified to be awarded a public works project. The individual who has signed/submitted the Bid through the State Parks Public Opportunities-MRSC Rosters Bonfire Procurement Portal shall be the authorized designee responsible for bid submissions. The Bidder must:
1. At the time of bid submittal, have a certificate of registration in compliance with [RCW 18.27](#), a plumbing contractor license in compliance with [RCW 18.106](#), an elevator contractor license in compliance with [RCW 70.87](#), or an electrical contractor license in compliance with [RCW 19.28](#) as required under the provisions of those chapters;
 2. Have a current state Unified Business Identifier (UBI) number;
 3. If applicable, have industrial insurance coverage for the Bidder's employees working in Washington as required in [RCW 51](#); an employment security department number as required in [RCW 50](#); and a state excise tax registration number as required in [RCW 82](#);
 4. Not be disqualified from bidding on any public works contract under [RCW 39.06.010](#) or [39.12.065\(3\)](#);
 5. If bidding on a public works project subject to the apprenticeship utilization requirements in RCW 39.04.320, not have been found out of compliance by the Washington State Apprenticeship and Training Council for working apprentices out of ratio, without appropriate supervision, or outside their approved work processes as outlined in their standards of apprenticeship under Chapter 49.04 RCW for the one-year period immediately preceding the date of the bid solicitation; and
 6. Public Works and Prevailing Wage Training/Exemption. Bidders shall have received training on the requirements related to public works and prevailing wage under this chapter and chapter [39.12 RCW](#). The bidder must designate a person or persons to be trained on these requirements. The training must be provided by the department of labor and industries or by a training provider whose curriculum is approved by the department. The department, in consultation with the prevailing wage advisory committee, must determine the length of the training. Bidders that have completed three or more public works projects and have had a valid business license in Washington for three or more years are exempt from this subsection. The department of labor and industries must keep records of entities that have satisfied the training requirement or are exempt and make the records available on its website. Responsible parties may rely on the records made available by the department regarding satisfaction of the training requirement or exemption. <https://lni.wa.gov/licensing-permits/public-works-projects/contractors-employers/contractor-training>
 7. Within the three-year period immediately preceding the bid solicitation, not have been determined by a final a binding citation and notice of assessment issued by the department of labor and industries or through a civil judgment entered by a court of limited or general jurisdiction to have willfully violated, as defined in RCW 49.48.082, any provision of Chapters 49.46, 49.48, or 49.52 RCW. By signing the Bid Proposal Form, the bidder verifies under penalty of perjury, pursuant to RCW 9A.72.085. that the bidder is in compliance with this subsection

**WASHINGTON STATE PARK AND RECREATION COMMISSION
PUBLIC WORKS PROJECT**

8. **Supplemental Responsibility Criteria:** In addition to the mandatory Bidder responsibility, the Owner may adopt relevant supplemental criteria for determining Bidder responsibility applicable to a particular project which the Bidder must meet (RCW 39.04.350 (3)).
- a. If applicable, the Owner shall consider an overall accounting of the attached supplemental criteria for determining Bidder responsibility "DIVISION 00 SUPPLEMENTAL RESPONSIBILITY CRITERIA".
 - b. At least seven (7) days prior to the bid submittal deadline, a potential Bidder may request that the Owner modify the supplemental responsibility criteria. The Owner will evaluate the information submitted by the potential Bidder and respond before the bid submittal deadline. If the evaluation results in a change of the criteria, the Owner will issue an ADDENDA to the bidding documents identifying the new criteria. The Addendum will be posted as a public notice in the State Parks Public Opportunities-MRSC Rosters Bonfire Procurement Portal.
 - c. Upon the Owner's request, the apparent low Bidder must supply the requested responsibility information within two (2) business days of request by the Owner. Withholding information or failure to submit all the information requested within the time provided may render the bid non-responsive and the bid/Bidder may be rejected by Rejection Letter. The rejection is specific to this project and will have no effect on other or future projects.
 - d. The Owner will not execute a contract with any other Bidder until two (2) business days after the Bidder determined to be not responsible has received the rejection letter.

9.1 PROTEST PROCEDURES

A. GENERAL:

This protest process is a courtesy provided by the Owner and it is not governed by Washington's Administrative Procedures Act (APA), RCW 34.05, nor does it confer any additional rights above and beyond what the Bidder already enjoys as a taxpayer. The purpose of this process is to allow the Owner to correct evaluation process errors and problems before a contract is executed.

Only a Bidder may file a protest regarding this solicitation.

The Bidder must strictly adhere to the protest process as set forth herein, the failure of which may result in a summary determination that the protest is without merit without an opportunity to cure.

B. FORM AND CONTENT:

All protests must:

- Be in writing.
- The protest must state and clearly articulate the grounds for the protest with specific facts and complete statements of the action(s) being protested.
- A description of the relief or corrective action being requested should also be included.

**WASHINGTON STATE PARK AND RECREATION COMMISSION
PUBLIC WORKS PROJECT**

- All protests shall be addressed to the Procurement Coordinator.

C. CONTENT LIMITATIONS:

The Owner does not currently mandate any page limitation. However, the protest must be clearly articulated, succinct, organized, logical, and professional.

The Owner will reject protests that:

- fail to state and clearly articulate at least one of the three GROUNDS;
- contain rants, attacks, and/or disparaging or abusive remarks;
- include multiple attachments or references (document dumping, document overload); or,
- appear to require the reader piece together voluminous amounts of material to decipher the argument being made.

D. SUBMISSION OF PROTEST:

- All protests must be submitted within two (2) business days following the day of the release of the Bid Tabulation/Announcement of the Apparent Low bid or after the formal Rejection Letter is sent. For purposes of timing the day of the release of the Bid Tabulation or the day of the Rejection Letter is sent to the Bidder shall not count.
- Bidders must send all protests to: contracts@parks.wa.gov. See also Subject Line.
- SUBJECT LINE: Must include the bid's identification number, and "PROTEST" in the subject line. Failure by the Bidder to include this information in the subject line may result in Bidder's protest not being timely recognized.

E. GROUNDS WHICH MAY BE PROTESTED:

- Conflict of Interest on the part of Owner staff.
- Errors in computing the score.
- Non-compliance with procedures described in the procurement document.

Protests will be rejected as without merit if they do not clearly and convincingly meet one of the GROUNDS above and/or seems to address issues such as:

- An evaluator's professional judgment on the quality of a response, or
- The Owner's assessment of its own and/or other agencies' needs or requirements, or,
- Issues, concerns, objections, or requests for changes that were or could have been addressed prior to the bids due date deadline.

Protests that do not clearly and convincingly meet the requirements and standards described herein are without merit and may be rejected.

**WASHINGTON STATE PARK AND RECREATION COMMISSION
PUBLIC WORKS PROJECT**

F. MANAGER ASSIGNMENT AND REVIEW:

Upon receipt of a protest that meets the requirements described herein, a protest review will be held by the Owner. The Owner will assign a Manager. The Manager is responsible for reviewing and investigating the Bidder's written protest and may meet with Owner staff or the Owner program that was involved in the solicitation. The Manager may consider the record and all reasonably available facts and will issue a protest determination in writing within fifteen (15) business days from receipt of the protest. If additional time is needed, the Manager will notify the protesting party of the need for additional time within 15 business days from receipt of the protest.

In the event a protest may affect the interest of another Bidder that submitted a response, the Owner may reach out to that Bidder, may provide an unedited copy of the protest to that Bidder, and may invite that Bidder to submit its views and any relevant information on the protest to the Manager.

G. PROTEST DETERMINATION AND FINDINGS AND DISSEMINATION:

The Manager's protest determination may:

- Find the protest lacking in merit and reject the protest;
- Find only technical or harmless errors in the Owner's acquisition process and determine the Owner to be in substantial compliance and reject the protest; OR
- Find merit in the protest and provide THE OWNER options which may include:
 - Correcting the errors and re-evaluating all responses;
 - Canceling the solicitation and possibly for a new solicitation to take place; OR
 - Making other findings and determining other courses of action as appropriate.

If the Owner rejects the protest, the Owner will enter into a contract with the Apparent Successful Bidder no sooner than two (2) business days after issuance of the protest determination by email to the protesting party at the email address indicated on the party's bid documents. For the purposes of timing, the date the protest determination is sent to the protesting party shall not count.

Dissemination: The Owner will disseminate the decision to all interested Bidders via email/email attachment to the email address provided by the Bidder in the Bidder's bid response.

H. OWNER DECISION IS FINAL:

The Manager's protest determination constitutes the Owner's final decision regarding the protest. If the protesting party disagrees with the protest determination, the Bidder may seek judicial relief in the Washington Superior Court for Thurston County within two (2) business days of the issuance of the protest determination.

**WASHINGTON STATE PARK AND RECREATION COMMISSION
PUBLIC WORKS PROJECT**

I. STRICT COMPLIANCE

Strict compliance with these protest procedures is essential in furtherance of the public interest. Any aggrieved party that fails to comply strictly with these protest procedures is deemed, by such failure, to have waived and relinquished forever any right or claim with respect to alleged irregularities in connection with the solicitation or award of the Contract. No person or party may pursue any judicial or administrative proceedings challenging the solicitation or award of this Contract, without first exhausting the administrative procedures specified herein.

J. REPRESENTATION

An aggrieved party may participate personally or, if a corporation or other artificial person, by a duly authorized representative. Whether or not participating in person, an aggrieved party may be represented, at the party's own expense, by counsel.

K. COMPUTATION OF TIME

In computing any period of time prescribed by this procedure, the day of the act or event from which the designated period of time begins to run is not included. The last day of the period is included. The term "business day" does not include Sunday, Saturday, or Washington State recognized holiday.

L. ACKNOWLEDGEMENT

By submitting a bid in response to this solicitation, the Bidder acknowledges that it has reviewed and acquainted itself with the bid protest procedures herein and agrees to be bound by such procedures as a condition of submitting a bid.

10.1 EXECUTION OF CONTRACT

- A. The successful bidder will be required to execute the contract and furnish performance bond and insurance certificate satisfactory to the Owner within 15 days after receiving properly prepared contract documents from the Owner.

11.1 RECIPROCAL PREFERENCE FOR RESIDENT CONTRACTORS

- A. In accordance with RCW 39.04.380 the State of Washington is enforcing a Reciprocal Preference for Resident Contractors. Any public works bid received from a nonresident contractor from a state that provides an in-state percentage bidding preference, a comparable percentage disadvantage must be applied to the bid of that nonresident contractor.

A nonresident contractor from a state that provides a percentage bid preference means a contractor that:

- a) is from a state that provides a percentage bid preference to its resident contractors bidding on public works contracts.
- b) at the time of bidding on a public works project, does not have a physical office located in Washington.

The state of residence for a nonresident contractor is the state in which the contractor was incorporated or, if not a corporation, the state where the contractor's business entity was formed, and for an individual, the individual's state of residence.

**WASHINGTON STATE PARK AND RECREATION COMMISSION
PUBLIC WORKS PROJECT**

All nonresident contractors will be evaluated for out of state bidder preference. If the state of the nonresident contractor provides an in-state contractor preference, a comparable percentage disadvantage will be applied to their bid prior to contract award.

This section does not apply to public works procured pursuant to RCW 39.04.155, 39.04.280, or any other procurement exempt from competitive bidding.

- B. A Comparable Percentage Disadvantage (CPD) will be applied to the bid of that nonresident contractor. The CPD is the in-state contractor percent advantage provided by the contractor’s home state. For the purpose of determining the successful bidder, multiply the Nonresident Contractor bid amount by the CPD. The “bid amount” is be the total of the base bid and all accepted alternate bid items. The CPD is added to the Nonresident Contractor bid amount which equates to the Nonresident Disadvantage Total. The Nonresident Disadvantage Total is compared to the Washington contractor bid amounts. The bidder with the lowest total is the successful bidder. See example below.

Alaska Nonresident Contractor Bid Amount	\$100,000
Multiplied by the Alaska CPD	x 0.05
<hr/>	
Alaska CPD Total	\$ 5,000
Alaska Nonresident Contractor Bid Amount	\$100,000
Alaska CPD Total	\$ 5,000
<hr/>	
Nonresident Disadvantage Total	\$105,000*

* Note – If the Nonresident Disadvantage Total is lower than all other Washington contractor bid amounts, the Alaska Nonresident Contractor is the successful bidder and will be awarded a contract for the bid amount of \$100,000.

If the Nonresident Disadvantage Total is higher than a Washington contractor bid amount, the successful Washington bidder will be awarded a contract for the bid amount.

12.1 MINORITY AND WOMEN'S BUSINESS ENTERPRISE (MWBE) UTILIZATION

In accordance with the legislative findings and policies set forth in Chapter 39.19 RCW, the State of Washington encourages participation in contracts by MWBE firms certified by the Office of Minority and Women’s Business Enterprises (OMWBE). Participation may be either on a direct basis in response to this solicitation/invitation or as a subcontractor to a Bidder. However, unless required by federal statutes, regulations, grants, or contract terms referenced in the contract documents, no preference will be included in the evaluation of bids, no minimum level of MWBE participation is required as a condition for receiving an award, and bids will not be rejected or considered non-responsive on that basis. Any affirmative action requirements set forth in federal regulations or statutes included or referenced in the contract documents will apply.

A. VOLUNTARY MWBE GOALS

1. The following voluntary numerical MWBE participation goals have been established for this solicitation:

MBE 10% WBE 6%

**WASHINGTON STATE PARK AND RECREATION COMMISSION
PUBLIC WORKS PROJECT**

2. These goals are voluntary, but achievement of the goals is encouraged. Bidders may contact OMWBE at <http://omwbe.wa.gov/> to obtain information on certified firms.

B. REPORTING REQUIREMENTS

1. If any part of the contract, (including the supply of materials and equipment) is subcontracted using certified MWBE firms during completion of the work, then prior to final acceptance or completion of the contract or as otherwise indicated in the contract documents the Bidder shall submit a statement of participation indicating that MWBEs were used and the dollar value of their subcontracts.
2. The provisions of this section are not intended to replace or otherwise change the requirements of RCW 39.30.060. If said statute is applicable to this contract then the failure to comply with RCW 39.30.060 will still render a bid non-responsive.

C. RECORD KEEPING

1. The Bidder shall maintain, for at least three years after completion of this contract, relevant records and information necessary to document the level of utilization of MWBEs and other businesses as subcontractors and suppliers in this contract as well as any efforts the Bidder makes to increase the participation of MWBEs. The Bidder shall also maintain, for at least three years after completion of this contract, a record of all quotes, bids, estimates, or proposals submitted to the Bidder by all businesses seeking to participate as subcontractors or suppliers in this contract. The State shall have the right to inspect and copy such records. If this contract involves federal funds, Bidder shall comply with all record keeping requirements set forth in any federal rules, regulations, or statutes included or referenced in the contract documents

D. SUGGESTED EFFORTS TO INCREASE PARTICIPATION BY MWBEs

1. Bidders are encouraged to advertise opportunities for subcontractors or suppliers in a manner reasonably designed to provide MWBEs capable of performing the work with timely notice of such opportunities, and all advertisements shall include a provision encouraging participation by MWBE firms. Advertising may be done through general advertisement (e.g., newspapers, journals, etc.) or by soliciting bids directly from MWBEs.
2. Additional Voluntary Efforts. Bidders are encouraged to:
 - (a) Break down total requirements into smaller tasks or quantities, where economically feasible, in order to permit maximum participation by MWBEs and other small businesses.
 - (b) Provide interested MWBEs with adequate and timely information about plans, specifications, and requirements of the Contract.
 - (c) Establish delivery schedules, where the requirements of this contract permit, that encourage participation by MWBEs and other small businesses.
 - (d) Reduce bonding requirements where practicable.
 - (e) Utilize the services of available minority community organizations, minority

WASHINGTON STATE PARK AND RECREATION COMMISSION PUBLIC WORKS PROJECT

contractor groups, local minority assistance offices, and organizations that provide assistance in the recruitment and placement of MWBEs and other small businesses.

3. The actions described in this section should supplement efforts to provide information to all qualified firms, and nothing in this section is intended to prevent or discourage the Bidders from inviting proposals for participation from non-MWBE firms as well as MWBE firms.

E. NON-DISCRIMINATION

1. Bidders shall not create barriers to open and fair opportunities for all businesses including MWBEs to participate in all State contracts and to obtain or compete for contracts and subcontracts as sources of supplies, equipment, construction and services. In considering offers from and doing business with subcontractors and suppliers, the Bidder shall not discriminate on the basis of race, color, creed, religion, sex, age, nationality, marital status, or the presence of any mental or physical disability in an otherwise qualified disabled person.

F. SANCTIONS

1. Any violation of the mandatory requirements of this part of the contract shall be a material breach of contract for which the Bidder may be subject to a requirement of specific performance, or damages and sanctions provided by contract, by RCW 39.19.090, or by other applicable laws.

12.2 VETERAN-OWNED BUSINESS AND SMALL, MINI, AND MICRO BUSINESS UTILIZATION

The State of Washington encourages participation in all of its contracts by Veteran-owned businesses (defined in RCW 43.60A.010) and located at:

<http://www.dva.wa.gov/program/certified-veteran-and-servicemember-owned-businesses> and Small, Mini and Micro businesses (defined in RCW 39.26.010) which have registered in WEBS at <https://pr-webs-vendor.des.wa.gov/>.

1. The following voluntary numerical WDVA and Small Business participation goals have been established for this solicitation:

WDVA 5% Small Business 5%

2. These goals are voluntary, but achievement of the goals is encouraged. Bidders may search Washington Small Businesses registered in WEBS at:

<https://pr-webs-vendor.des.wa.gov/> and WA Veteran-owned Businesses at <https://www.dva.wa.gov/veterans-their-families/veteran-ownedbusinesses/vob-search> to obtain information on registered firms.

12.3 SUBCONTRACTOR PARTICIPATION MONITORING AND REPORTING

- A. Once a contract is awarded through the solicitation or proposal process, the awarded Prime Contractor is obligated to complete the vendor registration in Access Equity. Access Equity is a secure online vendor management system (B2GNow). Confidential information (Tax ID, etc.)

**WASHINGTON STATE PARK AND RECREATION COMMISSION
PUBLIC WORKS PROJECT**

will not be published. Prime Contractors that have previously registered with B2Gnow for any public entity, must verify the system has updated information. Contractors can access the system at:

<https://omwbe.diversitycompliance.com/> or through a direct link on the Office of Minority and Women’s Business Enterprises (OMWBE) website at: <https://omwbe.wa.gov/>.

- B. Each month during the contract, the Prime Contractor will report payments to ALL Subcontractors through the Access Equity system. This monthly reporting information includes total payment in dollars made to the Subcontractor, payment dates, and any additional information required to verify payment to Subcontractors. The Prime Contractor will enter this payment information into the Access Equity system, and the Subcontractors will verify this payment information in the system. Online training is available through the Access Equity/B2Gnow system. This requirement applies to both Prime Contractors and Subcontractors.

END OF INSTRUCTIONS TO BIDDERS

/ / / / /

NOTE: These Supplementary Instructions to Bidders and Conditions apply to FEDERAL-funded State Agency projects.

SUPPLEMENTAL INSTRUCTIONS TO BIDDERS: FEDERAL AND STATE COMPLIANCE FOR ALL FEDERALLY FUNDED AGREEMENTS

APPLICABILITY AND SCOPE

This document applies to all entities (hereinafter "Contracted Party") performing work, providing services, or supplying goods under an agreement with the State Agency (the "Agency") where the project is funded in whole or in part by Federal grants (e.g., FEMA, USFWS, DHS, EPA, DOE, DOD, DOC, HUD).

PRECEDENCE OF TERMS

Federal regulations (2 CFR 200) act as the mandatory minimum standard. In the event of a conflict between these instructions and the base contract, the more restrictive federal-mandated terms shall control.

PART I: THE UNIFORM GUIDANCE (2 CFR 200) - GENERAL PROVISIONS

1. GENERAL COMPLIANCE AND INCORPORATION

The Contracted Party must comply with all applicable provisions of Title 2 of the Code of Federal Regulations, Part 200. These regulations are deemed physically incorporated into the agreement. Per the 2025 updates, the Contracted Party is responsible for "Flow-Down" compliance to all subrecipients and subcontractors.

2. ADMINISTRATIVE AND LEGAL REMEDIES (2 CFR 200 APPENDIX II)

For contracts exceeding the Simplified Acquisition Threshold (\$350,000), the Agency reserves the right to exercise all administrative, contractual, or legal remedies in instances where the Contracted Party violates or breaches contract terms. This includes, but is not limited to:

- Withholding of payment until the breach is cured.
- Liquidated damages as specified in the Scope of Work.
- Debarment proceedings at the state level.

3. TERMINATION FOR CAUSE AND CONVENIENCE

For all contracts in excess of \$10,000, the following applies:

- Termination for Convenience: The Agency may terminate the agreement at any time by written notice if it is in the public interest. The Contracted Party shall be paid for

work satisfactorily completed up to the date of termination.

- Termination for Cause: The Agency may terminate the agreement for the Contracted Party's failure to perform. In such cases, the Agency may seek to recover the costs of completion from the Contracted Party.

4. COST PLUS PERCENTAGE PROHIBITED (2 CFR 200.324)

The "Cost Plus a Percentage of Cost" (CPPC) method of contracting is strictly prohibited. This includes using a flat percentage for mark-ups on change orders, materials, or subcontractors without a fixed-fee cap. Only fixed-fee, lump-sum, or unit-price arrangements are authorized.

PART II: FINANCIAL INTEGRITY, RECORDS, AND AUDITS

5. ACCESS TO RECORDS AND MONITORING (2 CFR 200.337)

The Agency, the Federal Awarding Agency, and the Comptroller General of the United States shall have the right of access to any documents, papers, or other records of the Contracted Party which are pertinent to the Federal award. This right lasts as long as the records are retained and includes the right to conduct on-site interviews with employees.

6. RECORD RETENTION (2 CFR 200.334)

Financial records and supporting documents must be retained for three (3) years from the date of the final expenditure report. If any litigation or audit is started before the expiration of the 3-year period, the records must be retained until all findings are resolved.

7. SYSTEM FOR AWARD MANAGEMENT (SAM) AND DEBARMENT

The Contracted Party must maintain an active Unique Entity Identifier (UEI) and registration in SAM.gov. The party certifies that it is not presently debarred or suspended. Verification will be performed by the Agency prior to execution and periodically throughout the contract life.

PART III: DOMESTIC PREFERENCE & MATERIAL PROCUREMENT

8. BUILD AMERICA, BUY AMERICA ACT (BABA) (2 CFR PART 184)

For all infrastructure projects, a domestic content procurement preference applies to all Federal funds.

- Iron and Steel: All manufacturing processes, from the initial melting stage through the application of coatings, must occur in the U.S.
- Manufactured Products: The product must be manufactured in the U.S., and the

cost of components produced in the U.S. must exceed 55% of the total cost of all components.

- Construction Materials: Non-ferrous metals, plastic/polymer-based products, glass, fiber optic cable, lumber, engineered wood, and drywall must be produced in the U.S.

9. PROHIBITION ON CERTAIN TELECOMMUNICATIONS (2 CFR 200.216)

The Contracted Party is prohibited from using Federal funds to procure or obtain equipment, services, or systems that use "covered telecommunications equipment or services" as a substantial or essential component of any system. This includes equipment produced by Huawei Technologies Company, ZTE Corporation, or their affiliates.

10. RECOVERED MATERIALS (2 CFR 200.323)

In the performance of this contract, the Contracted Party shall make maximum use of products containing recovered materials that are EPA-designated items unless the product cannot be acquired:

1. Competitively within a timeframe providing for compliance with the contract.
2. Meeting contract performance requirements.
3. At a reasonable price.

PART IV: LABOR, WAGES, AND CIVIL RIGHTS

11. DUAL COMPLIANCE PREVAILING WAGES (RCW 39.12 / DAVIS-BACON)

For Public Works projects, the Contracted Party shall pay the higher of the two rates between the Washington State Prevailing Wage and the Federal Davis-Bacon Wage for each classification.

- Consultants/Vendors: While Davis-Bacon typically applies to laborers and mechanics, Consultants must comply with RCW 39.12 if their services involve on-site physical "Work" or surveying.

12. CONTRACT WORK HOURS AND SAFETY STANDARDS (40 U.S.C. 3701-3708)

For contracts exceeding \$100,000, the Contracted Party must pay time-and-a-half (1.5x) for any hours worked over 40 in a workweek. Per Section 3704, no worker shall be required to work in surroundings that are unsanitary, hazardous, or dangerous.

13. EQUAL OPPORTUNITY AND TITLE VI

- Non-Discrimination: No person shall be excluded from participation in, be denied the benefits of, or be subjected to discrimination under any program or activity receiving

Federal financial assistance on the basis of race, color, or national origin.

- Limited English Proficiency (LEP): The Contracted Party must take reasonable steps to ensure meaningful access to their programs and activities for persons with limited English proficiency.

14. SMALL AND MINORITY BUSINESSES (2 CFR 200.321)

The Contracted Party must take all necessary affirmative steps to assure that minority businesses, women's business enterprises, and labor surplus area firms are used when subcontracts or material purchases are let.

PART V: SPECIAL PROJECT CONDITIONS & ENVIRONMENTAL LAWS

15. ENVIRONMENTAL REVIEW (NEPA/ESA)

No "ground-disturbing" activities or restoration work shall commence until the Agency issues a written Notice to Proceed. This notice is contingent upon the completion of Federal NEPA and Endangered Species Act (ESA) reviews.

16. CULTURAL RESOURCES AND INADVERTENT DISCOVERY

If archaeological or historic materials are encountered during performance, the Contracted Party must STOP WORK IMMEDIATELY in the vicinity and implement the Agency's Inadvertent Discovery Plan (IDP).

17. BYRD ANTI-LOBBYING AMENDMENT (31 U.S.C. 1352)

Contractors, Consultants, and Vendors who apply or bid for an award of \$100,000 or more must file the required certification that they have not used Federal funds to influence an officer or employee of any agency or a Member of Congress regarding the award.

PART VI: WASHINGTON STATE STATUTORY REQUIREMENTS (RCW)

18. WASHINGTON LAW AGAINST DISCRIMINATION (RCW 49.60)

The Contracted Party must comply with all provisions of the Washington Law Against Discrimination, which provides broader protections than federal law in several categories.

19. PUBLIC DISCLOSURE OF FUNDING

Any public-facing documents, signage, or media releases describing the Project must explicitly acknowledge the Federal funding source and the Agency.

20. BUILDING CODE AND ACCESSIBILITY (RCW 19.27 / 70.92)

Any design or construction work (Consultant or Contractor) must comply with the Washington State Building Code and the Barrier-Free Facilities Act for aged and disabled persons.

ACKNOWLEDGMENT OF OBLIGATIONS

By submitting a proposal or executing an agreement, the Contracted Party acknowledges that the United States and the State of Washington have the right to seek judicial enforcement of these obligations. Failure to comply may result in contract termination, repayment of funds, and debarment from future public contracts.

Twanoh State Park
Lagoon, Shoreline and Stream Restoration
Contract # SW-C2023A

<https://mrscrosters.bonfirehub.com/portal>

The Bidder will submit the Bid to State Parks Public Opportunities
MRSC Bonfire Procurement Portal



Bidder Compliance Form |

Contractor Information

Person Signing Bid	_____	Firm Name	_____
Title Person Signing	_____	Physical Address	_____
Contractor Registration #	_____	City, State, ZIP	_____
Taxpayer Identification #	_____	Phone #	_____
Washington UBI #	_____	Cellular Phone #	_____
WA ESD #	_____	Email Address	_____

The Bidder Compliance Form verifies compliance with State of Washington Public Works Bid Laws and associated Project Documents. It highlights key project components and ensures acknowledgment. Failure to acknowledge this form within the Bid Form, as directed, will render the bid non-responsive. Acknowledging the form does not alter the bidder's obligation to comply with all contract documents if awarded the project.

Bidder's Declaration

The Bidder declares that they have carefully examined the site of the proposed work, the Drawings, Specifications and all of the conditions affecting the work. Therefore, the Bidder proposes to provide all labor, equipment, materials, and permits and to perform all work as required by, and in strict accordance with the Contract Documents as shown on the bid proposal form.

Bid Acceptance and Owner Discretion

The Owner reserves the right to accept or reject all bids and to waive informalities. The Bidder will allow sixty (60) days from bid deadline date for acceptance of its bid by the Owner.

Registration and Required Licenses

The Bidder is a registered contractor in compliance with Chapter 18.27 RCW. If applicable, as the prime contractor, the Bidder self-performing plumbing work holds the required licensure under Chapter 18.106 RCW. Similarly, if self-performing elevator work, the Bidder holds the necessary license in accordance with Chapter 70.87 RCW. Additionally, if the Bidder is self-performing electrical work, they are properly licensed under Chapter 19.28 RCW.

Time for Completion

Bidder agrees to Substantially Complete the project, including accepted alternates, in accordance with the drawings and specifications from the date provided on the Notice to Proceed letter, within the following calendar days:

60

Final Completion of all Work, in accordance with the Contract Documents, shall be achieved within 30 calendar days after the date of Substantial Completion.

Liquidated Damages

It is agreed that liquidated damages shall be levied for each and every calendar day by which the completion of the work is delayed beyond the time fixed for completion or extension of the contract, in the following amount:

\$250.00

Twanoh State Park
Lagoon, Shoreline and Stream Restoration
Contract # SW-C2023A
<https://mrscrosters.bonfirehub.com/portal>



The Bidder will submit the Bid to State Parks Public Opportunities
MRSC Bonfire Procurement Portal

Bid Form

Unit prices and estimated quantities shall be used to determine the Base Bid

These prices shall also be used to adjust the Contract in the event there is an increase or decrease in the estimated quantities. All costs shall be “in place” costs and complete, **excluding Washington State Sales Tax**. In the event of an irregularity, the unit price prevails. The Owner reserves the right to make mathematical corrections of multiplication or addition errors on the bid form.

Trench Excavation Safety Provisions

If the contract contains any work which requires trenching exceeding a depth of four (4) feet, all costs for adequate trench safety systems shall be identified as a separate bid item in compliance with Chapter 39.04 RCW. The purpose of this provision is to ensure that the bidder agrees to comply with all relevant trench safety requirements of Chapter 49.17 RCW and WAC 296-155-650. This bid amount shall be considered part of the total base bid. **Include a lump sum dollar amount (even if the value is \$0.00) to be considered responsive to the bid solicitation.**

Wage Certification

The bidder certifies under penalty of perjury under the laws of the State of Washington that the foregoing is true and correct: within the three-year period immediately preceding the bid solicitation date, the bidder has not been a “willful” violator, as defined in RCW 49.48.082, of any provision of chapters 49.46, 49.48, or 49.52 RCW, as determined by a final and binding citation and notice of assessment issued by the Department of Labor and Industries or through a civil judgment entered by a court of limited or general jurisdiction.

Base Bid Items (Be sure to include unit prices)

Item No.	Description	Est Qty	Unit Type	Unit Price	Total Amount
1	Trench Excavation Safety Provisions	1	LS.		\$0.00
2	Mobilization and Demobilization	1	LS.		\$0.00
3	Site Preparation	1	LS.		\$0.00
4	Clearing	1	LS.		\$0.00
5	Remove and Dispose of Existing Footbridge	1	LS.		\$0.00
6	Temporary Erosion Sediment Control	1	LS.		\$0.00
7	Water Management	1	LS.		\$0.00
8	Remove Concrete Bulkhead	1	LS.		\$0.00
9	Excavate and Haul	1	LS.		\$0.00
10	Provide Footbridge	1	LS.		\$0.00
11	Softshore Armoring Installation	1	LS.		\$0.00
12	Plant Installation	1	LS.		\$0.00

Item No.	Description	Est Qty	Unit Type	Unit Price	Total Amount
Total Base Bid					\$0.00

Apprentice Utilization Requirements

The apprentice labor hours required for this project are 15% of the total labor hours. The undersigned agrees to utilize this level of apprentice participation. A monetary incentive of **\$1,000.00** will be paid to the contractor meeting the apprentice utilization requirement. A monetary penalty will be applied to the contractor failing to meet the utilization requirement and failing to demonstrate a Good Faith Effort. The penalty will be \$100.00 per percentage point not utilized. The cost value associated with meeting the apprentice utilization requirement is included in the Base Bid. This provision is intended to satisfy RCW 39.04.320(4)(b).

Receipt of Addenda

List all addenda received, separated by commas (e.g., "1, 2, 3, 4"). Do not list only the final number (e.g., "4"). If no addenda, type "N/A." Failure to follow this may render your bid non-responsive.

Bid Acknowledgment and Compliance Certification

By signing and returning this form, you acknowledge compliance with the bid requirements. Failure to sign and submit this form will result in the bid being considered non-responsive.

/s/ Signature of Authorized Official
 Typing your name can count as a signature.

Date

Twanoh State Park
Lagoon, Shoreline and Stream Restoration
Contract # SW-C2023A
<https://mrscrosters.bonfirehub.com/portal>



The Bidder will submit the Bid to State Parks Public Opportunities - MRSC Bonfire Procurement Portal

MWBE, WA Small Business, Veteran-Owned Business Utilization Certification

The bidder certifies good faith efforts to provide opportunities to MWBEs, Small Businesses, and Veteran-Owned Businesses. If awarded, the bidder commits to utilizing these firms or approved substitutes on the project. If no such firms will be used, enter "N.A." on the first line.

	Firm Name, Address	Federal I.D. #	Type of Work	Certificate Number	MBE%	WBE%	Small Business%	Veteran Business%
1								
2								
3								
4								
Totals					0.00%	0.00%	0.00%	0.00%

The bidder may add rows for additional MWBE/WA Small and Veteran-Owned Business Utilization Certifications.

Twanoh State Park
Lagoon, Shoreline and Stream Restoration
Contract # SW-C2023A
<https://mrscrosters.bonfirehub.com/portal>
The Bidder will submit the Bid to State Parks Public Opportunities
MRSC Bonfire Procurement Portal



Subcontractor Utilization List

Subcontractor Utilization List (If Applicable)

In compliance with the contract documents, the following subcontractor list is submitted:

SUBCONTRACTOR LISTING - RCW 39.30.060

If the base bid and the sum of the additive alternates is **ONE MILLION DOLLARS OR MORE**, the Bidder shall provide names of the subcontractors with whom the Bidder will **directly** subcontract for performance of the following work. If the Bidder intends to perform the work, the Bidder must enter its name for that category of work.

- A. Pursuant to RCW 39.30.060, the Bidder shall submit the names of subcontractors as follows:
- HVAC, Plumbing, and Electrical:** The names of subcontractors and proof of license for these trades (or the Bidder's own name and proof of license) must be submitted at the published bid submittal time.
 - Structural Steel and Rebar:** The names of subcontractors for these trades may be submitted at the published bid submittal time, but must be submitted no later than 48 hours after the published bid submittal time.
- B. List Subcontractors: The Bidder shall indicate on the Subcontractors List the names of the subcontractors with whom the Bidder, if awarded the contract, will directly subcontract for performance of the work of heating, ventilation, and air conditioning, plumbing as described in Chapter 18.106 RCW, electrical as described in Chapter 19.28 RCW, structural steel installation, and rebar installation.
- C. List Bidder if Bidder Performing Work: If the Bidder will self-perform the work in any of the five areas required, the Bidder shall name itself for the work on the Subcontractors List.
- D. Name Only One Firm for Each Category of Work: The Bidder shall not list more than one firm (subcontractor or Bidder) for each category of work identified, unless subcontractors vary with bid Alternatives or Additives, in which case the Bidder must indicate which firm will be used for which Alternate or Additive.
- E. Substitution of Subcontractors: Substitution of any listed subcontractor may only be according to the procedure and parameters set forth in RCW 39.30.060.
- F. Factors Relating to Non-Responsiveness: **Failure of the Bidder to submit the names and license numbers of such subcontractors or to name itself to perform such work or the naming of two or more firms (subcontractors or Bidder) to perform the same work, or failure to sign the form shall render the Bidder's bid non-responsive and, therefore, VOID.**
- G. The Subcontractor Utilization List is intended to discourage bid shopping, not to verify subcontractor qualifications. The Owner does not use the Subcontractor Utilization List as a tool to disqualify or qualify bidders.
- H. Applicable to Direct Subcontractors: The obligation under this section to identify proposed subcontractors for heating, ventilation and air conditioning, plumbing, electrical, structural steel installation, and rebar installation applies solely to subcontractors in these trades who will enter into a direct contractual relationship with the Bidder.

1 For HVAC, Plumbing, and Electrical

HVAC, Electrical, Plumbing: The requirement of this section to name the bidder's proposed heating, ventilation and air conditioning, plumbing and electrical subcontractors applies only to proposed heating, ventilation, and air conditioning, plumbing and electrical subcontractors who will contract directly with the bidder.

Errors in the proof of license may be corrected by the Bidder within 48 hours of submission.

Category of Work	Bidder MUST check one box for each Category of Work. If subcontracting the work, bidder must name the subcontractor
HVAC (Heating, Ventilation & Air Conditioning)	<input type="checkbox"/> Name of Subcontractor: _____ Sub License Number: _____ <input type="checkbox"/> Bidder will self-perform this work, or the project does not include this work.
Electrical	<input type="checkbox"/> Name of Subcontractor: _____ Sub License Number: _____ <input type="checkbox"/> Bidder will self-perform this work, or the project does not include this work.
Plumbing	<input type="checkbox"/> Name of Subcontractor: _____ Sub License Number: _____ <input type="checkbox"/> Bidder will self-perform this work, or the project does not include this work.

Bidder may attach a separate sheet for additional alternate bid subcontractors

2 For Structural Steel Installation and Rebar Installation

Structural Steel Installation and Rebar Installation: The requirement of this section to name the bidder's proposed names of the subcontractors with whom the bidder, if awarded, will subcontract for performance of the work of structural steel installation and rebar installation.

You may submit these now, or strictly within 48 hours after the bid submittal time, to contracts@parks.wa.gov.

Category of Work	Bidder MUST check one box for each Category of Work. If subcontracting the work, bidder must name the subcontractor
Structural Steel Installation	<input type="checkbox"/> Name of Subcontractor: _____ Sub License Number: _____ <input type="checkbox"/> Bidder will self-perform this work, or the project does not include this work.
Rebar Installation	<input type="checkbox"/> Name of Subcontractor: _____ Sub License Number: _____ <input type="checkbox"/> Bidder will self-perform this work, or the project does not include this work.

Bidder may attach a separate sheet for additional alternate bid subcontractors

Bidder Certification

By signing below, the Bidder certifies that the above subcontractors have been contacted and have agreed to perform the work if the contract is awarded.

/s/ Signature of Authorized Official **Date**
Typing your name can count as a signature.

Twanoh State Park
Lagoon, Shoreline and Stream Restoration
SW-C2023A

<https://mrscrosters.bonfirehub.com/portal>

The Bidder will submit the Bid Bond (if Applicable) to State Parks Public Opportunities

MRSC Bonfire Procurement Portal



Bid Bond Requirements

Bid Guarantee: See Instructions to Bidders 11.1 Bid Bond. No particular bid bond form is required. Failure of the Bidder to provide bid guarantee when required shall render the bid non-responsive.

Bid Bond Threshold

- 1 A bid bond is not required if the total bid amount, including all additive alternates, is \$35,000 or less.
- 2 For bids exceeding \$35,000, a bid bond of 5% of the total bid amount is mandatory.

Acceptable Forms

- 1 Acceptable forms of bid guarantee: A bid bond, and must be submitted as part of the bid response.
- 2 Scanned copies of the bid bond (e.g., PDF) are acceptable and should be included with the electronic bid submission

Submission Process

- 1 Include the bid bond in a single PDF file.
- 2 At the time of bid, the bidder must upload an electronic copy of the acceptable bid guarantee to the State Parks Opportunities via MRSC Portal Bonfire <https://mrscrosters.bonfirehub.com/portal>

Retention and Forfeiture

- 1 Bid bonds for the three lowest bidders will be retained for 30 days or until a contract is executed with the successful bidder.
- 2 All other bid bonds will be released within 15 days of the bid opening.
- 3 If the successful bidder fails to execute the contract or provide a performance bond within 15 days of receiving the contract forms, the bid bond may be forfeited as liquidated damages.

Bid Validity Period

- 1 Bidders must allow for a 60-day acceptance period from the bid opening date.

Important Reminder

- 1 Review all bid documents thoroughly to ensure compliance with submission requirements, including proper completion and inclusion of the bid bond when applicable.

For further details or clarification, refer to Section 11.1 of the "Instructions to Bidders" in the project manual. If you have questions, contact contracts@parks.wa.gov

Check the box to the left if the total bid, including all additive alternates, is \$35,000 or less, and include this statement with your bid response. No bid bond is required for bids at or below this amount. For bids exceeding \$35,000, a bid bond must be submitted instead. Failure to provide a required bid bond will render the bid non-responsive.

Twanoh State Park
Lagoon, Shoreline and Stream Restoration
Contract # SW-C2023A

<https://mrscrosters.bonfirehub.com/portal>

The Bidder will submit the Bid to State Parks Public Opportunities

MRSC Bonfire Procurement Portal



Federal Compliance Certification

Consolidated Federal Compliance Certification

I, the undersigned, as an authorized representative of the bidding entity, hereby certify and declare under penalty of perjury under the laws of Washington State and the United States that the following statements are true and correct: will render the bid non-responsive. Acknowledging the form does not alter the bidder's obligation to comply with all contract documents if awarded the project.

Section I: Non-Collusion and Ethics

The bidder has not, either directly or indirectly, entered into any agreement, participated in any collusion, or otherwise taken any action in restraint of free competitive bidding in connection with this project.

The bidder shall comply with the Copeland "Anti-Kickback" Act (40 U.S.C. 3145), ensuring that no person employed in the construction or repair of this public work has been induced to give up any part of their rightful compensation.

Section II: Federal Eligibility and Debarment

SAM.gov Status: Neither the bidder nor its principals are presently debarred, suspended, proposed for debarment, or declared ineligible for the award of contracts by any Federal department or agency.

The bidder agrees to verify the eligibility of all subcontractors via the System for Award Management (SAM.gov) prior to entering into any lower-tier covered transactions

Section III: Anti-Lobbying (31 U.S.C. 1352)

No Federal appropriated funds have been paid or will be paid to any person for influencing or attempting to influence an officer or employee of any agency or a Member of Congress in connection with this award.

If the contract value exceeds \$100,000 and any non-federal funds have been used for lobbying, the bidder has completed and submitted Standard Form-LLL ("Disclosure of Lobbying Activities").

Section IV: Domestic Preference (Build America, Buy America)

The bidder certifies that all iron, steel, manufactured products, and construction materials used in this project will be produced in the United States in accordance with 2 CFR Part 184 and the Bipartisan Infrastructure Law.

For manufactured products, the bidder certifies that the cost of domestic components exceeds the federally mandated threshold (currently 55%) of the total cost of all components.

Section V: Labor Standards and Dual Prevailing Wages

The bidder acknowledges that this project is subject to both Davis-Bacon (Federal) and RCW 39.12 (Washington State) prevailing wage requirements.

The bidder agrees to pay the higher of the two rates (State vs. Federal) for each labor classification and to maintain and submit certified payroll records as required.

Section VI: Environmental and Cultural Compliance

The bidder understands that physical construction activities shall not commence until the Owner issues a written Notice to Proceed following the completion of all required federal and state environmental reviews.

The bidder agrees to stop work immediately if inadvertent archaeological or historical materials are encountered and to follow all applicable cultural resource protection protocols and Inadvertent Discovery Plans (IDP).

Section VII: Socioeconomics Steps (2 CFR 200.321)

The bidder certifies they will take all necessary affirmative steps to ensure that minority businesses, women's business enterprises, and labor surplus area firms are used whenever subcontracts are let.

This includes placing qualified firms on solicitation lists and dividing requirements into smaller tasks to permit maximum participation.

Bidder Signature and Authorization

/s/ Signature of Authorized Official

Typing your name can count as a signature.

Date

**TWANOHO STATE PARK
LAGOON, SHORELINE AND STREAM RESTORATION**

The following list of major items of construction has been included for Bidder's convenience in preparing a bid proposal. Exclusion of items from this summary does not indicate exclusion from project. For lump sum items, the bidder is cautioned that the drawings are the only source for measurement of project quantities, and drawings have been detailed for this purpose. In preparing a bid proposal, Bidder should note apparent discrepancies between the list below and the drawings and consult with Engineer for verification.

BASE BID ITEMS

BID ITEM	DESCRIPTION	ESTIMATED QUANTITY	PAYMENT
1.	TRENCH EXCAVATION SAFETY PROVISIONS See instructions on Bid Proposal Form.	L.S.	PER LUMP SUM
2.	MOBILIZATION AND DEMOBILIZATION Includes all work associated with preconstruction expenses and the costs of preparatory work.	L.S.	PER LUMP SUM
3.	SITE PREPARATION Includes all work to establish and mark clearing limits and post temporary signage. Includes all materials, labor and machinery necessary to install a temporary chain link fence (~1,492 linear feet with 20-foot entry gate) as shown on the Plans.	L.S.	PER LUMP SUM
4.	CLEARING Includes salvaging, stockpiling, and maintaining (watering) saltwater vegetation for reuse. Also includes re-planting salvaged saltwater vegetation around the fringe of the new lagoon (~1500 square feet). Provide temporary fencing to allow plants to re-establish (~160 lineal feet). Includes all labor to remove and dispose of trees (7) as shown on Plans. Trees shall become property of contractor and hauled off site to a location provided by contractor.	L.S.	PER LUMP SUM
5.	REMOVE AND DISPOSE OF EXISTING FOOTBRIDGE Includes all work to remove and dispose of pedestrian footbridge and abutments as shown on the Plans.	L.S.	PER LUMP SUM
6.	TEMPORARY EROSION SEDIMENT CONTROL Includes all materials, labor and machinery to install jute mat erosion control fabric (~7,150 SF) along shoreline restoration reach and seed and straw all disturbed areas as, install silt fence (~500 linear feet) for temporary erosion sediment control during construction as shown on the Plans. Also includes installing temporary erosion sediment control fencing (~750 linear feet).	L.S.	PER LUMP SUM

**TWANOH STATE PARK
LAGOON, SHORELINE AND STREAM RESTORATION**

7. WATER MANAGEMENT L.S. PER LUMP SUM

Includes all materials, labor and machinery to install water control features to remove or prevent water from entering or leaving (untreated) construction areas as shown on the Plans.

8. REMOVE CONCRETE BULKHEAD L.S. PER LUMP SUM

Includes all work to remove and dispose of an ~400-foot long concrete bulkhead (~162 tons) at a recycling facility. Also includes stockpiling, replacing, grading and compacting sand and gravel material back into excavation void created from concrete bulkhead removal (~ 200 cubic yards).

9. EXCAVATE AND HAUL L.S. PER LUMP SUM

Lagoon: Includes all work to excavate lagoon and tidal channel (~969 cubic yards), redistribute material for re-grading (~173 cubic yards), and to haul excess sand and gravel material to an off-site location provided by contractor (~796 cubic yards).

Shoreline and Stream: Includes all work to excavate riprap and sand & gravel material (~8,900 CY) for softshore armoring installation and for floodplain expansion and stream restoration. Includes stockpiling excavated sand & gravel material (~2,900 CY) for reuse to backfill softshore armoring installation. Excess or unsuitable non-contaminated material (~1,869 tons of riprap and ~4,950 CY of native beach sand and gravel) become property of Contractor and shall be hauled to an offsite location provided by Contractor.

10. PROVIDE FOOTBRIDGE L.S. PER LUMP SUM

Includes purchase of footbridge and all materials, labor, and machinery to install footbridge, footbridge abutment, access ramp, railings and backfill as depicted on the Plans.

11. SOFTSHORE ARMORING INSTALLATION L.S. PER LUMP SUM

Includes all labor and materials (Contractor to purchase LWD) to install LWD (~107 pieces) along shoreline and backfill with stockpiled sand & gravel (~2,900 CY) as shown on Plans. Also includes excavation, installation and backfilling of LWD within the floodplain and stream channel (~48 pieces) as shown on the Plans. Includes all materials, labor and machinery to install coir lifts for bioengineered shoreline and streambanks (~3,519 linear feet of coir lifts) and pedestrian beach-access pathways and ADA pads (3) as shown on Plans. Also includes installing interpretive pad and walkway (~720 square feet) as shown on the Plans. Includes all labor and imported gravel materials (to be purchased by Contractor) to install deformable berm (~624 CY) along shoreline as shown on the Plans.

12. PLANT INSTALLATION L.S. PER LUMP SUM

Includes all labor and materials to plant bioengineered streambanks (~3,519 linear feet) as shown on the Plans.

END OF SECTION

TWANOH STATE PARK
LAGOON, SHORELINE AND STREAM RESTORATION

**SUPPLEMENTAL BIDDER RESPONSIBILITY CRITERIA
WITH INCLUSION PLAN AND APPRENTICESHIP REQUIREMENTS**

Low Responsible Bidder

It is the intent of the Agency to award a contract to the lowest responsive and responsible Bidder. In determining the Bidder's responsibility, the Agency shall consider an overall accounting of the items listed below. Potential Bidders may request the Agency modify the Bidder responsibility criteria. The request must be in writing and submitted at least 7 days prior to the bid opening.

The apparent low bidder shall submit the required information within **two (2)** business days of receiving request from the Agency. This request may be made in the form of a telephone call or email message. The required information shall be provided on the referenced forms bound herein. Electronic copies may be made available upon request. Failure to submit such information to the satisfaction of the Agency within the time provided may render the Bidder as not responsible.

1.1 REQUIRED INFORMATION/CRITERIA

- A. For the purposes of the Supplemental Bidder Responsibility evaluation process, the scope of this project generally involves:
- Removing a concrete bulkhead, expanding an existing saltwater lagoon, constructing a tidal channel, re-planting salvaged native vegetation around the fringe of the new lagoon.
 - Removing existing riprap and several trees along the shoreline and streambanks; naturalizing the shoreline by installing large woody debris, bioengineered softshore armoring and a deformable gravel berm; performing work within Twanoh Creek that includes expanding the floodplain, installing clusters of large woody debris within the stream and floodplain, removing and replacing a pedestrian bridge and abutments, and installing bioengineered streambanks.
- B. Experience Of Contractor On Projects Of Similar Size And Complexity: Contractor is required to have successfully completed at least **three (3)** projects of similar type, size and complexity to this project, each with a contract amount of at least **\$500,000**, within the last **seven (7)** years.
- C. List of Completed Projects (Use Form 1, Contractor Experience Detail): Provide a list of all the construction contracts **\$500,000** and above your firm has completed within the past **three (3)** years, giving the name of the project; name, address, and phone numbers of Owner and architect representatives; final contract amount; date of completion; and percentage of the cost of the work performed with your firm's own forces. This information will be used for reference reviews.

2.1 EXPERIENCE OF KEY PERSONNEL

- A. Experience of Project Manager (Use Form 2, Résumé of Key Personnel for Proposed Contract): Submit resume and references for the proposed Project Manager. This person shall have managed, as lead project manager, a minimum of **three (3)** projects of similar type, size and complexity to this project, and successfully completed those projects within the last **ten (10)** years.
- B. Experience of Superintendent (Use Form 2, Résumé of Key Personnel for Proposed Contract): Submit resume and references for the proposed project Superintendent. This person shall have performed as the lead Superintendent for a minimum of **three**

TWANOH STATE PARK
LAGOON, SHORELINE AND STREAM RESTORATION

(3) projects of similar type, size and complexity to this project, and successfully completed those projects within the last **ten (10)** years.

3.1 DIVERSE BUSINESS INCLUSION PLAN (USE FORM 3)

- A. Washington state goals are: Minority Business Enterprise (MBE) 10%, Women's Business Enterprise (WBE) 6%, WA Small Business 5% and WA Veterans 5%. The apparent low bidder is required to submit a Diverse Businesses Inclusion Plan for all projects with a Maximum Allowable Construction Cost (MACC) over \$1M.

The Diverse Business Inclusion plan shall include the apparent low bidder's anticipated participation goals, the subcontractors anticipated to be used on this project, a list of diverse businesses near the project, the project's diverse expert, and past performance using diverse businesses.

4.1 APPRENTICESHIP (USE FORMS 1 & 4)

- A. For each public works project with an apprenticeship utilization goal that was completed by the Bidder within three (3) years of the bid submittal date for this project, the Bidder shall submit the following:

- A list of such projects;
- The owner and contact information for the owner's representative;
- The apprenticeship utilization percentage goal for the project;
- The actual utilization percentage by the Bidder; and
- An explanation of any extenuating circumstances that contributed to the Bidder not meeting the goals.

(Use Form 4 for projects not listed on Form 1)

The Agency may contact previous owners to validate the information provided by the Bidder and shall consider whether the goals were mandatory or voluntary, and the validity of any explanation of extenuating circumstances.

5.1 REFERENCES FROM OWNERS AND ARCHITECTS FOR PREVIOUS PROJECTS (AGENCY USES FORM 5, REFERENCE EVALUATION QUESTIONNAIRE)

- A. The Agency may check references by contacting owners and architects of the bidder's previous projects regarding the bidder's performance and that of key staff. A reference score sheet will be utilized and the rating shall be satisfactory or better on a five-category scale with "satisfactory" at mid-scale.

6.1 OVERALL SCORING (FORM 6, RESPONSIBILITY CRITERIA EVALUATION SCORE SHEET)

- A. The Agency will use this form to complete and document the overall evaluation process.

END OF SECTION

**TWANOH STATE PARK
LAGOON, SHORELINE AND STREAM RESTORATION**

**Supplemental Bidder Responsibility
Form 1 - Contractor Experience Detail**

Contractor Information:		
Contractor Legal Name:		Contact Person and their Position/Title:
Project Superintendent:		Project Manager:
Physical Address (Physical and Mailing Addresses are the Same <input type="checkbox"/>):		Mailing Address:
Telephone:	Cell Phone:	Email Address:

Project Information: Is this project relevant to the proposed project? Yes <input type="checkbox"/> No <input type="checkbox"/>	
Project:	Location:
Project Description:	As Prime: <input type="checkbox"/> As Sub: <input type="checkbox"/>
Original Contract Amount: \$ Final Contract Amount: \$	Original Contract Days: Final Contract Days:

Owner Information:	
Owner's Business Name:	Contact Person and their Position/Title:
Mailing Address :	Telephone: Email Address:

Architect/Engineering Information:	
Owner's Business Name:	Contact Person and their Position/Title:
Mailing Address :	Telephone: Email Address:

**TWANOH STATE PARK
LAGOON, SHORELINE AND STREAM RESTORATION**

**Supplemental Bidder Responsibility
Form 2 - Resume of Key Personnel**

Name:	Role in this Contract:	Years Experience	
		Total	With Current Firm
Firm Name and Location (City and State):			
Training/Education/Specialization:			
Years of Experience in the Proposed Role:			

RELEVANT PROJECTS			
Project Title:		Year Completed	
Project Owner:			
Brief Description (Brief scope, size, cost, etc.) and specific role:		Check if project performed with current firm. <input type="checkbox"/> If performed with different firm list the firm name	
Reference Name & Contact Information:			
Project Owner:		Project Architect:	
Name:		Name:	
Phone:		Phone:	
E-mail		E-mail:	

RELEVANT PROJECTS			
Project Title:		Year Completed	
Project Owner:			
Brief Description (Brief scope, size, cost, etc.) and specific role:		Check if project performed with current firm. <input type="checkbox"/> If performed with different firm list the firm name	
Reference Name & Contact Information:			
Project Owner:		Project Architect:	
Name:		Name:	
Phone:		Phone:	
E-mail		E-mail:	

RELEVANT PROJECTS			
Project Title:		Year Completed	
Project Owner:			
Brief Description (Brief scope, size, cost, etc.) and specific role:		Check if project performed with current firm. <input type="checkbox"/> If performed with different firm list the firm Name	
Reference Name & Contact Information:			
Project Owner:		Project Architect:	
Name:		Name:	
Phone:		Phone:	
E-mail		E-mail:	

**TWANOH STATE PARK
LAGOON, SHORELINE AND STREAM RESTORATION**

RELEVANT PROJECTS		
Project Title:	Year Completed	
Project Owner:		
Brief Description (Brief scope, size, cost, etc.) and specific role:	Check if project performed with current firm. <input type="checkbox"/> If performed with different firm list the firm Name	
Reference Name & Contact Information:		
Project Owner:		Project Architect:
Name:		Name:
Phone:		Phone:
E-mail		E-mail:

RELEVANT PROJECTS		
Project Title:	Year Completed	
Project Owner:		
Brief Description (Brief scope, size, cost, etc.) and specific role:	Check if project performed with current firm. <input type="checkbox"/> If performed with different firm list the firm Name	
Reference Name & Contact Information:		
Project Owner:		Project Architect:
Name:		Name:
Phone:		Phone:
E-mail		E-mail:

RELEVANT PROJECTS		
Project Title:	Year Completed	
Project Owner:		
Brief Description (Brief scope, size, cost, etc.) and specific role:	Check if project performed with current firm. <input type="checkbox"/> If performed with different firm list the firm Name	
Reference Name & Contact Information:		
Project Owner:		Project Architect:
Name:		Name:
Phone:		Phone:
E-mail		E-mail:

**TWANOH STATE PARK
LAGOON, SHORELINE AND STREAM RESTORATION**

**Supplemental Bidder Responsibility
Form 3 - Prime Contractor Diverse Business Inclusion Plan**

Prime Contractor Name: _____

For the purposes of this form, Washington State-certified diverse businesses are defined as follows:

- *Minority Business Enterprise (MBE), Women’s Business Enterprise (WBE),* or combination of the two. Certified by the Office of Minority and Women’s Business Enterprises (OMWBE): <http://omwbe.wa.gov/>
- *Veteran-owned Business.* Certified by the Department of Veteran’s Affairs (DVA): <http://dva.wa.gov/>
- *Small Business* (includes Mini and Micro businesses). Certified through the Washington Electronic Business Solution (WEBS): <https://fortress.wa.gov/ga/webs/home.html>

Anticipated Certified Diverse Business Participation Goals

Subcontracting means direct performance of commercially useful work through subcontracting as part of the proposed project team. Of the total contract work, what are the diverse business participation goals proposed for subcontracting on your team? Please only include the above-listed Washington State certification types in your “Contractor-defined Anticipated Percent of Contract Amount (Goals)” estimate. Zero percent (0%) is not a goal.

Anticipated Certified Diverse Business Participation Goals	Washington State Goals	Contractor-defined Anticipated Percent of Contract Amount (Goals)
Minority-owned business (MBE)	10%	%
Women-owned business (WBE)	6%	%
Veteran-owned business (DVA)	5%	%
Small business	5%	%

Subcontracting Team

List the names of the diverse businesses you anticipate using on this project. Generally describe the work you expect the diverse business to perform and identify the percent of total contract value intended for each diverse business. Please include the above-listed Washington State certification types. *If necessary, add more rows below.*

Name of Diverse Business	Specify Diverse Business Certification (circle one or more)	Describe Trade or Task	Anticipated Percent of Contract Amount
	MBE, WBE, DVA, Small		%
	MBE, WBE, DVA, Small		%
	MBE, WBE, DVA, Small		%
	MBE, WBE, DVA, Small		%
	MBE, WBE, DVA, Small		%

Attach a list of diverse businesses near the project location to this form:

1. Go to <https://omwbe.wa.gov/directory-certified-firms>
2. Click on “OMWBE DIRECTORY”
3. Click on “Search Certified Firm Directory”
4. Select MBE, MWBE, SBE, and WBE certifications.
5. Enter a City, Zip Code, or County near the project site address and then press “Search” at the bottom of the page. If you do not have many results, please expand your search to include nearby locations.
6. Print and attach the results to this form with your submittal

Diverse Expert:

Diverse Expert responsibilities would typically include, but are not limited to:

- Outreach to qualified diverse businesses.
- Submit and discuss updates on a regular basis to the state project manager regarding Diverse Business utilization and progress.
- Ongoing outreach to diverse businesses for required contract work, including any changes in scope.
- Assist diverse businesses with successful contract performance.

TWANOH STATE PARK LAGOON, SHORELINE AND STREAM RESTORATION

A qualified Diverse Expert brings knowledge of the identity, capabilities and capacities of diverse business subcontractors and suppliers; experience recruiting and working with diverse businesses for construction; and assisting diverse businesses to develop working relationships with contractors.

Identify the person within your team to manage your diverse inclusion responsibility.

Diverse Expert Name:

Diverse Expert Contact Information:

Diverse Expert Firm (if another firm is managing participation):

Past Performance

Please select **five (5) of your projects** with Washington State-certified diverse business participation (MBE, WBE, DVA, and/or Small/Mini/Micro) and list them below **for the last five (5) years**. If you do not have any projects that tracked or reported diverse business participation, you may leave this section blank. In that case, please attach an additional sheet with explanation.

You may have projects with diverse business participation for an organization or entity that required *different* diverse business categories (including self-certification). If so, please attach a sheet with the same column data and information, but include percentages for the categories that were tracked during the project.

Contract Name	Contracting Agency or Entity	Contract Amount	Year	Percent of Contract Amount	
				Minority-owned business:	%
				Women-owned business:	%
				Veteran-owned business:	%
				Small/mini/micro business:	%
Contract Name	Contracting Agency or Entity	Contract Amount	Year	Percent of Contract Amount	
		\$		Minority-owned business:	%
				Women-owned business:	%
				Veteran-owned business:	%
				Small/mini/micro business:	%
Contract Name	Contracting Agency or Entity	Contract Amount	Year	Percent of Contract Amount	
		\$		Minority-owned business:	%
				Women-owned business:	%
				Veteran-owned business:	%
				Small/mini/micro business:	%
Contract Name	Contracting Agency or Entity	Contract Amount	Year	Percent of Contract Amount	
		\$		Minority-owned business:	%
				Women-owned business:	%
				Veteran-owned business:	%
				Small/mini/micro business:	%
Contract Name	Contracting Agency or Entity	Contract Amount	Year	Percent of Contract Amount	
		\$		Minority-owned business:	%
				Women-owned business:	%
				Veteran-owned business:	%
				Small/mini/micro business:	%

**TWANOH STATE PARK
LAGOON, SHORELINE AND STREAM RESTORATION**

**Supplemental Bidder Responsibility
Form 4 – Apprenticeship Utilization**

Contractor Information:		
Contractor Legal Name:		Contact Person and their Position/Title:
Project Superintendent:		Project Manager:
Physical Address (Physical and Mailing Addresses are the Same <input type="checkbox"/>):		Mailing Address:
Telephone:	Cell Phone:	Email Address:

Project Information: Is this project relevant to the proposed project? Yes <input type="checkbox"/> No <input type="checkbox"/>	
Project:	Location:
Project Description:	As Prime: <input type="checkbox"/> As Sub: <input type="checkbox"/>
Original Contract Amount: \$ Final Contract Amount: \$	Original Contract Days: Final Contract Days:

Owner Information:	
Owner's Business Name:	Contact Person and their Position/Title:
Mailing Address :	Telephone: Email Address:

Architect/Engineering Information:	
Owner's Business Name:	Contact Person and their Position/Title:
Mailing Address :	Telephone: Email Address:

1. Did this project require Apprenticeship Participation? Yes No (If NO, stop here)
2. If yes, what was the Apprenticeship percentage? _____ %
3. What was the actual percentage achieved? _____ %
4. Was the apprenticeship requirement met? Yes No

**TWANOH STATE PARK
LAGOON, SHORELINE AND STREAM RESTORATION**

5. If NO to question 4, explain Why.

**TWANOH STATE PARK
LAGOON, SHORELINE AND STREAM RESTORATION**

**Supplemental Bidder Responsibility
Form 5 - Reference Evaluation Questionnaire**

Evaluated Firm :
Project Manager:
Superintendent:
Evaluated Project Name:

- Prime
 Subcontractor

Approx. Start Date	Approx. End Date	Approx. Final Project Cost

PERFORMANCE EVALUATION

Rating Criteria - Rate on a scale of 1 to 5

- **5 = Superior** based on performance (would hire this firm/individual again)
- **4 = More than Satisfactory**
- **3 = Satisfactory** based on performance (would hire this firm/individual again)
- **2 = Less than Satisfactory**
- **1= Totally Unsatisfactory** based on performance (would never hire the firm/individual again)

	Criteria	Rating		
		Company	PM	Super
1	Ability to meet client's expectations			
2	Quality of workmanship			
3	Ability to manage project costs and minimize change orders			
4	Ability to maintain project schedule			
5	Ability to manage subcontractors			
6	Professionalism, leadership and communication in issues management (RFI, shop drawing submittal, timely resolution of issues/questions)			
7	Ability to follow the owner's rules, regulations, and requirements (housekeeping, safety, etc.)			
8	Ability to manage closeout process (Prompt submittal of punch list, warranty, as-builts, operation manuals, tax clearances, etc.)			
9	Comfort level in hiring firm or individual again based on performance			
Total Score				
Average Score				

Evaluator Information	
Name of Evaluator:	Title:
Firm/Company Name:	
Firm Address:	
Phone:	Email:

Form 6 – Supplemental Responsibility Criteria Evaluation Score Sheet

Project Location _____
 Project Name _____
 Contract Number _____
 Project Representative _____

1. Experience of Contractor - On projects of similar size & complexity (Form 1)	Pass or Fail
--	--------------

2. Experience of Key Personnel (Form 2)	
Superintendent	Pass or Fail
Project Manager	Pass or Fail
Other(s) if specified in Division 00	Pass or Fail

3. Diverse Business Inclusion Plan (Form 3) <i>(Applies only to projects with Diverse Business Plan Inclusion requirements; i.e. MACC over \$1M)</i>	Pass, Fail, or N/A
---	--------------------

4. Contractor Compliance with Apprenticeship Requirements - Requirements were met or if not, a good faith effort was demonstrated (Forms 1 & 4) <i>Applies only to projects with apprenticeship participation requirements; i.e. MACC over \$1M</i>	Not Scored
--	------------

5. References from Previous Projects (Form 5) Evaluate contractor's references information and using the rating numbers: 1 = NOT Satisfactory (requires a written comment below) 2 = Less THAN Satisfactory 3 = Satisfactory 4 = More THAN Satisfactory 5 = Superior	Rating Score 1-5 (3 is Satisfactory)
Company	
Project Manager	
Superintendent	
Total Score:	
Average score (divide total score by number of ratings)	

In determining the bidder responsibility, an overall accounting of the ratings shall be made. A score of "Pass" is required for categories 1 - 4 and an average score of 3.0 or higher is required to meet the minimum Supplemental Bidder Responsibility requirements.

Comments _____

Determination Responsible
 Not Responsible (Preliminary Determination)

Evaluated by _____ Date _____
 State Parks Project Representative

Signature _____

GENERAL CONDITIONS FOR CONSTRUCTION AT WASHINGTON STATE PARKS

<u>Part</u>	<u>Page</u>	<u>Part</u>	<u>Page</u>
PART 1 GENERAL PROVISIONS		5.15 Tests and Inspection	20
1.01 Definitions	2	5.16 Correction of Nonconforming Work	21
1.02 Order of Precedence	3	5.17 Clean Up	22
1.03 Execution and Intent	4	5.18 Access to Work	22
PART 2 INSURANCE AND BONDS		5.19 Other Contracts	22
2.01 Contractor's Liability Insurance	4	5.20 Subcontractors and Suppliers	22
2.02 Coverage Limits	5	5.21 Warranty of Construction	24
2.03 Insurance Coverage Certificates	6	5.22 Indemnification	24
2.04 Payment and Performance Bonds	6	5.23 American with Disabilities Act (ADA) Compliance	24
2.05 Alternative Surety	6	PART 6 PAYMENTS AND COMPLETION	
2.06 Builder's Risk	6	6.01 Contract Sum	25
PART 3 TIME AND SCHEDULE		6.02 Schedule of Values	25
3.01 Progress and Completion	7	6.03 Application for Payment	26
3.02 Construction Schedule	7	6.04 Progress Payments	26
3.03 Owner's Right to Suspend the Work for Convenience	8	6.05 Payments Withheld	27
3.04 Owner's Right to Stop the Work for Cause	8	6.06 Retainage and Bond Claim Rights	27
3.05 Delay	8	6.07 Substantial Completion	27
3.06 Notice to Owner of Labor Disputes	9	6.08 Prior Occupancy	27
3.07 Damages for Failure to Achieve Timely Completion	9	6.09 Final Completion, Acceptance, and Payment	28
PART 4 SPECIFICATIONS, DRAWINGS, AND OTHER DOCUMENTS		PART 7 CHANGES	
4.01 Discrepancies and Contract Document Review	10	7.01 Changes in the Work	28
4.02 Project Record	10	7.02 Change in the Contract Sum	29
4.03 Submittals	10	7.03 Change in the Contract Time	34
4.04 Organization of Specifications	11	PART 8 CLAIMS AND DISPUTE RESOLUTION	
4.05 Ownership and Use of Drawings, Specifications, and Other Documents	11	8.01 Claims Procedure	35
PART 5 PERFORMANCE		8.02 Arbitration	36
5.01 Contractor Control and Supervision	12	8.03 Claims Audits	37
5.02 Permits, Fees and Notices	13	PART 9 TERMINATION OF THE WORK	
5.03 Patents and Royalties	13	9.01 Termination by Owner for Cause	38
5.04 Prevailing Wages	13	9.02 Termination by Owner for Convenience	39
5.05 Hours of Labor	14	PART 10 MISCELLANEOUS PROVISIONS	
5.06 Nondiscrimination	14	10.01 Governing Law	39
5.07 Safety Precautions	15	10.02 Successors and Assigns	39
5.08 Operations, Material Handling, and Storage Areas	17	10.03 Meaning of Words	39
5.09 Prior Notice of Excavation	17	10.04 Rights and Remedies	40
5.10 Unforeseen Physical Conditions	18	10.05 Contractor Registration	40
5.11 Protection of Existing Structures, Equipment, Vegetation, Utilities, and Improvements	18	10.06 Time Computations	40
5.12 Layout of Work	19	10.07 Records Retention	40
5.13 Material and Equipment	19	10.08 Third-Party Agreements	40
5.14 Availability and Use of Utility Services	20	10.09 Antitrust Assignment	40
		10.10 Minority & Women's Business Enterprises (MWBE) Participation	40
		10.11 Minimum Levels of Apprenticeship Participation	41
		10.12 Headings and Captions	42
		10.13 Subcontractor Payments Reporting Requirements	42

GENERAL CONDITIONS FOR CONSTRUCTION AT WASHINGTON STATE PARKS

PART 1 - GENERAL PROVISIONS

1.01 DEFINITIONS

- A. "Application for Payment" means a written request submitted by Contractor to A/E for payment of Work completed in accordance with the Contract Documents and approved Schedule of Values, supported by such substantiating data as Owner or A/E may require.
- B. "Architect," "Engineer," or "A/E" shall mean that person designated by the State Parks and Recreation Commission to be in charge of the work covered by this contract.
- C. "Change Order" means a written instrument signed by Owner and Contractor stating their agreement upon all of the following: (1) a change in the Work; (2) the amount of the adjustment in the Contract Sum, if any, and (3) the extent of the adjustment in the Contract Time, if any.
- D. "Claim" means Contractor's exclusive remedy for resolving disputes with Owner regarding the terms of a Change Order or a request for equitable adjustment, as more fully set forth in part 8.
- E. "Contract Award Amount" is the sum of the Base Bid and any accepted Alternates.
- F. "Contract Documents" means the Advertisement for Bids, Instructions for Bidders, completed Form of Proposal, General Conditions, Modifications to the General Conditions, Supplemental Conditions, Public Works Contract, other Special Forms, Drawings and Specifications, and all addenda and modifications thereof.
- G. "Contract Sum" is the total amount payable by Owner to Contractor for performance of the Work in accordance with the Contract Documents, including all taxes imposed by law and properly chargeable to the Work, except Washington State sales tax.
- H. "Contract Time" is the number of calendar days allotted in the Contract Documents for achieving Substantial Completion of the Work.
- I. "Contractor" means the person or entity who has agreed with Owner to perform the Work in accordance with the Contract Documents.
- J. "Drawings" are the graphic and pictorial portions of the Contract Documents showing the design, location, and dimensions of the Work, and may include plans, elevations, sections, details, schedules, and diagrams.
- K. "Final Acceptance" means the written acceptance issued to Contractor by Owner after Contractor has completed the requirements of the Contract Documents, as more fully set forth in Section 6.09 B.
- L. "Final Completion" means that the Work is fully and finally completed in accordance with the Contract Documents, as more fully set forth in Section 6.09 A.
- M. "Force Majeure" means those acts entitling Contractor to request an equitable adjustment in the Contract Time, as more fully set forth in paragraph 3.05 A.
- N. "Notice" means a written notice which has been delivered in person to the individual or a member of the firm or entity or to an officer of the corporation for which it was intended or, if delivered or sent by registered or certified mail, to the last business address known to the party giving notice.
- O. "Notice to Proceed" means a notice from Owner to Contractor that defines the date on which the Contract Time begins to run.
- P. "Owner" shall mean the Washington State Parks and Recreation Commission and its authorized representative with the authority to enter into, administer and/or terminate contracts and make related determinations and findings.
- Q. "Person" means a corporation, partnership, business association of any kind, trust, company, or individual.

GENERAL CONDITIONS FOR CONSTRUCTION AT WASHINGTON STATE PARKS

- R. "Prior Occupancy" means Owner's use of all or parts of the Project before Substantial Completion, as more fully set forth in Section 6.08 A.
- S. "Progress Schedule" means a schedule of the Work, in a form satisfactory to Owner, as further set forth in section 3.02.
- T. "Project" means the total construction of which the Work performed in accordance with the Contract Documents may be the whole or a part and which may include construction by Owner or by separate contractors.
- U. "Project Manual" means the volume usually assembled for the Work which may include the bidding requirements, sample forms, and other Contract Documents.
- V. "Project Record" means the separate set of Drawings and Specifications as further set forth in paragraph 4.02A.
- W. "Schedule of Values" means a written breakdown allocating the total Contract Sum to each principle category of Work, in such detail as requested by Owner.
- X. "Specifications" are that portion of the Contract Documents consisting of the written requirements for materials, equipment, construction systems, standards, and workmanship for the Work, and performance of related services.
- Y. "Subcontract" means a contract entered into by Subcontractor for the purpose of obtaining supplies, materials, equipment, or services of any kind for or in connection with the Work.
- Z. "Subcontractor" means any person, other than Contractor, who agrees to furnish or furnishes any supplies, materials, equipment, or services of any kind in connection with the Work.
- AA. "Substantial Completion" means that stage in the progress of the Work where Owner has full and unrestricted use and benefit of the facilities for the purposes intended, as more fully set forth in section 6.07.
- AB. "Work" means the construction and services required by the Contract Documents, and includes, but is not limited to, labor, materials, supplies, equipment, services, permits, and the manufacture and fabrication of components, performed, furnished, or provided in accordance with the Contract Documents.

1.02 ORDER OF PRECEDENCE

Any conflict or inconsistency in the Contract Documents shall be resolved by giving the documents precedence in the following order.

1. Signed Public Works Contract, including any Change Orders, and any Special Forms.
2. Supplemental Conditions.
3. General Conditions.
4. Addenda
5. Specifications--provisions in Division 1 shall take precedence over provisions of any other Division.
6. Drawings--in case of conflict within the Drawings, large scale drawings shall take precedence over small scale drawings.
7. Signed and Completed Form of Proposal.
8. Instructions to Bidders.
9. Advertisement for Bids.

GENERAL CONDITIONS FOR CONSTRUCTION AT WASHINGTON STATE PARKS

1.03 EXECUTION AND INTENT

Contractor makes the following representations to Owner:

1. The Contract Sum is reasonable compensation for the Work and the Contract Time is adequate for the performance of the Work, as represented by the Contract Documents;
2. Contractor has carefully reviewed the Contract Documents, visited and examined the Project site, become familiar with the local conditions in which the Work is to be performed, and satisfied itself as to the nature, location, character, quality and quantity of the Work, the labor, materials, equipment, goods, supplies, work, services and other items to be furnished and all other requirements of the Contract Documents, as well as the surface and subsurface conditions and other matters that may be encountered at the Project site or affect performance of the Work or the cost or difficulty thereof;
3. Contractor is financially solvent, able to pay its debts as they mature, and possesses sufficient working capital to complete the Work and perform Contractor's obligations required by the Contract Documents; and
4. Contractor is able to furnish the plant, tools, materials, supplies, equipment and labor required to complete the Work and perform the obligations required by the Contract Documents and has sufficient experience and competence to do so.

PART 2 - INSURANCE AND BONDS

2.01 CONTRACTOR'S LIABILITY INSURANCE

Prior to commencement of the Work, Contractor shall obtain all the insurance required by the Contract Documents and provide evidence satisfactory to Owner that such insurance has been procured. Review of the Contractor's insurance by Owner shall not relieve or decrease the liability of Contractor. Companies writing the insurance to be obtained by this part shall be licensed to do business under Chapter 48 RCW or comply with the Surplus Lines Law of the State of Washington. Contractor shall include in its bid the cost of all insurance and bond costs required to complete the base bid work and accepted alternates. Insurance carriers providing insurance in accordance with the Contract Documents shall be acceptable to Owner, and its A. M. Best rating shall be indicated on the insurance certificates.

- A. Contractor shall maintain the following insurance coverage during the Work and for one year after Final Acceptance. Contractor shall also maintain the following insurance coverage during the performance of any corrective Work required by section 5.16.
 1. Commercial General Liability (CGL) on an Occurrence Form:
 - a. Completed operations/products liability;
 - b. Explosion, collapse, and underground; and
 - c. Employer's liability coverage.
 2. Automobile liability
- B. Contractor shall comply with the Washington State Industrial Insurance Act and, if applicable, the Federal Longshoremen's and Harbor Workers' Act and the Jones Act.
- C. All insurance coverages shall protect against claims for damages for personal and bodily injury or death, as well as claims for property damage, which may arise from operations in connection with the Work whether such operations are by Contractor or any Subcontractor.
- D. All insurance coverages shall be endorsed to include Owner as an additional named insured for Work performed in accordance with the Contract Documents, and all insurance certificates shall evidence the Owner as an additional insured.

GENERAL CONDITIONS FOR CONSTRUCTION AT WASHINGTON STATE PARKS

2.02 COVERAGE LIMITS INSURANCE COVERAGE CERTIFICATES

A. Insurance Coverage Certificates

The Contractor shall furnish acceptable proof of insurance coverage on the State of Washington Certificate of Insurance form SF500A dated 07/02/92 or an acceptable ACORD form.

B. Required Coverages

1. For a contract less than \$100,000.00, the coverage required is:

a. Public Liability Insurance – The Contractor shall at all times during the term of this contract, at its cost and expense, carry and maintain general public liability insurance, including contractual liability, against claims for bodily injury, personal injury, death or property damage occurring or arising out of services provided under this contract. This insurance shall cover claims caused by any act, omission, or negligence of the Contractor or its officers, agents, representatives, assigns or servants. The limits of liability insurance, which may be increased as deemed necessary by the contracting parties, shall be:

Each Occurrence	\$1,000,000.00
General Aggregate Limits (other than products – commercial operations)	\$1,000,000.00
Products – Commercial Operations Limit	\$1,000,000.00
Personal and Advertising Injury Limit	\$1,000,000.00
Fire Damage Limit (any one fire)	\$50,000.00
Medical Expense Limit (any one person)	\$5,000.00

b. If the contract is for underground utility work, then the Contractor shall provide proof of insurance for that above in the form of Explosion, Collapse and Underground (XCU) coverage.

c. Employers Liability on an occurrence basis in an amount not less than \$1,000,000.00 per occurrence.

2. For contracts over \$100,000.00 but less than \$5,000,000.00 the contractor shall obtain the coverage limits as listed for contracts below \$100,000.00 and General Aggregate and Products – Commercial Operations Limit of not less than \$2,000,000.00.

3. Coverage for Comprehensive General Bodily Injury Liability Insurance for a contract over \$5,000,000.00 is:

Each Occurrence	\$2,500,000.00
General Aggregate Limits (other than products – commercial operations)	\$5,000,000.00
Products – Commercial Operations limit	\$5,000,000.00
Personal and Advertising Injury Limit	\$2,500,000.00
Fire Damage Limit (any one fire)	\$50,000.00
Medical Expense Limit (any one Person)	\$5,000.00

4. For all Contracts – Automobile Liability: in the event that services delivered pursuant to this contract involve the use of vehicles or the transportation of clients, automobile liability insurance shall be required. If Contractor-owned personal vehicles are used, a Business Automobile Policy covering at a minimum Code 2 “owned autos only” must be secured. If Contractor employee’s vehicles are used, the Contractor must also include under the Business Automobile Policy Code 9, coverage for non-owned autos. The minimum limits for automobile liability is: \$1,000,000.00 per occurrence, using a combined single limit for bodily injury and property damage.

5. For Contracts for Hazardous Substance Removal (Asbestos Abatement, PCB Abatement, etc.)

a. In addition to providing insurance coverage for the project as outlined above, the Contractor shall provide Environmental Impairment Liability insurance for the hazardous substance removal as follows:

<u>EACH OCCURRENCE</u>	<u>AGGREGATE</u>
\$500,000.00	\$1,000,000.00

or \$1,000,000.00 each occurrence/aggregate bodily injury and property damage combined single limit.

GENERAL CONDITIONS FOR CONSTRUCTION AT WASHINGTON STATE PARKS

- 1) Insurance certificate must state that the insurer is covering hazardous substance removal.
- 2) Should this insurance be secured on a "claims made" basis, the coverage must be continuously maintained for one year following the project's "final completion" through official completion of the project, plus one year following.

For Contracts where hazardous substance removal is a subcomponent of contracted work, the general contractor shall provide to the Owner a certificate of insurance for coverage as defined in 5a. above. The State of Washington must be listed as an additional insured. This certificate of insurance must be provided to the Owner prior to commencing work.

2.03 INSURANCE COVERAGE CERTIFICATES

- A. Prior to commencement of the Work, Contractor shall furnish to Owner a completed certificate of insurance coverage.
- B. All insurance certificates shall name Owner's Project number and Project title.
- C. All insurance certificates shall specifically require 45 (forty-five) days prior notice to Owner of cancellation or any material change, except 30 (thirty) days for surplus line insurance.

2.04 PAYMENT AND PERFORMANCE BONDS

AIA Payment and Performance Bonds, form A312, or equivalent, is required by the Owner for the work of this contract. The forms shall be obtained from the Contractor's bonding company. The Payment Bond shall cover payment to laborers and mechanics, including payments to Employee Benefit Funds, and payments to subcontractors, material suppliers, and persons who shall supply such person or persons, or subcontractors with materials and supplies.

2.05 ALTERNATIVE SURETY

Contractor shall promptly furnish alternative security required to protect Owner and persons supplying labor or materials required by the Contract Documents if:

- A. Owner has a reasonable objection to the surety; or
- B. Any surety fails to furnish reports on its financial condition if requested by Owner.

2.06 BUILDER'S RISK

- A. Contractor shall purchase and maintain property insurance in the amount of the Contract Sum including all Change Orders for the Work on a replacement cost basis until Substantial Completion. The insurance shall cover the interest of Owner, Contractor, and any Subcontractors, as their interests may appear. For projects not involving New Building Construction, 'Installation Floater' is an acceptable substitute for the Builder's Risk Insurance.
- B. Contractor property insurance shall be placed on an "all risk" basis and insure against the perils of fire and extended coverage and physical loss or damage including theft, vandalism, malicious mischief, collapse, false work, temporary buildings, debris removal including demolition occasioned by enforcement of any applicable legal requirements, and shall cover reasonable compensation for A/E's services and expenses required as a result of an insured loss.
- C. Owner and Contractor waive all subrogation rights against each other, any Subcontractors, A/E, A/E's subconsultants, separate contractors described in section 5.20, if any, and any of their subcontractors, for damages caused by fire or other perils to the extent covered by property insurance obtained pursuant to this section or other property insurance applicable to the Work, except such rights as they have to proceeds of such insurance held by Owner as fiduciary. The policies shall provide such waivers of subrogation by endorsement or otherwise. A waiver of subrogation shall be effective to a person or entity even though that person or entity would otherwise have a duty of indemnification, contractual or otherwise, did not pay the insurance premium directly or indirectly, and whether or not the person or entity had an insurable interest in the property damaged.

GENERAL CONDITIONS FOR CONSTRUCTION AT WASHINGTON STATE PARKS

PART 3 - TIME AND SCHEDULE

3.01 PROGRESS AND COMPLETION

- A. Contractor shall diligently prosecute the Work, with adequate forces, achieve Substantial Completion within the Contract Time, and achieve Final Completion within 30 (thirty) calendar days thereafter, unless otherwise noted in Division 1 of the specifications.
- B. The Contractor shall notify the Engineer at least two (2) weekdays in advance if work is to be performed on a Saturday, Sunday, or legal holiday. No excavation work will be allowed on Saturdays, Sundays, or legal holidays unless specifically authorized by the Engineer.

3.02 CONSTRUCTION SCHEDULE

- A. Unless otherwise provided in Division 1, Contractor shall, within 14 (fourteen) calendar days after issuance of the Notice to Proceed, submit a preliminary Progress Schedule. The Progress Schedule shall show the sequence in which Contractor proposes to perform the Work, and the dates on which Contractor plans to start and finish major portions of the Work, including dates for shop drawings and other submittals, and for acquiring materials and equipment.
- B. The Progress Schedule shall be in the form of a Critical Path Method (CPM) logic network or, with the approval of the Owner, a bar chart schedule may be submitted. The scheduling of construction is the responsibility of the Contractor and is included in the contract to assure adequate planning and execution of the work. The schedule will be used to evaluate progress of the work for payment based on the Schedule of Values. The schedule shall show the Contractor's planned order and interdependence of activities, and sequence of work. As a minimum the schedule shall include:
 - 1. Date of Notice to Proceed;
 - 2. Activities (resources, durations, individual responsible for activity, early starts, late starts, early finishes, late finishes, etc.);
 - 3. Utility Shutdowns;
 - 4. Interrelationships and dependence of activities;
 - 5. Planned vs. actual status for each activity;
 - 6. Substantial completion;
 - 7. Punch list;
 - 8. Final inspection;
 - 9. Final completion, and
 - 10. Float time

The Schedule Duration shall be based on the Contract Time of Completion listed on the Bid Proposal form. The Owner shall not be obligated to accept any Early Completion Schedule suggested by the Contractor. The Contract Time for Completion shall establish the Schedule Completion Date.

If the Contractor feels that the work can be completed in less than the Specified Contract Time, then the Surplus Time shall be considered Project Float. This Float time shall be shown on the Project Schedule. It shall be available to accommodate changes in the work and unforeseen conditions.

Neither the Contractor nor the Owner have exclusive right to this Float Time. It belongs to the project.

- C. Owner shall return comments on the preliminary Progress Schedule to Contractor within 14 (fourteen) days of receipt. Review by Owner of Contractor's schedule does not constitute an approval or acceptance of Contractor's construction means, methods, or sequencing, or its ability to complete the Work within the Contract Time. Contractor shall revise and resubmit its schedule, as necessary. Owner may withhold a portion of progress payments until a Progress Schedule has been submitted which meets the requirements of this section.
- D. Contractor shall utilize and comply with the Progress Schedule. On a monthly basis, or as otherwise directed by Owner, Contractor shall submit an updated Progress Schedule at its own expense to Owner indicating actual progress. If, in the opinion of Owner, Contractor is not in conformance with the Progress Schedule for reasons other than acts of Force Majeure as identified in section 3.05, Contractor shall take

GENERAL CONDITIONS FOR CONSTRUCTION AT WASHINGTON STATE PARKS

such steps as are necessary to bring the actual completion dates of its work activities into conformance with the Progress Schedule, or revise the Progress Schedule to reconcile with the actual progress of the Work.

- E. Contractor shall promptly notify Owner in writing of any actual or anticipated event which is delaying or could delay achievement of any milestone or performance of any critical path activity of the Work. Contractor shall indicate the expected duration of the delay, the anticipated effect of the delay on the Progress Schedule, and the action being or to be taken to correct the problem. Provision of such notice does not relieve Contractor of its obligation to complete the Work within the Contract Time.

3.03 OWNER'S RIGHT TO SUSPEND THE WORK FOR CONVENIENCE

- A. Owner may, at its sole discretion, order Contractor, in writing, to suspend all or any part of the Work for up to 90 (ninety) days, or for such longer period as mutually agreed.
- B. Upon receipt of a written notice suspending the Work, Contractor shall immediately comply with its terms and take all reasonable steps to minimize the incurrence of cost of performance directly attributable to such suspension. Within a period up to 90 (ninety) days after the notice is delivered to Contractor, or within any extension of that period to which the parties shall have agreed, Owner shall either:
 - 1. Cancel the written notice suspending the Work; or
 - 2. Terminate the Work covered by the notice as provided in the termination provisions as more fully set forth in Part 9.
- C. If a written notice suspending the Work is cancelled or the period of the notice or any extension thereof expires, Contractor shall resume Work.
- D. Contractor shall be entitled to an equitable adjustment in the Contract Time, or Contract Sum, or both, for increases in the time or cost of performance directly attributable to such suspension, provided Contractor complies with all requirements set forth in Part 7.

3.04 OWNER'S RIGHT TO STOP THE WORK FOR CAUSE

- A. If Contractor fails or refuses to perform its obligations in accordance with the Contract Documents, Owner may order Contractor, in writing, to stop the Work, or any portion thereof, until satisfactory corrective action has been taken.
- B. Contractor shall not be entitled to an equitable adjustment in the Contract Time or Contract Sum for any increased cost or time of performance attributable to Contractor's failure or refusal to perform or from any reasonable remedial action taken by Owner based upon such failure.

3.05 DELAY

- A. Any delay in or failure of performance by Owner or Contractor, other than the payment of money, shall not constitute a default hereunder if and to the extent the cause for such delay or failure of performance was unforeseeable and beyond the control of the party ("Force Majeure"). Acts of Force Majeure include, but are not limited to:
 - 1. Acts of God or the public enemy;
 - 2. Acts or omissions of any government entity;
 - 3. Fire or other casualty for which Contractor is not responsible;
 - 4. Quarantine or epidemic;
 - 5. Strike or defensive lockout;
 - 6. Unusually severe weather, in excess of weather conditions which could not have been reasonably anticipated; and

GENERAL CONDITIONS FOR CONSTRUCTION AT WASHINGTON STATE PARKS

7. Unusual delay in receipt of supplies or products which were ordered and expedited and for which no substitute reasonably acceptable to Owner was available.
- B. Contractor shall be entitled to an equitable adjustment in the Contract Time for changes in the time of performance directly attributable to an act of Force Majeure, provided it makes a request for equitable adjustment according to section 7.03. Contractor shall not be entitled to an adjustment in the Contract Sum resulting from an act of Force Majeure.
- C. Contractor shall be entitled to an equitable adjustment in Contract Time, and may be entitled to an equitable adjustment in Contract Sum, if the cost or time of Contractor's performance is changed due to the fault or negligence of Owner, provided the Contractor makes a request according to sections 7.02 and 7.03.
- D. Contractor shall not be entitled to an adjustment in Contract Time or in the Contract Sum for any delay or failure of performance to the extent such delay or failure was caused by Contractor or anyone for whose acts Contractor is responsible.
- E. To the extent any delay or failure of performance was concurrently caused by the Owner and Contractor, Contractor shall be entitled to an adjustment in the Contract Time for that portion of the delay or failure of performance that was concurrently caused, provided it makes a request for equitable adjustment according to section 7.03, but shall not be entitled to an adjustment in Contract Sum.
- F. Contractor shall make all reasonable efforts to prevent and mitigate the effects of any delay, whether occasioned by an act of Force Majeure or otherwise.
- G. The Owner has acquired ownership and/or easement of lands for the construction, as indicated on the drawings, without cost to the Contractor. The Contractor understands and agrees that, should it appear at any time that the Owner has not acquired title to all of the right-of-ways and lands necessary for the performance of the work under the provisions of this contract, and that if any delay in the performance of said work occasioned by the failure of the Owner, its officers, or employees to acquire a title of any of said lands or right-of-way, such failure shall extend the contract completion date the number of days equal to the period of such delay. The Contractor waives any and all claims for damages against the Owner which the Contractor may sustain by reason of this delay in the work.

3.06 NOTICE TO OWNER OF LABOR DISPUTES

- A. If Contractor has knowledge that any actual or potential labor dispute is delaying or threatens to delay timely performance in accordance with the Contract Documents, Contractor shall immediately give notice, including all relevant information, to Owner.
- B. Contractor agrees to insert a provision in its Subcontracts and to require insertion in all sub-subcontracts, that in the event timely performance of any such contract is delayed or threatened by delay by any actual or potential labor dispute, the Subcontractor or Sub-subcontractor shall immediately notify the next higher tier Subcontractor or Contractor, as the case may be, of all relevant information concerning the dispute.

3.07 DAMAGES FOR FAILURE TO ACHIEVE TIMELY COMPLETION

- A. Liquidated Damages
 1. Timely performance and completion of the Work is essential to Owner and time limits stated in the Contract Documents are of the essence. Owner will incur serious and substantial damages if Substantial Completion of the Work does not occur within the Contract Time. However, it would be difficult if not impossible to determine the exact amount of such damages. Consequently, provisions for liquidated damages are included in the Contract Documents.
 2. The liquidated damage amounts set forth in the Contract Documents will be assessed not as a penalty, but as liquidated damages for breach of the Contract Documents. This amount is fixed and agreed upon by and between the Contractor and Owner because of the impracticability and extreme difficulty of fixing and ascertaining the actual damages the Owner would in such event sustain. This amount shall be construed as the actual amount of damages sustained by the Owner, and may be retained by the Owner and deducted from periodic payments to the Contractor.

GENERAL CONDITIONS FOR CONSTRUCTION AT WASHINGTON STATE PARKS

3. Assessment of liquidated damages shall not release Contractor from any further obligations or liabilities pursuant to the Contract Documents.

B. Actual Damages

Actual damages will be assessed for failure to achieve Final Completion within the time provided. Actual damages will be calculated on the basis of direct architectural, administrative, and other related costs attributable to the Project from the date when Final Completion should have been achieved, based on the date Substantial Completion is actually achieved, to the date Final Completion is actually achieved. Owner may offset these costs against any payment due Contractor.

PART 4 - SPECIFICATIONS, DRAWINGS, AND OTHER DOCUMENTS

4.01 DISCREPANCIES AND CONTRACT DOCUMENT REVIEW

- A. The intent of the Specifications and Drawings is to describe a complete Project to be constructed in accordance with the Contract Documents. Contractor shall furnish all labor, materials, equipment, tools, transportation, permits, and supplies, and perform the Work required in accordance with the Drawings, Specifications, and other provisions of the Contract Documents.
- B. The Contract Documents are complementary. What is required by one part of the Contract Documents shall be binding as if required by all. Anything mentioned in the Specifications and not shown on the Drawings, or shown on the Drawings and not mentioned in the Specifications, shall be of like effect as if shown or mentioned in both.
- C. Contractor shall carefully study and compare the Contract Documents with each other and with information furnished by Owner. If, during the performance of the Work, Contractor finds a conflict, error, inconsistency, or omission in the Contract Documents, it shall promptly and before proceeding with the Work affected thereby, report such conflict, error, inconsistency, or omission to A/E in writing.
- D. Contractor shall do no Work without applicable Drawings, Specifications, or written modifications, or Shop Drawings where required, unless instructed to do so in writing by Owner. If Contractor performs any construction activity, and it knows or reasonably should have known that any of the Contract Documents contain a conflict, error, inconsistency, or omission, Contractor shall be responsible for the performance and shall bear the cost for its correction.
- E. Contractor shall provide any work or materials the provision of which is clearly implied and is within the scope of the Contract Documents even if the Contract Documents do not mention them specifically.
- F. Questions regarding interpretation of the requirements of the Contract Documents shall be referred to the A/E.

4.02 PROJECT RECORD

- A. Contractor shall legibly mark in ink on a separate set of the Drawings and Specifications all actual construction, including depths of foundations, horizontal and vertical locations of internal and underground utilities and appurtenances referenced to permanent visible and accessible surface improvements, field changes of dimensions and details, actual suppliers, manufacturers and trade names, models of installed equipment, and Change Order Proposals (COP). This separate set of Drawings and Specifications shall be the "Project Record."
- B. The Project Record shall be maintained on the project site throughout the construction and shall be clearly labeled "PROJECT RECORD". The Project Record shall be updated at least weekly noting all changes and shall be available to Owner at all times.
- C. Contractor shall submit the completed and finalized Project Record to A/E prior to Final Acceptance.

4.03 SUBMITTALS

- A. "Submittals" means documents and other information required to be submitted to A/E by Contractor pursuant to the Contract Documents, showing in detail: the proposed fabrication and assembly of structural

GENERAL CONDITIONS FOR CONSTRUCTION AT WASHINGTON STATE PARKS

elements; and the installation (i.e. form, fit, and attachment details) of materials and equipment. Submittals include, but are not limited to, drawings, diagrams, layouts, schematics, descriptive literature, illustrations, schedules, performance and test data, samples, and similar materials furnished by Contractor to explain in detail specific portions of the Work required by the Contract Documents. For materials and equipment to be incorporated into the Work, Contractor submittal shall include the name of the manufacturer, the model number, and other information concerning the performance, capacity, nature, and rating of the item. When directed, Contractor shall submit all samples at its own expense. Owner may duplicate, use, and disclose Submittals provided in accordance with the Contract Documents.

- B. Contractor shall coordinate all Shop Drawings, and review them for accuracy, completeness, and compliance with the Contract Documents and shall indicate its approval thereon as evidence of such coordination and review. Where required by law, Shop Drawings shall be stamped by an appropriate professional licensed by the state of Washington. Shop Drawings submitted to A/E without evidence of Contractor's approval shall be returned for resubmission. Contractor shall review, approve, and submit Shop Drawings with reasonable promptness and in such sequence as to cause no delay in the Work or in the activities of Owner or separate contractors. Contractor's submittal schedule shall allow a reasonable time for A/E review. A/E will review, approve, or take other appropriate action on the Shop Drawings. Contractor shall perform no portion of the Work requiring submittal and review of Shop Drawings until the respective submittal has been reviewed and the A/E has approved or taken other appropriate action. Owner and A/E shall respond to Shop Drawing submittals with reasonable promptness. Any Work by Contractor shall be in accordance with reviewed Shop Drawings. Submittals made by Contractor which are not required by the Contract Documents may be returned without action.
- C. Approval, or other appropriate action with regard to Submittals, by Owner or A/E shall not relieve Contractor of responsibility for any errors or omissions in such Submittals, nor from responsibility for compliance with the requirements of the Contract Documents. Unless specified in the Contract Documents, review by Owner or A/E shall not constitute an approval of the safety precautions employed by Contractor during construction, or constitute an approval of Contractor's means or methods of construction. If Contractor fails to obtain approval before installation and the item or work is subsequently rejected, Contractor shall be responsible for all costs of correction.
- D. If Shop Drawings show variations from the requirements of the Contract Documents, Contractor shall describe such variations in writing, separate from the Shop Drawings, at the time it submits the Shop Drawings containing such variations. If A/E approves any such variation, an appropriate Change Order will be issued. If the variation is minor and does not involve an adjustment in the Contract Sum or Contract Time, a Change Order need not be issued; however, the modification shall be recorded upon the Project Record.
- E. Unless otherwise provided in Division I, Contractor shall submit to A/E for approval 5 (five) copies of all Submittals. Unless otherwise indicated, 3 (three) sets of all Submittals shall be retained by A/E and 2 (two) sets shall be returned to Contractor.

4.04 ORGANIZATION OF SPECIFICATIONS

Specifications are prepared in sections which conform generally with trade practices. These sections are for Owner and Contractor convenience and shall not control Contractor in dividing the Work among the Subcontractors or in establishing the extent of the Work to be performed by any trade.

4.05 OWNERSHIP AND USE OF DRAWINGS, SPECIFICATIONS, AND OTHER DOCUMENTS

- A. The Drawings, Specifications, and other documents prepared by A/E are instruments of A/E's service through which the Work to be executed by Contractor is described. Neither Contractor nor any Subcontractor shall own or claim a copyright in the Drawings, Specifications, and other documents prepared by A/E, and A/E shall be deemed the author of them and will, along with any rights of Owner, retain all common law, statutory, and other reserved rights, in addition to the copyright. All copies of these documents, except Contractor's set, shall be returned or suitably accounted for to A/E, on request, upon completion of the Work.
- B. The Drawings, Specifications, and other documents prepared by the A/E, and copies thereof furnished to Contractor, are for use solely with respect to this Project. They are not to be used by Contractor or any

GENERAL CONDITIONS FOR CONSTRUCTION AT WASHINGTON STATE PARKS

Subcontractor on other projects or for additions to this Project outside the scope of the Work without the specific written consent of Owner and A/E. Contractor and Subcontractors are granted a limited license to use and reproduce applicable portions of the Drawings, Specifications, and other documents prepared by A/E appropriate to and for use in the execution of their Work.

- C. Contractor and all Subcontractors grant a non-exclusive license to Owner, without additional cost or royalty, to use for its own purposes (including reproduction) all Shop Drawings, together with the information and diagrams contained therein, prepared by Contractor or any Subcontractor. In providing Shop Drawings, Contractor and all Subcontractors warrant that they have authority to grant to Owner a license to use the Shop Drawings, and that such license is not in violation of any copyright or other intellectual property right. Contractor agrees to defend and indemnify Owner pursuant to the indemnity provisions in section 5.03 and 5.23 from any violations of copyright or other intellectual property rights arising out of Owner's use of the Shop Drawings hereunder, or to secure for Owner, at Contractor's own cost, licenses in conformity with this section.
- D. The Shop Drawings and other submittals prepared by Contractor, Subcontractors of any tier, or its or their equipment or material suppliers, and copies thereof furnished to Contractor, are for use solely with respect to this Project. They are not to be used by Contractor or any Subcontractor of any tier, or material or equipment supplier, on other projects or for additions to this Project outside the scope of the Work without the specific written consent of Owner. The Contractor, Subcontractors of any tier, and material or equipment suppliers are granted a limited license to use and reproduce applicable portions of the Shop Drawings and other submittals appropriate to and for use in the execution of their Work under the Contract Documents.

PART 5 - PERFORMANCE

5.01 CONTRACTOR CONTROL AND SUPERVISION

- A. Contractor shall supervise and direct the Work, using its best skill and attention, and shall perform the Work in a skillful manner. Contractor shall be solely responsible for and have control over construction means, methods, techniques, sequences, and procedures and for coordinating all portions of the Work, unless the Contract Documents give other specific instructions concerning these matters. Contractor shall disclose its means and methods of construction when requested by Owner.
- B. Performance of the Work shall be directly supervised by a competent superintendent who is satisfactory to Owner and has authority to act for Contractor. The superintendent shall not be changed without the prior written consent of Owner. Owner may require Contractor to remove the superintendent from the Work or Project site, if Owner reasonably deems the superintendent incompetent, careless, or otherwise objectionable, provided Owner has first notified Contractor in writing and allowed a reasonable period for transition. The superintendent shall be on-site at all times while the Work is being performed, unless approved in writing by owner, in advance.
- C. Contractor shall be responsible to Owner for acts and omissions of Contractor, Subcontractors, and their employees and agents.
- D. Contractor shall enforce strict discipline and good order among Contractor's employees and other persons performing the Work. Contractor shall not permit employment of persons not skilled in tasks assigned to them. Contractor's employees shall at all times conduct business in a manner which assures fair, equal, and nondiscriminatory treatment of all persons. Owner may, by written notice, request Contractor to remove from the Work or Project site any employee Owner reasonably deems incompetent, careless, or otherwise objectionable.
- E. Contractor shall, at all times, keep on the Project site a copy of the Drawings, Specifications, addenda, reviewed Shop Drawings, permits, and permit drawings.
- F. Contractor shall ensure that its owner(s) and employees, and those of its Subcontractors, comply with the Ethics in Public Service Act RCW 42.52, which, among other things, prohibits state employees from having an economic interest in any public works contract that was made by, or supervised by, that employee. Contractor shall remove, at its sole cost and expense, any of its, or its Subcontractors', employees, if they are in violation of this act.

GENERAL CONDITIONS FOR CONSTRUCTION AT WASHINGTON STATE PARKS

5.02 PERMITS, FEES, AND NOTICES

- A. The Owner has obtained a Shorelines Substantial Development Permit and/or other environmental permits as required for this project. The permits with provisions which affect the construction methods or schedule have been incorporated into these specifications. The Contractor shall abide by all restrictions noted in these permits as the construction is in progress.
- B. All other permits or fees required by local, state or federal governmental agencies necessary for the construction of this project shall be obtained and paid by the Contractor. Only the cost for the building permit will be reimbursed by the Owner.
- C. The Contractor shall conform to all local, State and National Codes in all phases of this project. Where conflicts arise between plans, specifications and code requirements, the code shall prevail unless the plans or specifications are more stringent.

5.03 PATENTS AND ROYALTIES

Contractor is responsible for, and shall pay, all royalties and license fees. Contractor shall defend, indemnify, and hold Owner harmless from any costs, expenses, and liabilities arising out of the infringement by Contractor of any patent, copyright, or other intellectual property right used in the Work; however, provided that Contractor gives prompt notice, Contractor shall not be responsible for such defense or indemnity when a particular design, process, or product of a particular manufacturer or manufacturers is required by the Contract Documents. If Contractor has reason to believe that use of the required design, process, or product constitutes an infringement of a patent or copyright, it shall promptly notify Owner of such potential infringement.

5.04 PREVAILING WAGES

- A. Contractor and all subcontractors shall pay the prevailing rate of wages to all workers, laborers, or mechanics employed in the performance of any part of the Work in accordance with RCW 39.12 and the rules and regulations of the Department of Labor and Industries. The schedule of prevailing wage rates for the locality or localities of the Work is determined by the Industrial Statistician of the Department of Labor and Industries. It is the Contractor's responsibility to verify the applicable prevailing wage rate.
- B. Before payment is made by the Owner to the Contractor for any work performed by the Contractor and subcontractors whose work is included in the application for payment, the Contractor shall submit, or shall have previously submitted to the Owner for the Project, a Statement of Intent to Pay Prevailing Wages, approved by the Department of Labor and Industries, certifying the rate of hourly wage paid and to be paid each classification of laborers, workers, or mechanics employed upon the Work by Contractor and Subcontractors. Such rates of hourly wage shall not be less than the prevailing wage rate.
- C. Prior to release of retainage, the Contractor shall submit to the Owner an Affidavit of Wages Paid, approved by the Department of Labor and Industries, for the Contractor and every subcontractor, of any tier, that performed work on the Project.
- D. Disputes regarding prevailing wage rates shall be referred for arbitration to the Director of the Department of Labor and Industries. The arbitration decision shall be final and conclusive and binding on all parties involved in the dispute as provided for by RCW 39.12.060.
- E. Each Application for Payment submitted by Contractor shall state that prevailing wages have been paid in accordance with the prefiled statement(s) of intent, as approved. Copies of the approved intent statement(s) shall be posted on the job site with the address and telephone number of the Industrial Statistician of the Department of Labor and Industries where a complaint or inquiry concerning prevailing wages may be made.
- F. In compliance with chapter 296-127 WAC, Contractor shall pay to the Department of Labor and Industries the currently established fee(s) for each statement of intent and/or affidavit of wages paid submitted to the Department of Labor and Industries for certification.
- G. Copies of approved Intents to Pay Prevailing Wages for the Contractor and all subcontractors shall be submitted with the Contractor's first application for payment. As additional subcontractors perform work on

GENERAL CONDITIONS FOR CONSTRUCTION AT WASHINGTON STATE PARKS

the project, their approved Intent forms shall be submitted with the Contractor's next application for payment.

- H. The Contractor or subcontractor directly contracting for "Off-Site, Prefabricated, Non-Standard, Project Specific Items" shall identify and report information required on the affidavit of wages paid form filed with the Department of Labor and Industries. The Contractor shall include language in its subcontracts requiring subcontractors and lower-tier subcontractors to comply with the reporting requirements for "Off-Site, Prefabricated, Non-Standard, Project Specific Item(s)" on the affidavit of wages paid.

The reporting requirement for Items shall apply for all public works contracts estimated to cost over \$1 million entered into by the Owner and Contractor between September 1, 2010 and December 31, 2013.

"Off-site, prefabricated, nonstandard, project specific item(s)" means products or items that are:

1. Made primarily of architectural or structural precast concrete, fabricated steel, pipe and pipe systems, or sheet metal and sheet metal duct work;
2. Produced specifically for the public work and not considered to be regularly available shelf items;
3. Produced or manufactured by labor expended to assemble or modify standard items; and
4. Produced at an off-site location outside Washington.

The Contractor or subcontractor shall comply with the reporting requirements and instructions on the affidavit of wages paid form, and shall report the following information on the affidavit of wages paid form submitted to the Department of Labor and Industries in order to comply with the reporting requirements for use of "Off-Site, Prefabricated, Non-Standard, Project Specific item(s)":

1. The estimated cost of the public works project;
2. The name of the awarding agency and the project title;
3. The contract value of the off-site, prefabricated, nonstandard, project specific item(s) produced outside of Washington State, including labor and materials; and
4. The name, address, and federal employer identification number of the contractor that produced the off-site, prefabricated, nonstandard, project specific item(s).

The owner may direct the contractor, at no additional cost to the owner, to remove and substitute any subcontractor(s) found to be out of compliance with the "Off-Site Prefabricated Non-Standard Project Specific Item(s)" reporting requirements more than one time as determined by the Department of Labor and Industries.

- I. The Contractor and all subcontractors shall promptly submit to the Owner certified payroll copies if requested.

5.05 HOURS OF LABOR

- A. Contractor shall comply with all applicable provisions of RCW 49.28 and they are incorporated herein by reference. Pursuant to that statute, no laborer, worker, or mechanic employed by Contractor, any Subcontractor, or any other person performing or contracting to do the whole or any part of the Work, shall be permitted or required to work more than eight (8) hours in any one calendar day, provided, that in cases of extraordinary emergency, such as danger to life or property, the hours of work may be extended, but in such cases the rate of pay for time employed in excess of eight (8) hours of each calendar day shall be not less than one and one-half times (x1.5) the rate allowed for this same amount of time during eight (8) hours service.
- B. Notwithstanding the preceding paragraph, RCW 49.28 permits a contractor or subcontractor in any public works contract subject to those provisions, to enter into an agreement with its employees in which the employees work up to ten (10) hours in a calendar day. No such agreement may provide that the employees work ten-hour days for more than four (4) calendar days a week. Any such agreement is subject to approval by the employees. The overtime provisions of RCW 49.28 shall not apply to the hours, up to forty (40) hours per week, worked pursuant to any such agreement.

5.06 NONDISCRIMINATION

- A. Discrimination in all phases of employment is prohibited by, among other laws and regulations, Title VII of the Civil Rights Act of 1964, the Vietnam Era Veterans Readjustment Act of 1974, sections 503 and 504 of the Vocational Rehabilitation Act of 1973, the Equal Employment Act of 1972, the Age Discrimination Act of

GENERAL CONDITIONS FOR CONSTRUCTION AT WASHINGTON STATE PARKS

1967, the Americans with Disabilities Act of 1990, the Civil Rights Act of 1991, Presidential Executive Order 11246, Executive Order 11375, the Washington State Law Against Discrimination, RCW 49.60, and Gubernatorial Executive Order 85-09. These laws and regulations establish minimum requirements for affirmative action and fair employment practices which Contractor must meet.

- B. During performance of the Work:
1. Contractor shall not discriminate against any employee or applicant for employment because of race, creed, color, national origin, sex, age, marital status, or the presence of any physical, sensory, or mental disability, Vietnam era veteran status, or disabled veteran status, nor commit any other unfair practices as defined in RCW 49.60.
 2. Contractor shall, in all solicitations or advertisements for employees placed by or for it, state that the contractor is an "equal opportunity employer".
 3. Contractor shall send to each labor union, employment agency, or representative of workers with which it has a collective bargaining agreement or other contract or understanding, a notice advising the labor union, employment agency, or workers' representative of Contractor's obligations according to the Contract Documents and RCW 49.60.
 4. Contractor shall permit access to its books, records, and accounts, and to its premises by Owner, and by the Washington State Human Rights Commission, for the purpose of investigation to ascertain compliance with this section of the Contract Documents.
 5. Contractor shall include the provisions of this section in every Subcontract.
- C. Nondiscrimination Requirement. During the term of this Contract, Contractor, including any subcontractor, shall not discriminate on the bases enumerated at RCW 49.60.530(3). In addition, Contractor, including any subcontractor, shall give written notice of this nondiscrimination requirement to any labor organizations with which Contractor, or subcontractor, has a collective bargaining or other agreement.
- D. Obligation to Cooperate. Contractor, including any subcontractor, shall cooperate and comply with any Washington state agency investigation regarding any allegation that Contractor, including any subcontractor, has engaged in discrimination prohibited by this Contract pursuant to RCW 49.60.530(3).
- E. Default. Notwithstanding any provision to the contrary, Owner may suspend Contractor, including any subcontractor, upon notice of a failure to participate and cooperate with any state agency investigation into alleged discrimination prohibited by this Contract, pursuant to RCW 49.60.530(3). Any such suspension will remain in place until Owner receives notification that Contractor, including any subcontractor, is cooperating with the investigating state agency. In the event Contractor, or subcontractor, is determined to have engaged in discrimination identified at RCW 49.60.530(3), Owner may terminate this Contract in whole or in part, and Contractor, subcontractor, or both, may be referred for debarment as provided in RCW 39.26.200. Contractor or subcontractor may be given a reasonable time in which to cure this noncompliance, including implementing conditions consistent with any court-ordered injunctive relief or settlement agreement.
- F. Remedies for Breach. Notwithstanding any provision to the contrary, in the event of Contract termination or suspension for engaging in discrimination, Contractor, subcontractor, or both, shall be liable for contract damages as authorized by law including, but not limited to, any cost difference between the original contract and the replacement or cover contract and all administrative costs directly related to the replacement contract, which damages are distinct from any penalties imposed under Chapter 49.60, RCW. Owner shall have the right to deduct from any monies due to Contractor or subcontractor, or that thereafter become due, an amount for damages Contractor or subcontractor will owe Owner for default under this provision.

5.07 SAFETY PRECAUTIONS

- A. In performing this contract, the Contractor shall provide for protecting the lives and health of employees and other persons; preventing damage to property, materials, supplies, and equipment; and avoid work interruptions. For these purposes, the Contractor shall:

GENERAL CONDITIONS FOR CONSTRUCTION AT WASHINGTON STATE PARKS

1. Follow Washington Industrial Safety and Health Act (WISHA) regional directives and provide a site-specific safety program that will require an accident prevention and hazard analysis plan for the contractor and each subcontractor on the work site. The Contractor shall submit a site-specific safety plan to the Owner's representative prior to the initial scheduled construction meeting.
 2. Provide adequate safety devices and measures including, but not limited to, the appropriate safety literature, notice, training, permits, placement and use of barricades, signs, signal lights, ladders, scaffolding, staging, runways, hoist, construction elevators, shoring, temporary lighting, grounded outlets, wiring, hazardous materials, vehicles, construction processes, and equipment required by Chapter 19.27 RCW, State Building Code (International Building, Electrical, Mechanical, Fire, and Uniform Plumbing Codes); Chapter 212-12 WAC, Fire Marshal Standards, Chapter 49.17 RCW, WISHA; Chapter 296-155 WAC, Safety Standards for Construction Work; Chapter 296-65 WAC; WISHA Asbestos Standard; WAC 296-62-071, Respirator Standard; WAC 296-62, General Occupation Health Standards, WAC 296-24, General Safety and Health Standards, WAC 296-24, General Safety and Health Standards, Chapter 49.70 RCW, and Right to Know Act.
 3. Comply with the State Environmental Policy Act (SEPA), Clean Air Act, Shoreline Management Act, and other applicable federal, state, and local statutes and regulations dealing with the prevention of environmental pollution and the preservation of public natural resources.
 4. Post all permits, notices, and/or approvals in a conspicuous location at the construction site.
 5. Provide any additional measures that the Owner determines to be reasonable and necessary for ensuring a safe environment in areas open to the public. Nothing in this part shall be construed as imposing a duty upon the Owner or A/E to prescribe safety conditions relating to employees, public, or agents of the Contractors.
 6. The Contractor shall make available a list of hazardous products being used on the project, and their respective Material Safety Data Sheets (MSDS) to the Engineer. This information will be required at the pre-construction conference.
- B. In carrying out its responsibilities according to the Contract Documents, Contractor shall protect the lives and health of employees performing the Work and other persons who may be affected by the Work; prevent damage to materials, supplies, and equipment whether on site or stored off-site; and prevent damage to other property at the site or adjacent thereto. Contractor shall comply with all applicable laws, ordinances, rules, regulations, and orders of any public body having jurisdiction for the safety of persons or property or to protect them from damage, injury, or loss; shall erect and maintain all necessary safeguards for such safety and protection; and shall notify owners of adjacent property and utilities when prosecution of the Work may affect them.
- C. Contractor shall maintain an accurate record of exposure data on all incidents relating to the Work resulting in death, traumatic injury, occupational disease, or damage to property, materials, supplies, or equipment. Contractor shall immediately report any such incident to Owner. Owner shall, at all times, have a right of access to all records of exposure.
- D. Contractor shall provide all persons working on the Project site with information and training on hazardous chemicals in their work at the time of their initial assignment, and whenever a new hazard is introduced into their work area.
1. Information. At a minimum, Contractor shall inform persons working on the Project site of:
 - a. The requirements of chapter 296-62 WAC, General Occupational Health Standards;
 - b. Any operations in their work area where hazardous chemicals are present; and
 - c. The location and availability of written hazard communication programs, including the required list(s) of hazardous chemicals and material safety data sheets required by chapter 296-62 WAC.
 2. Training. At a minimum, Contractor shall provide training for persons working on the Project site which includes:

GENERAL CONDITIONS FOR CONSTRUCTION AT WASHINGTON STATE PARKS

- a. Methods and observations that may be used to detect the presence or release of a hazardous chemical in the work area (such as monitoring conducted by the employer, continuous monitoring devices, visual appearance or odor of hazardous chemicals when being released, etc.);
 - b. The physical and health hazards of the chemicals in the work area;
 - c. The measures such persons can take to protect themselves from these hazards, including specific procedures Contractor, or its Subcontractors, or others have implemented to protect those on the Project site from exposure to hazardous chemicals, such as appropriate work practices, emergency procedures, and personal protective equipment to be used; and
 - d. The details of the hazard communications program developed by Contractor, or its Subcontractors, including an explanation of the labeling system and the material safety data sheet, and how employees can obtain and use the appropriate hazard information.
- E. Contractor's responsibility for hazardous, toxic, or harmful substances shall include the following duties:
1. Contractor shall not keep, use, dispose, transport, generate, or sell on or about the Project site, any substances now or hereafter designated as, or which are subject to regulation as, hazardous, toxic, dangerous, or harmful by any federal, state or local law, regulation, statute or ordinance (hereinafter collectively referred to as "hazardous substances", in violation of any such law, regulation, statute, or ordinance, but in no case shall any such hazardous substance be stored more than 90 days on the Project site.
 2. Contractor shall promptly notify Owner of all spills or releases of any hazardous substances which are otherwise required to be reported to any regulatory agency and pay the cost of cleanup. Contractor shall promptly notify Owner of all failures to comply with any federal, state, or local law, regulation, or ordinance; all inspections of the Project site by any regulatory entity concerning the same; all regulatory orders or fines; and all responses or interim cleanup actions taken by or proposed to be taken by any government entity or private party on the Project site.
- F. All Work shall be performed with due regard for the safety of the public. Contractor shall perform the Work so as to cause a minimum of interruption of vehicular traffic or inconvenience to pedestrians. All arrangements to care for such traffic shall be Contractor's responsibilities. All expenses involved in the maintenance of traffic by way of detours shall be borne by Contractor.
- G. In an emergency affecting the safety of life or the Work or of adjoining property, Contractor is permitted to act, at its discretion, to prevent such threatened loss or injury, and Contractor shall so act if so authorized or instructed.
- H. Nothing provided in this section shall be construed as imposing any duty upon Owner or A/E with regard to, or as constituting any express or implied assumption of control or responsibility over, Project site safety, or over any other safety conditions relating to employees or agents of Contractor or any of its Subcontractors, or the public.

5.08 OPERATIONS, MATERIAL HANDLING, AND STORAGE AREAS

- A. Contractor shall confine all operations, including storage of materials, to Owner-approved areas.
- B. Temporary buildings (e.g., storage sheds, shops, offices) and utilities may be provided by Contractor only with the consent of Owner and without expense to Owner. The temporary buildings and utilities shall remain the property of Contractor and shall be removed by Contractor at its expense upon completion of the Work.
- C. Contractor shall use only established roadways or temporary roadways authorized by Owner. When materials are transported in prosecuting the Work, vehicles shall not be loaded beyond the loading capacity recommended by the manufacturer of the vehicle or prescribed by federal, state, or local law or regulation.
- D. Ownership and control of all materials or facility components to be demolished or removed from the Project site by Contractor shall immediately vest in Contractor upon severance of the component from the facility or severance of the material from the Project site. Contractor shall be responsible for compliance with all

GENERAL CONDITIONS FOR CONSTRUCTION AT WASHINGTON STATE PARKS

laws governing the storage and ultimate disposal. Contractor shall provide Owner with a copy of all manifests and receipts evidencing proper disposal when required by Owner or applicable law.

- E. Contractor shall be responsible for the proper care and protection of its materials and equipment delivered to the Project site. Materials and equipment may be stored on the premises subject to approval of Owner. When Contractor uses any portion of the Project site as a shop, Contractor shall be responsible for any repairs, patching, or cleaning arising from such use.
- F. Contractor shall protect and be responsible for any damage or loss to the Work, or to the materials or equipment until the date of Substantial Completion, and shall repair or replace without cost to Owner any damage or loss that may occur, except damages or loss caused by the acts or omissions of Owner. Contractor shall also protect and be responsible for any damage or loss to the Work, or to the materials or equipment, after the date of Substantial Completion, and shall repair or replace without cost to Owner any such damage or loss that might occur, to the extent such damages or loss are caused by the acts or omissions of Contractor, or any Subcontractor.
- G. Any removed item shall be salvaged without undue damage and stockpiled in a neat and orderly fashion in an area designated by the Engineer. All removed items shall remain the property of the Owner, unless, due to their condition, they are rejected by the Engineer. All materials of whatever nature that are rejected shall be properly disposed by the Contractor in compliance with all laws and regulations.
- H. If designated campsites or emergency overflow areas are approved for use, the Contractor shall comply with all campground rules and regulations of the Washington State Parks and Recreation Commission and the park manager.

5.09 PRIOR NOTICE OF EXCAVATION

- A. "Excavation" means an operation in which earth, rock, or other material on or below the ground is moved or otherwise displaced by any means, except the tilling of soil less than 12 (twelve) inches in depth for agricultural purposes, or road ditch maintenance that does not change the original road grade or ditch flow line. Before commencing any excavation, Contractor shall provide notice of the scheduled commencement of excavation to all owners of underground facilities or utilities, through locator services.

5.10 UNFORESEEN PHYSICAL CONDITIONS

- A. If Contractor encounters conditions at the site which are subsurface or otherwise concealed physical conditions which differ materially from those indicated in the Contract Documents, or unknown physical conditions of an unusual nature which differ materially from those ordinarily found to exist and generally recognized as inherent in construction activities of the character provided for in the Contract Documents, then Contractor shall give written notice to Owner promptly and in no event later than 7 (seven) days after the first observance of the conditions. Conditions shall not be disturbed prior to such notice.
- B. If such conditions differ materially and cause a change in Contractor's cost of, or time required for, performance of any part of the Work, the Contractor may be entitled to an equitable adjustment in the Contract Time or Contract Sum, or both, provided it makes a request therefore as provided in part 7.

5.11 PROTECTION OF EXISTING STRUCTURES, EQUIPMENT, VEGETATION, UTILITIES, AND IMPROVEMENTS

- A. Contractor shall protect from damage all existing structures, equipment, improvements, utilities, and vegetation: at or near the Project site; and on adjacent property of a third party, the locations of which are made known to or should be known by Contractor. Contractor shall repair any damage, including that to the property of a third party, resulting from failure to comply with the requirements of the Contract Documents or failure to exercise reasonable care in performing the Work. If Contractor fails or refuses to repair the damage promptly, Owner may have the necessary work performed and charge the cost to Contractor.
- B. Contractor shall only remove trees when specifically authorized to do so, and shall protect vegetation that will remain in place.
- C. In general, the locations of existing major utilities and equipment, whether above ground or underground, are indicated on the drawings. This information has been obtained from utility maps and verbal

GENERAL CONDITIONS FOR CONSTRUCTION AT WASHINGTON STATE PARKS

descriptions. The Engineer does not guarantee the accuracy or completeness of this information. Other above ground or underground facilities not shown on the drawings may be encountered during the course of the work for which the Contractor is fully responsible to properly locate and identify within the construction area.

- D. Existing above ground and underground facilities and appurtenant structures, which includes but is not limited to, power transmission and distribution, telephone, alarm systems, sanitary sewers, gas services, water service and house or yard drains and fences, shall be located, protected, maintained, relocated, rerouted, removed and restored as may be necessary by the Contractor for completion of the work, but in a manner satisfactory to their respective owners and operators of the services and to the Engineer with the least possible interruption to existing services.
- E. The Contractor shall be responsible for location and maintenance of existing utilities and improvements. Under no circumstances will errors or omissions in location of utilities or improvements, whether they be visible from the surface, buried, or otherwise obscured, be considered as a basis for a claim for additional compensation by the Contractor.
- F. All utilities shall be protected and maintained in continuous operation except where special arrangements have been made with the appropriate utility owner. All damaged utilities shall be restored to original condition, subject to the approval of its owner and at the Contractor's own expense.
- G. If requested, the Contractor shall provide record information about locations, depths, and dimensions of lines, appurtenances, and structures, and any other relevant information about electrical power, water, sewer, and other utilities.
- H. The Contractor shall provide the Engineer with the data required to make a detailed set of record plans. This data will be obtained and recorded by the Contractor during construction on plans supplied by the Engineer. The Contractor shall ensure that the data is obtained. Typical information to be gathered includes the locations of:
 - 1. Buried utilities
 - 2. Junctions of sewer wyes
 - 3. Junctions of electrical taps
 - 4. Clean-outs
 - 5. Deflection points of utilities
 - 6. Valves
- I. Procedure for obtaining this information will be developed by the Engineer working with the Contractor.
- J. Contractor shall protect all existing facilities using whatever methods are necessary, subject to the Engineer's approval. Trees, shrubs, vegetation, or lawn shall not be damaged, scarred, or destroyed unless deemed necessary for work on this contract. All trees damaged during construction shall be immediately repaired using SEAL AND HEAL or other materials as directed by the Engineer. Any damage to the above-mentioned items shall be repaired at the Contractor's expense and to the Engineer's satisfaction.
- K. In the event that archaeological resources are found or unearthed on public land during the performance of this contract, the Contractor shall be required to comply with RCW 27.44 and RCW 27.53 and the rules and regulations of the office of Archaeology and Historic Preservation, including compliance with all archaeological excavation permit requirements.

5.12 LAYOUT OF WORK

- A. Contractor shall plan and lay out the Work in advance of operations so as to coordinate all work without delay or revision.
- B. Contractor shall lay out the Work from Owner-established baselines and bench marks indicated on the Drawings, and shall be responsible for all field measurements in connection with the layout. Contractor shall furnish, at its own expense, all stakes, templates, platforms, equipment, tools, materials, and labor required to lay out any part of the Work. Contractor shall be responsible for executing the Work to the lines

GENERAL CONDITIONS FOR CONSTRUCTION AT WASHINGTON STATE PARKS

and grades that may be established. Contractor shall be responsible for maintaining or restoring all stakes and other marks established.

- C. The indicated limits of work shall be the controlling factor in the Contractor's scope of operation and no payment shall be due for work done out of the limits. Damage to areas not in the Contractor's work area shall be repaired at the Contractor's expense. Questions of what constitutes the work area shall be determined by the Engineer. Only the best methods of construction will be allowed.
- D. The Engineer may adjust or relocate any portion of the system to meet site requirements or to improve the system without additional compensation to the Contractor, provided such adjustments do not represent appreciable costs for additional labor and materials.

5.13 MATERIAL AND EQUIPMENT

- A. All equipment, material, and articles incorporated into the Work shall be new and of the most suitable grade for the purpose intended, unless otherwise specifically provided in the Contract Documents. References in the Specifications to equipment, material, articles, or patented processes by trade name, make, or catalog number, shall be regarded as establishing a standard quality and shall not be construed as limiting competition. Contractor may, at its option, use any equipment, material, article, or process that, in the judgment of A/E, is equal to that named in the specifications, unless otherwise specifically provided in the Contract Documents.
- B. Contractor shall do all cutting, fitting, or patching that may be required to make its several parts fit together properly, or receive or be received by work of others set forth in, or reasonably implied by, the Contract Documents. Contractor shall not endanger any work by cutting, excavating, or otherwise altering the Work and shall not cut or alter the work of any other contractor unless approved in advance by Owner.
- C. Should any of the Work be found defective, or in any way not in accordance with the Contract Documents, this work, in whatever stage of completion, may be rejected by Owner.
- D. The Contractor shall furnish proof of equality in all respects to the specified items when proposing alternate brands or materials. Any significant deviations from specifications, drawings, or equality must be noted by the Contractor when submitting alternate products or materials for approval. The Engineer shall be the sole judge of the equality and suitability of any products, materials, or components proposed by the Contractor as alternates to specified items. The Contractor shall bear all costs and make all secondary changes required to incorporate an approved substitute or alternate into the work. No offers for substitution will be acknowledged from suppliers, distributors, manufacturers, or subcontractors.

5.14 AVAILABILITY AND USE OF UTILITY SERVICES

- A. Owner shall make all reasonable utilities available to Contractor from existing outlets and supplies, as specified in the Contract Documents. Unless otherwise provided in the Contract Documents, the utility service consumed shall be charged to or paid for by Contractor at prevailing rates charged to Owner or, where the utility is produced by Owner, at reasonable rates determined by Owner. Contractor will carefully conserve any utilities furnished.
- B. Contractor shall, at its expense and in a skillful manner satisfactory to Owner, install and maintain all necessary temporary connections and distribution lines, together with appropriate protective devices, and all meters required to measure the amount of each utility used for the purpose of determining charges. Prior to the date of Final Acceptance, Contractor shall remove all temporary connections, distribution lines, meters, and associated equipment and materials.

5.15 TESTS AND INSPECTION

- A. Contractor shall maintain an adequate testing and inspection program and perform such tests and inspections as are necessary or required to ensure that the Work conforms to the requirements of the Contract Documents. Contractor shall be responsible for inspection and quality surveillance of all its Work and all Work performed by any Subcontractor. Unless otherwise provided, Contractor shall make arrangements for such tests, inspections, and approvals with an independent testing laboratory or entity acceptable to Owner, or with the appropriate public authority, and shall bear all related costs of tests, inspections, and approvals. Contractor shall give Owner timely notice of when and where tests and

GENERAL CONDITIONS FOR CONSTRUCTION AT WASHINGTON STATE PARKS

inspections are to be made. Contractor shall maintain complete inspection records and make them available to Owner.

- B. Owner may, at any reasonable time, conduct such inspections and tests as it deems necessary to ensure that the Work is in accordance with the Contract Documents. Owner shall promptly notify Contractor if an inspection or test reveals that the Work is not in accordance with the Contract Documents. Unless the subject items are expressly accepted by Owner, such Owner inspection and tests are for the sole benefit of Owner and do not:
 - 1. Constitute or imply acceptance;
 - 2. Relieve Contractor of responsibility for providing adequate quality control measures;
 - 3. Relieve Contractor of responsibility for risk of loss or damage to the Work, materials, or equipment;
 - 4. Relieve Contractor of its responsibility to comply with the requirements of the Contract Documents; or
 - 5. Impair Owner's right to reject defective or nonconforming items, or to avail itself of any other remedy to which it may be entitled.
- C. Neither observations by an inspector retained by Owner, the presence or absence of such inspector on the site, nor inspections, tests, or approvals by others, shall relieve Contractor from any requirement of the Contract Documents, nor is any such inspector authorized to change any term or condition of the Contract Documents.
- D. Contractor shall promptly furnish, without additional charge, all facilities, labor, material and equipment reasonably needed for performing such safe and convenient inspections and tests as may be required by Owner. Owner may charge Contractor any additional cost of inspection or testing when Work is not ready at the time specified by Contractor for inspection or testing, or when prior rejection makes re-inspection or retest necessary. Owner shall perform its inspections and tests in a manner that will cause no undue delay in the Work.
- E. The Owner shall have the right to appoint an Inspector who will have the authority to reject materials or workmanship which does not fulfill the requirements of these specifications. In case of dispute, the Contractor may appeal to the Engineer whose decision shall be final. The acceptance of any material by the Inspector shall not hinder its subsequent rejection if found defective. Rejected materials and workmanship shall be replaced promptly or be made good by the Contractor without additional cost to the Owner.
- F. Contractor shall deliver one (1) key for each type of lock installed on the project to the Engineer to enable the Engineer to enter all facilities under construction for the purpose of inspection. This includes temporary as well as State Parks' key-coded locks. All keys for key-coded locks shall be delivered to the Engineer as they are made available to the Contractor. These coded keys shall then be signed out to the Contractor on an accountable basis for security purposes.

5.16 CORRECTION OF NONCONFORMING WORK

- A. If a portion of the Work is covered contrary to the requirements in the Contract Documents, it must, if required in writing by Owner, be uncovered for Owner's observation and be replaced at the Contractor's expense and without change in the Contract Time.
- B. If, at any time prior to Final Completion, Owner desires to examine the Work, or any portion of it, which has been covered, Owner may request to see such Work and it shall be uncovered by Contractor. If such Work is in accordance with the Contract Documents, the Contractor shall be entitled to an adjustment in the Contract Sum for the costs of uncovering and replacement, and, if completion of the Work is thereby delayed, an adjustment in the Contract Time, provided it makes a request therefore as provided in part 7. If such Work is not in accordance with the Contract Documents, the Contractor shall pay the costs of examination and reconstruction.
- C. Contractor shall promptly correct Work found by Owner not to conform to the requirements of the Contract Documents, whether observed before or after Substantial Completion and whether or not fabricated, installed, or completed. Contractor shall bear all costs of correcting such nonconforming Work, including additional testing and inspections.

GENERAL CONDITIONS FOR CONSTRUCTION AT WASHINGTON STATE PARKS

- D. If, within one year after the date of Substantial Completion of the Work or designated portion thereof, or within one year after the date for commencement of any system warranties established under section 6.08, or within the terms of any applicable special warranty required by the Contract Documents, any of the Work is found to be not in accordance with the requirements of the Contract Documents, Contractor shall correct it promptly after receipt of written notice from Owner to do so. Owner shall give such notice promptly after discovery of the condition. This period of one year shall be extended, with respect to portions of Work first performed after Substantial Completion, by the period of time between Substantial Completion and the actual performance of the Work. Contractor's duty to correct with respect to Work repaired or replaced shall run for one year from the date of repair or replacement. Obligations under this paragraph shall survive Final Acceptance.
- E. Contractor shall remove from the Project site portions of the Work which are not in accordance with the requirements of the Contract Documents and are neither corrected by Contractor nor accepted by Owner.
- F. If Contractor fails to correct nonconforming Work within a reasonable time after written notice to do so, Owner may replace, correct, or remove the nonconforming Work and charge the cost thereof to the Contractor.
- G. Contractor shall bear the cost of correcting destroyed or damaged Work, whether completed or partially completed, caused by Contractor's correction or removal of Work which is not in accordance with the requirements of the Contract Documents.
- H. Nothing contained in this section shall be construed to establish a period of limitation with respect to other obligations which Contractor might have according to the Contract Documents. Establishment of the time period of one (1) year as described in paragraph 5.16D relates only to the specific obligation of Contractor to correct the Work, and has no relationship to the time within which the Contractor's obligation to comply with the Contract Documents may be sought to be enforced, including the time within which such proceedings may be commenced.
- I. If Owner prefers to accept Work which is not in accordance with the requirements of the Contract Documents, Owner may do so instead of requiring its removal and correction, in which case the Contract Sum may be reduced as appropriate and equitable.

5.17 CLEAN UP

Contractor shall at all times keep the Project site, including hauling routes, infrastructures, utilities, and storage areas, free from accumulations of waste materials. Before completing the Work, Contractor shall remove from the premises its rubbish, tools, scaffolding, equipment, and materials. Upon completing the Work, Contractor shall leave the Project site in a clean, neat, and orderly condition satisfactory to Owner. If Contractor fails to clean up as provided herein, and after reasonable notice from Owner, Owner may do so and the cost thereof shall be charged to Contractor.

5.18 ACCESS TO WORK

Contractor shall provide Owner and A/E access to the Work in progress wherever located.

5.19 OTHER CONTRACTS

Owner may undertake or award other contracts for additional work at or near the Project site. Contractor shall reasonably cooperate with the other contractors and with Owner's employees and shall carefully adapt scheduling and perform the Work in accordance with these Contract Documents to reasonably accommodate the other work.

5.20 SUBCONTRACTORS AND SUPPLIERS

- A. The Contractor shall include the language of this paragraph in each of its first tier subcontracts, and shall require each of its subcontractors to include the same language of this section in each of their subcontracts, adjusting only as necessary the terms used for the contracting parties. Upon request of the Owner, the Contractor shall promptly provide documentation to the Owner demonstrating that the subcontractor meets the subcontractor responsibility criteria below. The requirements of this paragraph apply to all subcontractors regardless of tier. At the time of subcontract execution, the Contractor shall verify that each of its first tier subcontractors meets the following bidder responsibility criteria:

GENERAL CONDITIONS FOR CONSTRUCTION AT WASHINGTON STATE PARKS

1. Have a current certificate of registration as a contractor in compliance with chapter 18.27 RCW, which must have been in effect at the time of subcontract bid submittal;
 2. Have a current Washington Unified Business Identifier (UBI) number;
 3. If applicable, have:
 - a. Industrial Insurance (workers' compensation) coverage for the subcontractor's employees working in Washington, as required in Title 51 RCW;
 - b. A Washington Employment Security Department number, as required in Title 50 RCW;
 - c. A Washington Department of Revenue state excise tax registration number, as required in Title 82 RCW;
 - d. An electrical contractor license, if required by Chapter 19.28 RCW;
 - e. An elevator contractor license, if required by Chapter 70.87 RCW.
 4. Not be disqualified from bidding on any public works contract under RCW 39.06.010 or 39.12.065 (3).
 5. On a project subject to the apprenticeship utilization requirements in RCW 39.04.320, not have been found out of compliance by the Washington state apprenticeship and training council for working apprentices out of ratio, without appropriate supervision, or outside their approved work processes as outlined in their standards of apprenticeship under chapter 49.04 RCW for the one-year period immediately preceding the date of the Owner's first advertisement of the project.
- B. Prior to submitting the first Application for Payment, Contractor shall furnish in writing to Owner, on Owner provided form(s), the names, addresses, telephone numbers, and Tax Identification Numbers (TIN) of all subcontractors, as well as suppliers providing materials in excess of \$2,500.00 which Contractor believes to be MBE or WBE owned businesses, or have identified themselves to the Contractor as MBE or WBE, or are Washington State OMWBE certified. The Contractor shall indicate the anticipated dollar value of each MWBE subcontract. Contractor shall utilize subcontractors and suppliers, which are experienced and qualified, and meet the requirements of the Contract Documents, if any. Contractor shall not utilize any subcontractor or supplier to whom the Owner has a reasonable objection, and shall obtain Owner's written consent before making any substitutions or additions. The Owner may direct the Contractor, at no additional cost to the Owner, to remove and substitute any subcontractor(s) found to be out of compliance with the "Off-Site Prefabricated Non-Standard Project Specific Items" reporting requirements more than one time as determined by the Department of Labor and Industries and as defined in EHB 2805 that amends RCW 39.04.
- C. All Subcontracts must be in writing. By appropriate written agreement, Contractor shall require each Subcontractor, so far as applicable to the Work to be performed by the Subcontractor, to be bound to Contractor by terms of the Contract Documents, and to assume toward Contractor all the obligations and responsibilities which Contractor assumes toward Owner in accordance with the Contract Documents. Each Subcontract shall preserve and protect the rights of Owner in accordance with the Contract Documents with respect to the Work to be performed by the Subcontractor so that subcontracting thereof will not prejudice such rights. Where appropriate, Contractor shall require each Subcontractor to enter into similar agreements with Sub-subcontractors. However, nothing in this paragraph shall be construed to alter the contractual relations between Contractor and its Subcontractors with respect to insurance or bonds.
- D. Contractor shall schedule, supervise, and coordinate the operations of all Subcontractors. No Subcontracting of any of the Work shall relieve Contractor from its responsibility for the performance of the Work in accordance with the Contract Documents or any other obligations of the Contract Documents.
- E. Each subcontract agreement for a portion of the Work is hereby assigned by Contractor to Owner provided that:
1. The assignment is effective only after termination by Owner for cause pursuant to section 9.01 and only for those Subcontracts which Owner accepts by notifying the Subcontractor in writing; and
 2. After the assignment is effective, Owner will assume all future duties and obligations toward the Subcontractor which Contractor assumed in the Subcontract.
 3. The assignment is subject to the prior rights of the surety, if any, obligated under any bond provided in accordance with the Contract Documents.

GENERAL CONDITIONS FOR CONSTRUCTION AT WASHINGTON STATE PARKS

5.21 WARRANTY OF CONSTRUCTION

- A. In addition to any special warranties provided elsewhere in the Contract Documents, Contractor warrants that all Work conforms to the requirements of the Contract Documents and is free of any defect in equipment, material, or design furnished, or workmanship performed, by Contractor.
- B. With respect to all warranties, express or implied, for Work performed or materials furnished according to the Contract Documents, Contractor shall:
 - 1. Obtain all warranties that would be given in normal commercial practice;
 - 2. Require all warranties to be executed, in writing, for the benefit of Owner;
 - 3. Enforce all warranties for the benefit of Owner, if directed by Owner; and
 - 4. Be responsible to enforce any subcontractor's, manufacturer's, or supplier's warranty should they extend beyond the period specified in the Contract Documents.
- C. The obligations under this section shall survive Final Acceptance.

5.22 INDEMNIFICATION

- A. Contractor shall defend, indemnify, and hold Owner and A/E harmless from and against all claims, demands, losses, damages, or costs, including but not limited to damages arising out of bodily injury or death to persons and damage to property, caused by or resulting from:
 - 1. The sole negligence of Contractor or any of its Subcontractors;
 - 2. The concurrent negligence of Contractor, or any Subcontractor, but only to the extent of the negligence of Contractor or such Subcontractor; and
 - 3. The use of any design, process, or equipment which constitutes an infringement of any United States patent presently issued, or violates any other proprietary interest, including copyright, trademark, and trade secret.
- B. In any action against Owner and any other entity indemnified in accordance with this section, by any employee of Contractor, its Subcontractors, Sub-subcontractors, agents, or anyone directly or indirectly employed by any of them, the indemnification obligation of this section shall not be limited by a limit on the amount or type of damages, compensation, or benefits payable by or for Contractor or any Subcontractor under RCW Title 51, the Industrial Insurance Act, or any other employee benefit acts. In addition, Contractor waives immunity as to Owner and A/E only, in accordance with RCW Title 51.

5.23 AMERICANS WITH DISABILITIES ACT (ADA) COMPLIANCE

- A. **General Requirements**

The Contractor and subcontractor shall ensure that all work performed under this Contract complies with the Americans with Disabilities Act (ADA), as codified in 28 C.F.R. § 35.151, and the 2010 ADA Standards for Accessible Design. The Contractor and subcontractor shall construct and maintain all accessible features in operable condition and correct any identified deficiencies in a timely manner.
- B. **Accessibility in New Construction and Alterations**
 - 1. All new facilities and alterations to existing facilities shall be designed and constructed in a manner that ensures accessibility and usability for individuals with disabilities, consistent with ADA accessibility standards.
 - 2. Alterations shall, to the maximum extent feasible, ensure the altered area and the associated path of travel comply with accessibility requirements.
 - 3. If technical infeasibility prevents full compliance, the Contractor and subcontractor shall notify the Owner's Representative and submit a written request for determination of technical infeasibility.

GENERAL CONDITIONS FOR CONSTRUCTION AT WASHINGTON STATE PARKS

4. The Contractor and subcontractor shall coordinate with the Owner to ensure that all public notices related to temporary accessibility interruptions are posted on the project site and on designated agency communication channels.
- C. Maintenance and Inspection of Accessible Features
1. The Contractor and subcontractor shall be responsible for maintaining accessible routes, parking, restrooms, and other accessible features in operable condition throughout the duration of the Work.
 2. Any temporary disruptions affecting accessibility shall be scheduled in a manner that minimizes impact and includes reasonable alternative accommodations where feasible.
 3. The Contractor and subcontractor shall notify the Owner immediately if any accessibility feature is found to be non-compliant or requires repair.
- D. Historic Structures
- If the Work involves historic structures or landscapes that are listed or eligible for listing in the National Register of Historic Places, modifications shall be made in compliance with ADA requirements to the maximum extent feasible. The State Historic Preservation Officer (SHPO) must approve any exemptions for alterations that may impact the historic significance of a structure or landscape.
- E. Compliance and Documentation
1. The Contractor and subcontractor shall comply with all applicable local, state, and federal accessibility requirements.
 2. Any non-compliant work shall be corrected at the Contractor's expense prior to final acceptance.
- F. Submission of Progress Reports – Americans with Disabilities Act (ADA) Compliance
- The Contractor shall submit regular progress reports to the Owner, which shall include the following:
1. Status of Accessible Features – Updates on the construction, installation, and maintenance of all accessibility-related features in accordance with ADA standards.
 2. Compliance Issues – Identification of any non-compliance issues encountered, including deviations from ADA accessibility standards, technical infeasibility determinations, or unforeseen site conditions affecting accessibility.
 3. Corrective Actions – Description of corrective actions taken or proposed to address any identified accessibility deficiencies, including timelines for remediation and any required approvals from the Owner.
 4. Temporary Disruptions – Notification of any planned or unplanned interruptions to accessibility features, including measures taken to minimize impacts and alternative accommodations provided.
 5. Final Verification – Prior to Substantial Completion, the Contractor shall provide documentation verifying that all constructed and altered elements comply with applicable ADA requirements, subject to inspection and approval by the Owner.

Failure to comply with the provisions of this section may result in suspension of the Work, withholding of payment or other remedies as deemed necessary by the Owner.

PART 6 - PAYMENTS AND COMPLETION

6.01 CONTRACT SUM

Owner shall pay Contractor the Contract Sum for performance of the Work, in accordance with the Contract Documents. The Contract Sum shall include all taxes imposed by law and properly chargeable to the Project, including sales tax.

6.02 SCHEDULE OF VALUES

Before submitting its first Application for Payment, Contractor shall submit to Owner for approval a breakdown allocating the total Contract Sum to each principle category of work, in such detail as requested by Owner ("Schedule of Values"). The approved Schedule of Values shall include appropriate amounts for demobilization, record drawings, O&M manuals, and any other requirements for Project closeout, and shall be used by Owner as the basis for progress payments. Payment for Work shall be made only for and in accordance with those items included in the Schedule of Values.

GENERAL CONDITIONS FOR CONSTRUCTION AT WASHINGTON STATE PARKS

6.03 APPLICATION FOR PAYMENT

- A. At monthly intervals, unless determined otherwise by Owner, Contractor shall submit to Owner an itemized Application for Payment for Work completed in accordance with the Contract Documents and the approved Schedule of Values. Each application shall be supported by such substantiating data as Owner may require.
- B. By submitting an Application for Payment, Contractor is certifying that all Subcontractors have been paid, less earned retainage in accordance with RCW 60.28.010, as their interests appeared in the last preceding certificate of payment. By submitting an Application for Payment, Contractor is recertifying that the representations set forth in section 1.03 are true and correct, to the best of Contractor's knowledge, as of the date of the Application for Payment.
- C. At the time it submits an Application for Payment, Contractor shall analyze and reconcile, to the satisfaction of Owner, the actual progress of the Work with the Progress Schedule.
- D. If authorized by Owner, the Application for Payment may include request for payment for material delivered to the Project site and suitably stored, or for completed preparatory work. Payment may similarly be requested for material stored off the Project site, provided Contractor complies with or furnishes satisfactory evidence of the following:
 - 1. The material will be placed in a warehouse that is structurally sound, dry, lighted, and suitable for the materials to be stored;
 - 2. The warehouse is located within a 10-mile radius of the Project. Other locations may be utilized, if approved in writing, by Owner;
 - 3. Only materials for the Project are stored within the warehouse (or a secure portion of a warehouse set aside for the Project);
 - 4. Contractor furnishes Owner a certificate of insurance extending Contractor's insurance coverage for damage, fire, and theft to cover the full value of all materials stored, or in transit;
 - 5. The warehouse (or secure portion thereof) is continuously under lock and key, and only Contractor's authorized personnel shall have access;
 - 6. Owner shall at all times have the right of access in company of Contractor;
 - 7. Contractor and its surety assume total responsibility for the stored materials; and
 - 8. Contractor furnishes to Owner certified lists of materials stored, bills of lading, invoices, and other information as may be required, and shall also furnish notice to Owner when materials are moved from storage to the Project site.

6.04 PROGRESS PAYMENTS

- A. Owner shall make progress payments, in such amounts as Owner determines are properly due, within 30 days after receipt of a properly executed Application for Payment. Owner shall notify Contractor in accordance with RCW 39.76 if the Application for Payment does not comply with the requirements of the Contract Documents.
- B. Owner shall retain 5% (five percent) of the amount of each progress payment until forty-five (45) days after Final Acceptance and receipt of all documents required by law or the Contract Documents, including, at Owner's request, consent of surety to release of the retainage. In accordance with RCW 60.28, Contractor may request that monies reserved be retained in a fund by Owner, deposited by Owner in a bank or savings and loan, or placed in escrow with a bank or trust company to be converted into bonds and securities to be held in escrow with interest to be paid to Contractor. Owner may permit Contractor to provide an appropriate bond in lieu of the retained funds.
- C. Title to all Work and materials covered by a progress payment shall pass to Owner at the time of such payment free and clear of all liens, claims, security interests, and encumbrances. Passage of title shall not,

GENERAL CONDITIONS FOR CONSTRUCTION AT WASHINGTON STATE PARKS

however, relieve Contractor from any of its duties and responsibilities for the Work or materials, or waive any rights of Owner to insist on full compliance by Contractor with the Contract Documents.

- D. Payments due and unpaid in accordance with the Contract Documents shall bear interest as specified in RCW 39.76.

6.05 PAYMENTS WITHHELD

- A. Owner may withhold or, on account of subsequently discovered evidence, nullify the whole or part of any payment to such extent as may be necessary to protect Owner from loss or damage for reasons including but not limited to:
1. Work not in accordance with the Contract Documents;
 2. Reasonable evidence that the Work required by the Contract Documents cannot be completed for the unpaid balance of the Contract Sum;
 3. Work by Owner to correct defective Work or complete the Work in accordance with section 5.17;
 4. Failure to perform in accordance with the Contract Documents; or
 5. Cost or liability that may occur to Owner as the result of Contractor's fault or negligent acts or omissions.
- B. In any case where part or all of a payment is going to be withheld for unsatisfactory performance, Owner shall notify Contractor in accordance with RCW 39.76.

6.06 RETAINAGE AND BOND CLAIM RIGHTS

- A. Prior to release of the contract retainage, an "Affidavit of Wages Paid", approved by the Washington State Department of Labor and Industries, must be on file in the Owner's office. Contracts over \$20,000, including tax, necessitate a clearance from the Washington State Department of Revenue and the Washington State Department of Employment Security. The Owner shall initiate action for the releases from the Departments of Revenue and Employment Security.
- B. RCW chapters 39.08 and 60.28, concerning the rights and responsibilities of Contractor and Owner with regard to the performance and payment bonds and retainage, are made a part of the Contract Documents by reference as though fully set forth herein.
- C. In accordance with RCW 60.28, the lien period for filing liens against the contract retainage shall be forty-five (45) days. Persons performing labor or furnishing supplies toward the completion of the contract who intend to file a lien against the contract retainage must do so within forty-five (45) days from the date of Final Acceptance of the contract by the Owner and in the manner as described in RCW 39.08.030.

6.07 SUBSTANTIAL COMPLETION

Substantial Completion is the stage in the progress of the Work (or portion thereof designated and approved by Owner) when the construction is sufficiently complete, in accordance with the Contract Documents, so Owner can fully occupy the Work (or the designated portion thereof) for the use for which it is intended. All Work other than incidental corrective or punch list work shall be completed. Substantial Completion shall not have been achieved if all systems and parts are not functional, if utilities are not connected and operating normally, if all required occupancy permits have not been issued, or if the Work is not accessible by normal vehicular and pedestrian traffic routes. The date Substantial Completion is achieved shall be established in writing by Owner. Contractor may request an early date of Substantial Completion which must be approved by Change Order. Owner's occupancy of the Work or designated portion thereof does not necessarily indicate that Substantial Completion has been achieved.

6.08 PRIOR OCCUPANCY

- A. Owner may, upon written notice thereof to Contractor, take possession of or use any completed or partially completed portion of the Work ("Prior Occupancy") at any time prior to Substantial Completion. Unless otherwise agreed in writing, Prior Occupancy shall not: be deemed an acceptance of any portion of the

GENERAL CONDITIONS FOR CONSTRUCTION AT WASHINGTON STATE PARKS

Work; accelerate the time for any payment to Contractor; prejudice any rights of Owner provided by any insurance, bond, guaranty, or the Contract Documents; relieve Contractor of the risk of loss or any of the obligations established by the Contract Documents; establish a date for termination or partial termination of the assessment of liquidated damages; or constitute a waiver of claims.

- B. Notwithstanding anything in the preceding paragraph, Owner shall be responsible for loss of or damage to the Work resulting from Prior Occupancy. Contractor's one (1) year duty to repair and any system warranties shall begin on building systems activated and used by Owner as agreed in writing by Owner and Contractor.

6.09 FINAL COMPLETION, ACCEPTANCE, AND PAYMENT

- A. Final Completion shall be achieved when the Work is fully and finally complete in accordance with the Contract Documents. The date Final Completion is achieved shall be established by Owner in writing.
- B. Final Acceptance is the formal action of Owner acknowledging Final Completion. Prior to Final Acceptance, Contractor shall, in addition to all other requirements in the Contract Documents, submit to Owner a written notice of any outstanding disputes or claims between Contractor and any of its Subcontractors, including the amounts and other details thereof. Neither Final Acceptance, nor final payment, shall release Contractor or its sureties from any obligations of these Contract Documents or the Public Works Bond, or constitute a waiver of any claims by Owner arising from Contractor's failure to perform the Work in accordance with the Contract Documents.
- C. Acceptance of final payment by Contractor, or any Subcontractor, shall constitute a waiver and release to Owner of all claims by Contractor, or any such Subcontractor, for an increase in the Contract Sum or the Contract Time, and for every act or omission of Owner relating to or arising out of the Work, except for those Claims made in accordance with the procedures, including the time limits, set forth in part 8.

PART 7 - CHANGES

7.01 CHANGES IN THE WORK

- A. Owner may, at any time and without notice to Contractor's surety, order additions, deletions, revisions, or other changes in the Work. These changes in the Work shall be incorporated into the Contract Documents through the execution of Change Orders. If any change in the Work ordered by Owner causes an increase or decrease in the Contract Sum or the Contract Time, an equitable adjustment shall be made as provided in section 7.02 or 7.03, respectively, and such adjustment(s) shall be incorporated into a Change Order.
- B. If Owner desires to order a change in the Work, it may request a written Change Order Proposal (COP) from Contractor. Contractor shall submit a Change Order Proposal within 14 (fourteen) days of the request from Owner, or within such other period as mutually agreed. Contractor's Change Order Proposal shall be full compensation for implementing the proposed change in the Work, including any adjustment in the Contract Sum or Contract Time, and including compensation for all delays in connection with such change in the Work and for any expense or inconvenience, disruption of schedule, or loss of efficiency or productivity occasioned by the change in the Work.
- C. Upon receipt of the Change Order proposal, or a request for equitable adjustment in the Contract Sum or Contract Time, or both, as provided in sections 7.02 and 7.03, Owner may accept or reject the proposal, request further documentation, or negotiate acceptable terms with Contractor. Pending agreement on the terms of the Change Order, Owner may direct Contractor to proceed immediately with the Change Order Work. Contractor shall not proceed with any change in the Work until it has obtained Owner's approval. All Work done pursuant to any Owner-directed change in the Work shall be executed in accordance with the Contract Documents.
- D. If Owner and Contractor reach agreement on the terms of any change in the Work, including any adjustment in the Contract Sum or Contract Time, such agreement shall be incorporated in a Change Order. The Change Order shall constitute full payment and final settlement of all claims for time and for direct, indirect, and consequential costs, including costs of delays, inconvenience, disruption of schedule, or loss of efficiency or productivity, related to any Work either covered or affected by the Change Order, or related to the events giving rise to the request for equitable adjustment.

GENERAL CONDITIONS FOR CONSTRUCTION AT WASHINGTON STATE PARKS

- E. If Owner and Contractor are unable to reach agreement on the terms of any change in the Work, including any adjustment in the Contract Sum or Contract Time, Contractor may at any time in writing, request a final offer from Owner. Owner shall provide Contractor with its written response within 30 (thirty) days of Contractor's request. Owner may also provide Contractor with a final offer at any time. If Contractor rejects Owner's final offer, or the parties are otherwise unable to reach agreement, Contractor's only remedy shall be to file a Claim as provided in part 8.
- F. Field Authorization
 - 1. The Field Authorization (FA) is executed as a directive to proceed with work when the processing time for an approved change order would impact the project.
 - 2. A scope of work must be defined, a maximum not to exceed cost agreed upon, and any estimated modification to the contract completion time determined. The method of final cost verification must be noted and supporting cost data must be submitted in accordance with the requirements of Part 7 of the General Conditions. Upon satisfactory submittal and approval of supporting cost data, the completed FA will be processed into a change order. No payment will be made to the Contractor for FA work until that FA is converted to a Change Order.

7.02 CHANGES IN THE CONTRACT SUM

- A. General Application
 - 1. The Contract Sum shall only be changed by a Change Order. Contractor shall include any request for a change in the Contract Sum in its Change Order Proposal.
 - 2. If the cost of Contractor's performance is changed due to the fault or negligence of Owner, or anyone for whose acts Owner is responsible, Contractor shall be entitled to make a request for an equitable adjustment in the Contract Sum in accordance with the following procedure. No change in the Contract Sum shall be allowed to the extent: Contractor's changed cost of performance is due to the fault or negligence of Contractor, or anyone for whose acts Contractor is responsible; the change is concurrently caused by Contractor and Owner; or the change is caused by an act of Force Majeure as defined in Section 3.05.
 - a. A request for an equitable adjustment in the Contract Sum shall be based on written notice delivered to Owner within 7 (seven) days of the occurrence of the event giving rise to the request. For purposes of this part, "occurrence" means when Contractor knew, or in its diligent prosecution of the Work should have known, of the event giving rise to the request. If Contractor believes it is entitled to an adjustment in the Contract Sum, Contractor shall immediately notify Owner and begin to keep and maintain complete, accurate, and specific daily records. Contractor shall give Owner access to any such records and, if requested shall promptly furnish copies of such records to Owner.
 - b. Contractor shall not be entitled to any adjustment in the Contract Sum for any occurrence of events or costs that occurred more than 7 (seven) days before Contractor's written notice to Owner. The written notice shall set forth, at a minimum, a description of: the event giving rise to the request for an equitable adjustment in the Contract Sum; the nature of the impacts to Contractor and its Subcontractors of any tier, if any; and to the extent possible the amount of the adjustment in Contract Sum requested. Failure to properly give such written notice shall, to the extent Owner's interests are prejudiced, constitute a waiver of Contractor's right to an equitable adjustment.
 - c. Within 30 (thirty) days of the occurrence of the event giving rise to the request, unless Owner agrees in writing to allow an additional period of time to ascertain more accurate data, Contractor shall supplement the written notice provided in accordance with subparagraph a. above with additional supporting data. Such additional data shall include, at a minimum: the amount of compensation requested, itemized in accordance with the procedure set forth herein; specific facts, circumstances, and analysis that confirms not only that Contractor suffered the damages claimed, but that the damages claimed were actually a result of the act, event, or condition complained of and that the Contract Documents provide entitlement to an equitable adjustment to Contractor for

GENERAL CONDITIONS FOR CONSTRUCTION AT WASHINGTON STATE PARKS

such act, event, or condition; and documentation sufficiently detailed to permit an informed analysis of the request by Owner. When the request for compensation relates to a delay, or other change in Contract Time, Contractor shall demonstrate the impact on the critical path, in accordance with section 7.03C. Failure to provide such additional information and documentation within the time allowed or within the format required shall, to the extent Owner's interests are-prejudiced, constitute a waiver of Contractor's right to an equitable adjustment.

- d. Pending final resolution of any request made in accordance with this paragraph, unless otherwise agreed in writing, Contractor shall proceed diligently with performance of the Work.
 - e. Any requests by Contractor for an equitable adjustment in the Contract Sum and in the Contract Time that arise out of the same event(s) shall be submitted together.
3. The value of any Work covered by a Change Order, or of any request for an equitable adjustment in the Contract Sum, shall be determined by one of the following methods:
 - a. On the basis of a fixed price as determined in paragraph 7.02B.
 - b. By application of unit prices to the quantities of the items involved as determined in paragraph 7.02C.
 - c. On the basis of time and material as determined in paragraph 7.02D.
 4. When Owner has requested Contractor to submit a Change Order proposal, Owner may direct Contractor as to which method in subparagraph 3 above to use when submitting its proposal. Otherwise, Contractor shall determine the value of the Work, or a request for an equitable adjustment, on the basis of the fixed price method.

B. Change Order Pricing -- Fixed Price

When the fixed price method is used to determine the value of any Work covered by a Change Order or a request for an equitable adjustment in the Contract Sum, the following procedures shall apply:

1. Contractor's Change Order Proposal, or request for adjustment in the Contract Sum, shall be accompanied by a complete itemization of the costs, including labor, material, subcontractor costs, and overhead and profit. The costs shall be itemized in the manner set forth below, and shall be submitted on breakdown sheets in a form approved by Owner.
2. All costs shall be calculated based upon appropriate industry standard methods of calculating labor, material quantities, and equipment costs.
3. If any of Contractor's pricing assumptions are contingent upon anticipated actions of Owner, Contractor shall clearly state them in the proposal or request for an equitable adjustment.
4. The cost of any additive or deductive changes in the Work shall be calculated as set forth below, except that overhead and profit shall not be included on deductive changes in the Work. Where a change in the Work involves additive and deductive work by the same Contractor or Subcontractor, small tools, overhead, profit, bond, and insurance markups will apply to the net difference.
5. If the total cost of the change in the Work or request for equitable adjustment does not exceed \$1,000, Contractor shall not be required to submit a breakdown if the description of the change in the Work or request for equitable adjustment is sufficiently definitive for Owner to determine fair value.
6. If the total cost of the change in the Work or request for equitable adjustment is between \$1,000 and \$2,500, Contractor may submit a breakdown in the following level of detail if the description of the change in the Work or if the request for equitable adjustment is sufficiently definitive to permit the Owner to determine fair value:
 - a. lump sum labor;
 - b. lump sum material;
 - c. lump sum equipment usage;
 - d. overhead and profit as set forth below; and
 - e. insurance and bond costs as set forth below.

GENERAL CONDITIONS FOR CONSTRUCTION AT WASHINGTON STATE PARKS

7. Any request for adjustment of Contract Sum based upon the fixed price method shall include only the following items:
- a. Craft labor costs: These are the labor costs determined by multiplying the estimated or actual additional number of craft hours needed to perform the change in the Work by the hourly labor costs. Craft hours should cover direct labor, as well as indirect labor due to trade inefficiencies. The hourly costs shall be based on the following:
 - 1) Basic wages and benefits: Hourly rates and benefits as stated on the Department of Labor and Industries approved "statement of intent to pay prevailing wages." Direct supervision shall be a reasonable percentage not to exceed 15% (fifteen percent) of the cost of direct labor. No supervision markup shall be allowed for a working supervisor's hours.
 - 2) Worker's insurance: Direct contributions to the state of Washington for industrial insurance; medical aid; and supplemental pension, by the class and rates established by the Department of Labor and Industries.
 - 3) Federal insurance: Direct contributions required by the Federal Insurance Compensation Act; Federal Unemployment Tax Act; and the State Unemployment Compensation Act.
 - 4) Travel allowance: Travel allowance and/or subsistence, if applicable, not exceeding those allowances established by regional labor union agreements, which are itemized and identified separately.
 - 5) Safety: Cost incurred due to the Washington Industrial Safety and Health Act, which shall be a reasonable percentage not to exceed 2% (two percent) of the sum of the amounts calculated in (1), (2), and (3) above.
 - b. Material costs: This is an itemization of the quantity and cost of materials needed to perform the change in the Work. Material costs shall be developed first from actual known costs, second from supplier quotations or if these are not available, from standard industry pricing guides. Material costs shall consider all available discounts. Freight costs, express charges, or special delivery charges, shall be itemized.
 - c. Equipment costs: This is an itemization of the type of equipment and the estimated or actual length of time the construction equipment appropriate for the Work is or will be used on the change in the Work. Costs will be allowed for construction equipment only if used solely for the changed Work, or for additional rental costs actually incurred by the Contractor. Equipment charges shall be computed on the basis of actual invoice costs or if owned, from the current edition of one of the following sources:
 - 1) Associated General Contractors - Washington State Department of Transportation (AGC-WSDOT) Equipment Rental Agreement; current edition, on the Contract execution date.
 - 2) The state of Washington Utilities and Transportation Commission for trucks used on highways.
 - 3) The National Electrical Contractors Association for equipment used on electrical work.
 - 4) The Mechanical Contractors Association of America for equipment used on mechanical work.

The Data Quest Rental Rate (Blue Book) shall be used as a basis for establishing rental rates of equipment not listed in the above sources. The maximum rate for standby equipment shall not exceed that shown in the AGC WSDOT Equipment Rental Agreement, current edition, on the Contract execution date.
 - d. Allowance for small tools, expendables, and consumable supplies: Small tools consist of tools which cost \$250 or less and are normally furnished by the performing contractor. The maximum rate for small tools shall not exceed the following:

GENERAL CONDITIONS FOR CONSTRUCTION AT WASHINGTON STATE PARKS

- 1) For Contractor, 3% (three percent) of direct labor costs.
- 2) For Subcontractors, 5% (five percent) of direct labor costs.

Expendables and consumable supplies directly associated with the change in Work must be itemized.

- e. Subcontractor costs: This is defined as payments Contractor makes to Subcontractors for changed Work performed by Subcontractors of any tier. The Subcontractors' cost of Work shall be calculated and itemized in the same manner as prescribed herein for Contractor.
- f. Allowance for overhead: This is defined as costs of any kind attributable to direct and indirect delay, acceleration, or impact, added to the total cost to Owner of any change in the Contract Sum but not to the cost of any change in the Contract Time for which contractor has been compensated pursuant to the conditions set forth in Section 7.03. This allowance shall compensate Contractor for all non-craft labor, temporary construction facilities, field engineering, schedule updating, record drawings, home office cost, B&O taxes, office engineering, estimating costs, additional overhead because of extended time, and any other cost incidental to the change in the Work. It shall be strictly limited in all cases to a reasonable amount, mutually acceptable, or if none can be agreed upon to an amount not to exceed the rates below:

1) For projects where the Contract Award Amount is under \$3 million, the following shall apply:

- a) For Contractor, for any Work actually performed by Contractor's own forces, 16% (sixteen percent) of the first \$50,000 of the cost, and 4% (four percent) of the remaining cost, if any.
- b) For each Subcontractor (including lower tier subcontractors), for any Work actually performed by its own forces, 16% (sixteen percent) of the first \$50,000 of the cost, and 4% (four percent) of the remaining cost, if any.
- c) For Contractor, for any work performed by its Subcontractor(s), 6% (six percent) of the first \$50,000 of the amount due each Subcontractor, and 4% (four percent) of the remaining amount if any.
- d) For each Subcontractor, for any Work performed by its Subcontractor(s) of any lower tier, 4% (four percent) of the first \$50,000 of the amount due the sub-Subcontractor, and 2% (two percent) of the remaining amount if any.
- e) The cost to which overhead is to be applied shall be determined in accordance with subparagraphs a.-e. above.

2) For projects where the Contract Award Amount is equal to or exceeds \$3 million, the following shall apply:

- a) For Contractor, for any Work actually performed by Contractor's own forces, 12% (twelve percent) of the first \$50,000 of the cost, and 4% (four percent) of the remaining cost, if any.
- b) For each Subcontractor (including lower tier subcontractors), for any Work actually performed by its own forces, 12% (twelve percent) of the first \$50,000 of the cost, and 4% (four percent) of the remaining cost, if any.
- c) For Contractor, for any Work performed by its Subcontractor(s), 4% (four percent) of the first \$50,000 of the amount due each Subcontractor, and 2% (two percent) of the remaining amount if any.
- d) For each Subcontractor, for any Work performed by its Subcontractor(s) of any lower tier, 4% (four percent) of the first \$50,000 of the amount due the sub-Subcontractor, and 2% (two percent) of the remaining amount if any.

GENERAL CONDITIONS FOR CONSTRUCTION AT WASHINGTON STATE PARKS

- e) The cost to which overhead is to be applied shall be determined in accordance with subparagraphs a.- e. above.
- g. Allowance for profit: This is an amount to be added to the cost of any change in contract sum, but not to the cost of change in Contract Time for which contractor has been compensated pursuant to the conditions set forth in section 7.03. It shall be limited to a reasonable amount, mutually acceptable, or if none can be agreed upon, to an amount not to exceed the rates below:
 - 1) For Contractor or Subcontractor of any tier for work performed by their forces, 6% (six percent) of the cost developed in accordance with Section 7.02 b. 7a.- e.
 - 2) For Contractor or Subcontractor of any tier for work performed by a subcontractor of a lower tier, 4% (four percent) of the Subcontractor cost developed in accordance with Section 7.02 b. 7a. - h.
- h. Cost of change in insurance or bond premium: This is defined as:
 - 1) Contractor's liability insurance: The cost of any changes in Contractor's liability insurance arising directly from execution of the Change Order; and
 - 2) Public works bond: The cost of the additional premium for Contractor's bond arising directly from the changed Work.

The costs of any change in insurance or bond premium shall be added after overhead and allowance for profit are calculated in accordance with subparagraph f. and g. above.

C. Change Order Pricing -- Unit Prices

- 1. Whenever Owner authorizes Contractor to perform Work on a unit-price basis, Owner's authorization shall clearly state:
 - a. Scope of work to be performed;
 - b. Type of reimbursement including pre-agreed rates for material quantities; and
 - c. Cost limit of reimbursement.
- 2. Contractor shall:
 - a. Cooperate with Owner and assist in monitoring the Work being performed. As requested by Owner, Contractor shall identify workers assigned to the Change Order Work and areas in which they are working;
 - b. Leave access as appropriate for quantity measurement; and
 - c. Not exceed any cost limit(s) without Owner's prior written approval.
- 3. Contractor shall submit costs in accordance with paragraph 7.02B. and satisfy the following requirements:
 - a. Unit prices shall include reimbursement for all direct and indirect costs of the Work, including overhead and profit, and bond and insurance costs; and
 - b. Quantities must be supported by field measurement statements signed by Owner.

D. Change Order Pricing -- Time-and-Material Prices

- 1. Whenever Owner authorizes Contractor to perform Work on a time-and-material basis, Owner's authorization shall clearly state:
 - a. Scope of Work to be performed;
 - b. Type of reimbursement including pre-agreed rates, if any, for material quantities or labor; and
 - c. Cost limit of reimbursement.
- 2. Contractor shall:

GENERAL CONDITIONS FOR CONSTRUCTION AT WASHINGTON STATE PARKS

- a. Cooperate with Owner and assist in monitoring the Work being performed. As requested by Owner, identify workers assigned to the Change Order Work and areas in which they are working;
 - b. Identify on daily time sheets all labor performed in accordance with this authorization. Submit copies of daily time sheets within 2 working days for Owner's review;
 - c. Leave access as appropriate for quantity measurement;
 - d. Perform all Work in accordance with this section as efficiently as possible; and
 - e. Not exceed any cost limit(s) without Owner's prior written approval.
3. Contractor shall submit costs in accordance with paragraph 7.02B and additional verification supported by:
- a. Labor detailed on daily time sheets; and
 - b. Invoices for material.

7.03 CHANGES IN THE CONTRACT TIME

- A. The Contract Time shall only be changed by a Change Order. Contractor shall include any request for a change in the Contract Time in its Change Order Proposal.
- B. If the time of Contractor's performance is changed due to an act of Force Majeure, or due to the fault or negligence of Owner or anyone for whose acts Owner is responsible, Contractor shall be entitled to make a request for an equitable adjustment in the Contract Time in accordance with the following procedure. No adjustment in the Contract Time shall be allowed to the extent Contractor's changed time of performance is due to the fault or negligence of Contractor, or anyone for whose acts Contractor is responsible.
1. A request for an equitable adjustment in the Contract Time shall be based on written notice delivered within 7 (seven) days of the occurrence of the event giving rise to the request. If Contractor believes it is entitled to adjustment of Contract Time, Contractor shall immediately notify Owner and begin to keep and maintain complete, accurate, and specific daily records. Contractor shall give Owner access to any such record and if requested, shall promptly furnish copies of such record to Owner.
 2. Contractor shall not be entitled to an adjustment in the Contract Time for any events that occurred more than 7 (seven) days before Contractor's written notice to Owner. The written notice shall set forth, at a minimum, a description of: the event giving rise to the request for an equitable adjustment in the Contract Time; the nature of the impacts to Contractor and its Subcontractors of any tier, if any; and to the extent possible the amount of the adjustment in Contract Time requested. Failure to properly give such written notice shall, to the extent Owner's interests are prejudiced, constitute a waiver of Contractor's right to an equitable adjustment.
 3. Within 30 (thirty) days of the occurrence of the event giving rise to the request, unless Owner agrees in writing to allow an additional period of time to ascertain more accurate data, Contractor shall supplement the written notice provided in accordance with subparagraph 7.03B.2 with additional supporting data. Such additional data shall include, at a minimum: the amount of delay claimed, itemized in accordance with the procedure set forth herein; specific facts, circumstances, and analysis that confirms not only that Contractor suffered the delay claimed, but that the delay claimed was actually a result of the act, event, or condition complained of, and that the Contract Documents provide entitlement to an equitable adjustment in Contract Time for such act, event, or condition; and supporting documentation sufficiently detailed to permit an informed analysis of the request by Owner. Failure to provide such additional information and documentation within the time allowed or within the format required shall, to the extent Owner's interests are prejudiced, constitute a waiver of Contractor's right to an equitable adjustment.
 4. Pending final resolution of any request in accordance with this paragraph, unless otherwise agreed in writing, Contractor shall proceed diligently with performance of the Work.
- C. Any change in the Contract Time covered by a Change Order, or based on a request for an equitable adjustment in the Contract Time, shall be limited to the change in the critical path of Contractor's schedule attributable to the change of Work or event(s) giving rise to the request for equitable adjustment. Any Change Order proposal or request for an adjustment in the Contract Time shall demonstrate the impact on the critical path of the schedule. Contractor shall be responsible for showing clearly on the Progress

GENERAL CONDITIONS FOR CONSTRUCTION AT WASHINGTON STATE PARKS

Schedule that the change or event: had a specific impact on the critical path, and except in case of concurrent delay, was the sole cause of such impact; and could not have been avoided by resequencing of the Work or other reasonable alternatives.

- D. Contractor may request compensation for the cost of a change in Contract Time in accordance with this paragraph, 7.03D, subject to the following conditions:
1. The change in Contract Time shall solely be caused by the fault or negligence of Owner or A/E;
 2. Compensation under this paragraph is limited to changes in Contract Time for which Contractor is not entitled to be compensated under section 7.02;
 3. Contractor shall follow the procedure set forth in paragraph 7.03B;
 4. Contractor shall establish the extent of the change in Contract Time in accordance with paragraph 7.03C; and
 5. The daily cost of any change in Contract Time shall be limited to the items below, less funds that may have been paid pursuant to a change in the Contract Sum that contributed to this change in Contract Time:
 - a. cost of nonproductive field supervision or labor extended because of the delay;
 - b. cost of weekly meetings or similar indirect activities extended because of the delay;
 - c. cost of temporary facilities or equipment rental extended because of the delay;
 - d. cost of insurance extended because of the delay;
 - e. general and administrative overhead in an amount to be agreed upon, but not to exceed 3% (three percent) of Contract Sum divided by the Contract Time for each day of the delay.

PART 8 - CLAIMS AND DISPUTE RESOLUTION

8.01 CLAIMS PROCEDURE

- A. If the parties fail to reach agreement on the terms of any Change Order for Owner-directed Work as provided in section 7.01, or on the resolution of any request for an equitable adjustment in the Contract Sum as provided in section 7.02 or the Contract Time as provided in section 7.03, Contractor's only remedy shall be to file a Claim with Owner as provided in this section.
- B. Contractor shall file its Claim within the earlier of: 120 (one hundred twenty) days from Owner's final offer in accordance with either paragraph 7.01E or the date of Final Acceptance.
- C. The Claim shall be deemed to cover all changes in cost and time (including direct, indirect, impact, and consequential) to which Contractor may be entitled. It shall be fully substantiated and documented. At a minimum, the Claim shall contain the following information:
1. A detailed factual statement of the Claim for additional compensation and time, if any, providing all necessary dates, locations, and items of Work affected by the Claim;
 2. The date on which facts arose which gave rise to the Claim
 3. The name of each employee of Owner or A/E knowledgeable about the Claim;
 4. The specific provisions of the Contract Documents which support the Claim;
 5. The identification of any documents and the substance of any oral communications that support the Claim;
 6. Copies of any identified documents, other than the Contract Documents, that support the Claim;
 7. If an adjustment in the Contract Time is sought: the specific days and dates for which it is sought; the specific reasons Contractor believes an extension in the Contract Time should be granted; and Contractor's analysis of its Progress Schedule to demonstrate the reason for the extension in Contract Time;

GENERAL CONDITIONS FOR CONSTRUCTION AT WASHINGTON STATE PARKS

8. If an adjustment in the Contract Sum is sought, the exact amount sought and a breakdown of that amount into the categories set forth in, and in the detail required by, section 7.02; and
 9. A statement certifying, under penalty of perjury, that the Claim is made in good faith, that the supporting cost and pricing data are true and accurate to the best of Contractor's knowledge and belief, that the Claim is fully supported by the accompanying data, and that the amount requested accurately reflects the adjustment in the Contract Sum or Contract Time for which Contractor believes Owner is liable.
- D. After Contractor has submitted a fully documented Claim that complies with all applicable provisions of parts 7 and 8, Owner shall respond, in writing, to Contractor as follows:
1. If the Claim amount is less than \$50,000, with a decision within 60 (sixty) days from the date the Claim is received; or
 2. If the Claim amount is \$50,000 or more, with a decision within 60 (sixty) days from the date the Claim is received, or with notice to Contractor of the date by which it will render its decision. Owner will then respond with a written decision in such additional time.
- E. To assist in the review of Contractor's Claim, Owner may visit the Project site, or request additional information, in order to fully evaluate the issues raised by the Claim. Contractor shall proceed with performance of the Work pending final resolution of any Claim. Owner's written decision as set forth above shall be final and conclusive as to all matters set forth in the Claim, unless Contractor follows the procedure set forth in section 8.02.
- F. Any Claim of the Contractor against the Owner for damages, additional compensation, or additional time, shall be conclusively deemed to have been waived by the Contractor unless timely made in accordance with the requirements of this section.

8.02 ARBITRATION

- A. If Contractor disagrees with Owner's decision rendered in accordance with paragraph 8.01D, Contractor shall provide Owner with a written demand for arbitration. No demand for arbitration of any such Claim shall be made later than 30 (thirty) days after the date of Owner's decision on such Claim; failure to demand arbitration within said 30-day period shall result in Owner's decision being final and binding upon Contractor and its Subcontractors.
- B. Notice of the demand for arbitration shall be filed with the American Arbitration Association (AAA), with a copy provided to Owner. The parties shall negotiate or mediate under the Voluntary Construction Mediation Rules of the AAA, or mutually acceptable service, before seeking arbitration in accordance with the Construction Industry Arbitration Rules of AAA as follows:
1. Disputes involving \$30,000 or less shall be conducted in accordance with the Northwest Region Expedited Commercial Arbitration Rules; or
 2. Disputes over \$30,000 shall be conducted in accordance with the Construction Industry Arbitration Rules of the AAA, unless the parties agree to use the expedited rules.
- C. All Claims arising out of the Work shall be resolved by arbitration. The judgment upon the arbitration award may be entered, or review of the award may occur, in the superior court having jurisdiction thereof. No independent legal action relating to or arising from the Work shall be maintained.
- D. Claims between Owner and Contractor, Contractor and its Subcontractors, Contractor and A/E, and Owner and A/E shall, upon demand by Owner, be submitted in the same arbitration or mediation.
- E. If the parties resolve the Claim prior to arbitration judgment, the terms of the resolution shall be incorporated in a Change Order. The Change Order shall constitute full payment and final settlement of the Claim, including all claims for time and for direct, indirect, or consequential costs, including costs of delays, inconvenience, disruption of schedule, or loss of efficiency or productivity.

GENERAL CONDITIONS FOR CONSTRUCTION AT WASHINGTON STATE PARKS

8.03 CLAIMS AUDITS

- A. All Claims filed against Owner shall be subject to audit at any time following the filing of the Claim. Failure of Contractor, or Subcontractors of any tier, to maintain and retain sufficient records to allow Owner to verify all or a portion of the Claim or to permit Owner access to the books and records of Contractor, or Subcontractors of any tier, shall constitute a waiver of the Claim and shall bar any recovery.
- B. In support of Owner audit of any Claim, Contractor shall, upon request, promptly make available to Owner the following documents:
1. Daily time sheets and supervisor's daily reports;
 2. Collective bargaining agreements;
 3. Insurance, welfare, and benefits records;
 4. Payroll registers;
 5. Earnings records;
 6. Payroll tax forms;
 7. Material invoices, requisitions, and delivery confirmations;
 8. Material cost distribution worksheet;
 9. Equipment records (list of company equipment, rates, etc.);
 10. Vendors', rental agencies', Subcontractors', and agents' invoices;
 11. Contracts between Contractor and each of its Subcontractors, and all lower-tier Subcontractor contracts and supplier contracts;
 12. Subcontractors' and agents' payment certificates;
 13. Cancelled checks (payroll and vendors);
 14. Job cost report, including monthly totals;
 15. Job payroll ledger;
 16. Planned resource loading schedules and summaries;
 17. General ledger;
 18. Cash disbursements journal;
 19. Financial statements for all years reflecting the operations on the Work. In addition, the Owner may require, if it deems it appropriate, additional financial statements for 3 (three) years preceding execution of the Work;
 20. Depreciation records on all company equipment whether these records are maintained by the company involved, its accountant, or others;
 21. If a source other than depreciation records is used to develop costs for Contractor's internal purposes in establishing the actual cost of owning and operating equipment, all such other source documents;
 22. All non-privileged documents which relate to each and every Claim together with all documents which support the amount of any adjustment in Contract Sum or Contract Time sought by each Claim;
 23. Work sheets or software used to prepare the Claim establishing the cost components for items of the Claim including but not limited to labor, benefits and insurance, materials, equipment, Subcontractors,

GENERAL CONDITIONS FOR CONSTRUCTION AT WASHINGTON STATE PARKS

all documents which establish the time periods, individuals involved, the hours for the individuals, and the rates for the individuals; and

24. Work sheets, software, and all other documents used by Contractor to prepare its bid.

- C. The audit may be performed by employees of Owner or a representative of Owner. Contractor, and its Subcontractors, shall provide adequate facilities acceptable to Owner, for the audit during normal business hours. Contractor, and all Subcontractors, shall make a good faith effort to cooperate with Owner's auditors.

PART 9 - TERMINATION OF THE WORK

9.01 TERMINATION BY OWNER FOR CAUSE

- A. Owner may, upon 7 (seven) days written notice to Contractor and to its surety, terminate (without prejudice to any right or remedy of Owner) the Work, or any part of it, for cause upon the occurrence of any one or more of the following events:
1. Contractor fails to prosecute the Work or any portion thereof with sufficient diligence to ensure Substantial Completion of the Work within the Contract Time;
 2. Contractor is adjudged bankrupt, makes a general assignment for the benefit of its creditors or a receiver is appointed on account of its insolvency;
 3. Contractor fails in a material way to replace or correct Work not in conformance with the Contract Documents;
 4. Contractor repeatedly fails to supply skilled workers or proper materials or equipment;
 5. Contractor repeatedly fails to make prompt payment due to Subcontractors or for labor;
 6. Contractor materially disregards or fails to comply with laws, ordinances, rules, regulations, or orders of any public authority having jurisdiction; or
 7. Contractor is otherwise in material breach of any provision of the Contract Documents.
- B. Upon termination, Owner may at its option:
1. Take possession of the Project site and take possession of or use all materials, equipment, tools, and construction equipment and machinery thereon owned by Contractor to maintain the orderly progress of, and to finish, the Work;
 2. Accept assignment of subcontracts pursuant to section 5.20; and
 3. Finish the Work by whatever other reasonable method it deems expedient.
- C. Owner's rights and duties upon termination are subject to the prior rights and duties of the surety, if any, obligated under any bond provided in accordance with the Contract Documents.
- D. When Owner terminates the Work in accordance with this section, Contractor shall take the actions set forth in paragraph 9.02B, and shall not be entitled to receive further payment until the Work is accepted.
- E. If the unpaid balance of the Contract Sum exceeds the cost of finishing the Work, including compensation for A/E's services and expenses made necessary thereby and any other extra costs or damages incurred by Owner in completing the Work, or as a result of Contractor's actions, such excess shall be paid to Contractor. If such costs exceed the unpaid balance, Contractor shall pay the difference to Owner. These obligations for payment shall survive termination.
- F. Termination of the Work in accordance with this section shall not relieve Contractor or its surety of any responsibilities for Work performed.

GENERAL CONDITIONS FOR CONSTRUCTION AT WASHINGTON STATE PARKS

- G. If Owner terminates Contractor for cause, and it is later determined that none of the circumstances set forth in paragraph 9.01A exist, then such termination shall be deemed a termination for convenience pursuant to section 9.02.

9.02 TERMINATION BY OWNER FOR CONVENIENCE

- A. Owner may, upon written notice, terminate (without prejudice to any right or remedy of Owner) the Work, or any part of it, for the convenience of Owner.
- B. Unless Owner directs otherwise, after receipt of a written notice of termination for either cause or convenience, Contractor shall promptly:
1. Stop performing Work on the date and as specified in the notice of termination;
 2. Place no further orders or subcontracts for materials, equipment, services or facilities, except as may be necessary for completion of such portion of the Work as is not terminated;
 3. Cancel all orders and subcontracts, upon terms acceptable to Owner, to the extent that they relate to the performance of Work terminated;
 4. Assign to Owner all of the right, title, and interest of Contractor in all orders and subcontracts;
 5. Take such action as may be necessary or as directed by Owner to preserve and protect the Work, Project site, and any other property related to this Project in the possession of Contractor in which Owner has an interest; and
 6. Continue performance only to the extent not terminated.
- C. If Owner terminates the Work or any portion thereof for convenience, Contractor shall be entitled to make a request for an equitable adjustment for its reasonable direct costs incurred prior to the effective date of the termination, plus a reasonable allowance for overhead and profit on Work performed prior to termination, plus the reasonable administrative costs of the termination, but shall not be entitled to any other costs or damages, whatsoever, provided however, the total sum payable upon termination shall not exceed the Contract Sum reduced by prior payments. Contractor shall be required to make its request in accordance with the provisions of part 7.
- D. If Owner terminates the Work or any portion thereof for convenience, the Contract Time shall be adjusted as determined by Owner.

PART 10 - MISCELLANEOUS PROVISIONS

10.01 GOVERNING LAW

The Contract Documents and the rights of the parties herein shall be governed by the laws of the state of Washington. Venue shall be in the county in which Owner's principal place of business is located, unless otherwise specified.

10.02 SUCCESSORS AND ASSIGNS

Owner and Contractor respectively bind themselves, their partners, successors, assigns, and legal representatives to the other party hereto and to partners, successors, assigns, and legal representatives of such other party in respect to covenants, agreements, and obligations contained in the Contract Documents. Neither party shall assign the Work without written consent of the other, except that Contractor may assign the Work for security purposes, to a bank or lending institution authorized to do business in the state of Washington. If either party attempts to make such an assignment without such consent, that party shall nevertheless remain legally responsible for all obligations set forth in the Contract Documents.

10.03 MEANING OF WORDS

Unless otherwise stated in the Contract Documents, words which have well-known technical or construction industry meanings are used in the Contract Documents in accordance with such recognized meanings. Reference to standard specifications, manuals, or codes of any technical society, organization, or association, or

GENERAL CONDITIONS FOR CONSTRUCTION AT WASHINGTON STATE PARKS

to the code of any governmental authority, whether such reference be specific or by implication, shall be to the latest standard specification, manual, or code in effect on the date for submission of bids, except as may be otherwise specifically stated. Wherever in these Drawings and Specifications an article, device, or piece of equipment is referred to in the singular manner, such reference shall apply to as many such articles as are shown on the drawings, or required to complete the installation.

10.04 RIGHTS AND REMEDIES

No action or failure to act by Owner or A/E shall constitute a waiver of a right or duty afforded them under the Contract Documents, nor shall such action or failure to act constitute approval of an acquiescence in a breach therein, except as may be specifically agreed in writing.

10.05 CONTRACTOR REGISTRATION

Pursuant to RCW 39.06, Contractor shall be registered or licensed as required by the laws of the State of Washington, including but not limited to RCW 18.27.

10.06 TIME COMPUTATIONS

When computing any period of time, the day of the event from which the period of time begins shall not be counted. The last day is counted unless it falls on a weekend or legal holiday, in which event the period runs until the end of the next day that is not a weekend or holiday. When the period of time allowed is less than 7 (seven) days, intermediate Saturdays, Sundays, and legal holidays are excluded from the computation.

10.07 RECORDS RETENTION

The wage, payroll, and cost records of Contractor, and its Subcontractors, and all records subject to audit in accordance with section 8.03, shall be retained for a period of not less than 6 (six) years after the date of Final Acceptance.

10.08 THIRD-PARTY AGREEMENTS

The Contract Documents shall not be construed to create a contractual relationship of any kind between: A/E and Contractor; Owner and any Subcontractor; or any persons other than Owner and Contractor.

10.09 ANTITRUST ASSIGNMENT

Owner and Contractor recognize that in actual economic practice, overcharges resulting from antitrust violations are in fact usually borne by the purchaser. Therefore, Contractor hereby assigns to Owner any and all claims for such overcharges as to goods, materials, and equipment purchased in connection with the Work performed in accordance with the Contract Documents, except as to overcharges which result from antitrust violations commencing after the Contract Sum is established and which are not passed on to Owner under a Change Order. Contractor shall put a similar clause in its Subcontracts, and require a similar clause in its sub-Subcontracts, such that all claims for such overcharges on the Work are passed to Owner by Contractor.

10.10 MINORITY AND WOMEN'S BUSINESS ENTERPRISES (MWBE) PARTICIPATION

In Accordance with the legislative findings and policies set forth in Chapter 39.19 RCW the State of Washington encourages participation in all of its contracts by MWBE firms certified by the Office of Minority and Women's Business Enterprises (OMWBE). Participation may be either on a direct basis in response to this solicitation or as a subcontractor to a Bidder. Any affirmative action requirements set forth in federal regulations or statutes included or referenced in the contract documents will apply. Bidders may contact OMWBE to obtain information on certified firms for potential subcontractors/suppliers.

- A. When referred to in this Contract, the terms Minority Business Enterprise (MBE) and Women's Business Enterprise (WBE) will be as defined by OMWBE, WAC 326-02-030.
- B. The OMWBE has compiled a directory of certified firms. Copies of this directory may be obtained through the OMWBE. For information regarding the certification process or the certification status of a particular firm, contact:

OMWBE, 406 South Water Street, PO Box 41160, Olympia, WA 98504-1160, telephone (360) 753-9693.

GENERAL CONDITIONS FOR CONSTRUCTION AT WASHINGTON STATE PARKS

C. Eligible MWBEs or M/W firms

MWBE firms utilized for this project for voluntary MWBE goals may be certified by Washington State OMWBE or self identified as minority or women owned (M/W firm).

D. MWBE Voluntary Goals

The Owner has established voluntary goals for MWBE participation for this project. The voluntary goals are set forth in the Advertisement for Bids.

E. If any part of the contract, including the supply of materials and equipment, is anticipated to be subcontracted, then prior to receipt of the first payment, Contractor shall submit, pursuant to Section 5.20 A, a list of all subcontractors/suppliers it intends to use, designate whether any of the subcontractors/suppliers are MWBE firms, indicate the anticipated dollar value of each MWBE subcontract, and provide Tax Identification Number (TIN).

F. If any part of the contract, including the supply of materials and equipment is actually subcontracted during completion of the work, then prior to final acceptance or completion of the contract or as otherwise indicated in the contract documents, the Contractor shall submit a statement of participation indicating what MWBEs were used and the dollar value of their subcontracts.

G. The provisions of this section are not intended to replace or otherwise change the requirements of RCW 39.30.060. If said statute is applicable to this contract then the failure to comply with RCW 39.30.060 will still render a bid non-responsive.

H. The Contractor shall maintain, for at least three years after completion of this contract, relevant records and information necessary to document the level of utilization of MWBEs and other businesses as subcontractors and suppliers in this contract, as well as any efforts the Contractor makes to increase the participation of MWBEs as listed in section I below. The Contractor shall also maintain, for at least three years after completion of this contract, a record of all quotes, bids, estimates, or proposals submitted to the Contractor by all businesses seeking to participate as subcontractors or suppliers in this contract. The state shall have the right to inspect and copy such records. If this contract involves federal funds, Contractor shall comply with all record keeping requirements set forth in any federal rules, regulations, or statutes included or referenced in the contract documents.

I. Bidders should advertise opportunities for subcontractors or suppliers in a manner reasonably designed to provide MWBEs capable of performing the work with timely notice of such opportunities, and all advertisements shall include a provision encouraging participation by MWBE firms. Advertising may be done through general advertisements (e.g. newspapers, journals, etc.) or by soliciting bids directly from MWBEs. Bidders shall provide MWBEs that express interest with adequate and timely information about plans, specifications, and requirements of the contract.

J. Contractors shall not create barriers to open and fair opportunities for all businesses including MWBEs to participate in all State contracts and to obtain or compete for contracts and subcontracts as sources of supplies, equipment, construction and services.

K. Any violation of the mandatory requirements of this part of the contract shall be a material breach of contract for which the Contractor may be subject to a requirement of specific performance, or damages and sanctions provided by contract, by RCW 39.19.090, or by other applicable laws.

10.11 MINIMUM LEVELS OF APPRENTICESHIP PARTICIPATION

In accordance with Executive Order 00-01 the State of Washington may require apprenticeship participation for projects of a certain cost. The bid advertisement and Bid Proposal form shall establish the minimum percentage of apprentice labor hours as compared to the total labor hours.

A. Voluntary workforce diversity goals have been established for the apprentice hours. These goals are that one-fifth (1/5) of the apprentice hours be performed by minorities, and one-sixth (1/6) of the apprentice hours be performed by women.

GENERAL CONDITIONS FOR CONSTRUCTION AT WASHINGTON STATE PARKS

- B. Apprentice participation, under this contract, may be counted towards the required percentage (%) only if the apprentices are from an apprenticeship program registered and approved by the Washington State Apprenticeship and Training Council (RCW 49.04 and WAC 296-04).
- C. Bidders may contact the Department of Labor and Industries, Specialty Compliance Services Division, Apprenticeship Section, P.O. Box 44530, Olympia, WA 98504-4530 by phone at (360) 902-5320, and e-mail at Apprentice@Lni.wa.gov, to obtain information on available apprenticeship programs.
- D. For each project that has apprentice requirements, the contractor shall submit a "Statement of Apprentice/Journeyman Participation" on forms provided by the Department of General Administration, with every request for progress payment. The Contractor shall submit consolidated and cumulative data collected by the Contractor and collected from all subcontractors by the Contractor. The data to be collected and submitted includes the following:
1. Contractor name and address
 2. Contract number
 3. Project name
 4. Contract value
 5. Reporting period "Notice to Proceed" through "Invoicing Date"
 6. Craft/trade/occupation of all (contractor and subcontractor trades working on the project) apprentices and journeymen
 7. Total number of apprentices and total number of hours worked by apprentices, both categorized by gender and ethnicity
 8. Total number of journeymen and total number of hours worked by journeymen, both categorized by gender and ethnicity
 9. Cumulative combined total of apprentice and journeymen labor hours.
 10. Total percentage of apprentice hours worked
 11. No changes to the required percentage (%) of apprentice participation shall be allowed without written approval of the Owner. In any request for the change the Contractor shall clearly demonstrate a good faith effort to comply with the requirements for apprentice participation.
 12. Any substantive violation of the mandatory requirements of this part of the contract may be a material breach of the contract by the Contractor. The Owner may withhold payment pursuant to Part 6.05, stop the work for cause pursuant to Part 3.04, and terminate the contract for cause pursuant to Part 9.01.

10.12 HEADINGS AND CAPTIONS

Headings for convenience only: All headings and captions used in these General Conditions are only for convenience of reference and shall not be used in any way in connection with the meaning, effect, interpretation, construction, or enforcement of the General Conditions, and do not define the limit or describe the scope or intent of any provision of these General Conditions.

10.13 SUBCONTRACTOR PAYMENTS REPORTING REQUIREMENTS

This Contract is subject to compliance tracking using the State's business diversity management system, Access Equity (B2Gnow). Access Equity is web-based and can be accessed at the Office of Minority and Women's Business Enterprises at <https://omwbe.diversitycompliance.com/>. The Contractor and all Subcontractors shall report and confirm receipt of payments made to the Contractor and each Subcontractor through Access Equity.

The Contractor may contact the Owner at contracts@parks.wa.gov for technical assistance in using the Access Equity system. User guides and documentation related to Contractor and Subcontractor access to and use of Access Equity are available online at <https://omwbe.wa.gov/access-equity-help-center>. The Owner reserves the

GENERAL CONDITIONS FOR CONSTRUCTION AT WASHINGTON STATE PARKS

right to withhold payments from the Contractor for non-compliance with this section. For purposes of this section, Subcontractor means any subcontractor working on the Contract, at any tier and regardless of status as certified WMBE or Non-WMBE.

The Contractor shall:

- a. Register and enter all required Subcontractor information into Access Equity no later than 15 days after the Owner creates the Contract Record.
- b. Complete the required user training (two (2) one-hour online sessions) no later than 20 days after the Owner creates the Contract Record.
- c. Report the amount and date of all payments (i) received from the Owner, and (ii) paid to Subcontractors, no later than 30 days, issuance of each payment made by the Owner to the Contractor, unless otherwise specified in writing by the Owner, except that the Contractor shall mark as "Final" and report the final Subcontractor payments) into Access Equity no later than thirty (30) days after the final payment is due the Subcontractor(s) under the Contract, with all payment information entered no later than sixty (60) days after end of fiscal year.
- d. Monitor contract payments and respond promptly to any requests or instructions from the Owner or system-generated messages to check or provide information in Access Equity.
- e. Coordinate with Subcontractors, or Owner when necessary, to resolve promptly any discrepancies between reported and received payments.
- f. Require each Subcontractor to: (i) register in Access Equity and complete the required user training; (ii) verify the amount and date of receipt of each payment from the Contractor or a higher tier Subcontractor, if applicable, through Access Equity; (iii) report payments made to any lower tier Subcontractors, if any, in the same manner as specified herein; (iv) respond promptly to any requests or instructions from the Contractor or system-generated messages to check or provide information in Access Equity; and (v) coordinate with Contractor, or Owner when necessary, to resolve promptly any discrepancies between reported and received payments.

END OF CONDITIONS

/ / / / /

Approved as to Form:
William Van Hook /s/
Asst. Attorney General
02/2007
08/2010 GA Updates – jrc
09/2010 to AAG Schwartz



PREVAILING WAGES (STATE AND FEDERAL)

Instruction for Prevailing Wage Rates

This Public Works project is subject to both Washington State Prevailing Wage (RCW 39.12) and the Federal Davis-Bacon Act (40 U.S.C. 3141 et seq.).

STATE RATES

The State of Washington prevailing wage rates for this public works project, which is located in Mason County, may be found at the following website address of the Department of Labor and Industries:

<https://secure.lni.wa.gov/wagelookup/rates/journey-level-rates>

The prevailing wages for this project are those that are in effect on the date that the bids are due.

FEDERAL RATES

The Federal Wage Determinations for this project are issued by the U.S. Department of Labor. The applicable General Decision(s) are:

- General Decision Number: WA20260053
- Construction Type: Heavy (e.g., Heavy, Building, Highway)
- Source: <https://sam.gov/content/wage-determinations> - Public Buildings or Works

The prevailing wages for this project are those in effect on the date that the bids are due. For Federal rates, if a contract is not awarded within 90 days of bid opening, the rates shall be updated to the most current version available 10 days prior to contract execution.

Contractor to Pay Prevailing Wages

The Contractor shall pay the prevailing rate of wages to all workers, laborers, or mechanics employed in the performance of any part of the Work.

The Contractor must compare the applicable State Wage Rate with the applicable Federal Wage Rate for every job classification. The Contractor shall pay the higher of the two wages.

It is the Contractor's responsibility to verify the applicable prevailing wage rates and ensure full compliance. A copy of the applicable wage rates is available upon request by email at: contracts@parks.wa.gov.

**TWANOH STATE PARK
LAGOON, SHORELINE AND STREAM RESTORATION**

SECTION 010000 – GENERAL REQUIREMENTS

PART 1 - GENERAL

1.1 SPECIAL NOTICE

- A. The site will be available for Work on July 6, 2026.
- B. Upon Contract award, a Limited Notice to Proceed will be issued to enable Contractor to begin procurement of materials with long lead times.
- C. The in-water work window for this project occurs from July 16th to January 14th.
- D. This contract has “Buy America” requirements per the Department of the Interior. See Section 016000 – Quality Requirements, for further information.

1.2 DESCRIPTION OF WORK

- A. This project includes: Removing a concrete bulkhead, expanding an existing saltwater lagoon, constructing a tidal channel, re-planting salvaged native vegetation around the fringe of the new lagoon. This project also includes removing existing riprap and several trees along the shoreline and streambanks; naturalizing the shoreline by installing large woody debris, bioengineered softshore armoring and a deformable gravel berm; performing work within Twanoh Creek that includes expanding the floodplain, installing clusters of large woody debris within the stream and floodplain, removing and replacing a pedestrian bridge and abutments, and installing bioengineered streambanks.

1.3 TIME FOR COMPLETION OF PROJECT

- A. Substantially complete project in accordance with the drawings and specifications within 60 calendar days from date on Notice to Proceed letter. Final completion in accordance with Contract Documents within 30 calendar days from substantial completion date.

1.4 HOURS OF WORK

- A. Work hours are between 7:00 a.m. and & 7:00 p.m. Monday through Friday, excluding national holidays.

1.5 LIQUIDATED DAMAGES

- A. If Contractor fails to complete Contract within stipulated time, an assessment of \$250.00 per day will be made against Contractor for each additional day required to complete contract, unless an extension of time was granted through Change Order. This assessment is to cover Commission’s liquidated damages and is not to be construed as a penalty.

**TWANOH STATE PARK
LAGOON, SHORELINE AND STREAM RESTORATION**

- B. Contract authorizes the Washington State Parks and Recreation Commission to deduct liquidated damages from money due at completion of contract.

1.6 PRE-CONSTRUCTION CONFERENCE

- A. Following notification of award to Contractor, the date for an on-site pre-construction conference will be set. Do not commence Work prior to conference or until written clearance has been obtained from Project Representative.
- B. Furnish Project Representative with following:
 - 1. Complete list of sub-contractors, including business address, telephone numbers, items of Work, and registration numbers. List is to be updated during contract life.
 - 2. Name and contact information of Contractor's staff who is in charge and responsible for site safety and will be on site at all times.
 - 3. A Site-Specific Safety Plan that is in compliance with the Department of Labor and Industries and 000011 – General Conditions specifically for this project.
 - 4. A progress schedule in accordance with General Conditions.
 - 5. A detailed cost breakdown for lump sum bid items. Furnish a fair evaluation of actual cost of each items of Work listed. This will be used in processing Contractor's requests for partial payment. Submittal of breakdown does not affect the Contract terms.
 - 6. Written document detailing plans to comply with 15 percent Apprenticeship Participation requirement stated in Instruction to Bidders 5.1B.
- C. Project Representative will supply a list of hazardous products that could be encountered on Project. Appropriate Safety Data Sheet (SDS) will be on file at park.

1.7 PROGRESS CLEANING

- A. Remove rubbish and debris from park property daily unless otherwise directed do not allow accumulation. Store materials that cannot be removed daily only in areas specified by the Project Representative.
- B. Maintain worksites in a neat and orderly condition.
- C. Cleanup operations are incidental to the Contract and no extra compensation will be made.

1.8 WASHINGTON STATE DEPARTMENT OF TRANSPORTATION (WSDOT)

- A. **None** of WSDOT General Requirements, measurement or payment provisions apply.

1.9 AS-BUILT DRAWINGS

- A. Keep a clean set of full-sized drawings at job site to use to identify changes.

1.10 PROJECT CONDITIONS

**TWANOH STATE PARK
LAGOON, SHORELINE AND STREAM RESTORATION**

- A. Hazardous Materials: It is not expected that hazardous materials will be encountered in the Work.
 - 1. If materials suspected of containing hazardous materials are encountered, do not disturb; immediately notify Project Representative and Owner. Owner will remove hazardous materials under a separate contract.

1.11 PROJECT SIGN

- A. Provide following temporary sign. Sign location is shown on drawings or determined by Project Representative. Upon Project completion, remove sign and restore area to original condition.

1.12 PROJECT SIGN LETTERING

TITLE OF PROJECT:	LAGOON, SHORELINE AND STREAM RESTORATION
NAME OF FACILITY:	TWANOH STATE PARK
NAME OF CONTRACTOR:	(Place Contractor's Name here)
ADDRESS OF CONTRACTOR:	(Place Contractor's Address here)
FUNDING TITLE NUMBER 1:	ESTUARY & SALMON RESTORATION PROGRAM
FUNDING TITLE NUMBER 2:	NATIONAL COASTAL WETLANDS CONSERVATION GRANT

1.13 PARTNERSHIP IN THE CONTRACT

- A. As partners in this contract, both Contractor and Commission recognize the value of a successful Project. Both parties recognize, besides the tangible benefits to Contractor and the Commission, the citizens of Washington State and visitors to Washington State Parks will benefit immensely from the successful completion of a quality Project.

PART 2 - PRODUCTS (NOT USED)

PART 3 - EXECUTION (NOT USED)

**TWANOHO STATE PARK
LAGOON, SHORELINE AND STREAM RESTORATION**

PROJECT SIGN DETAIL

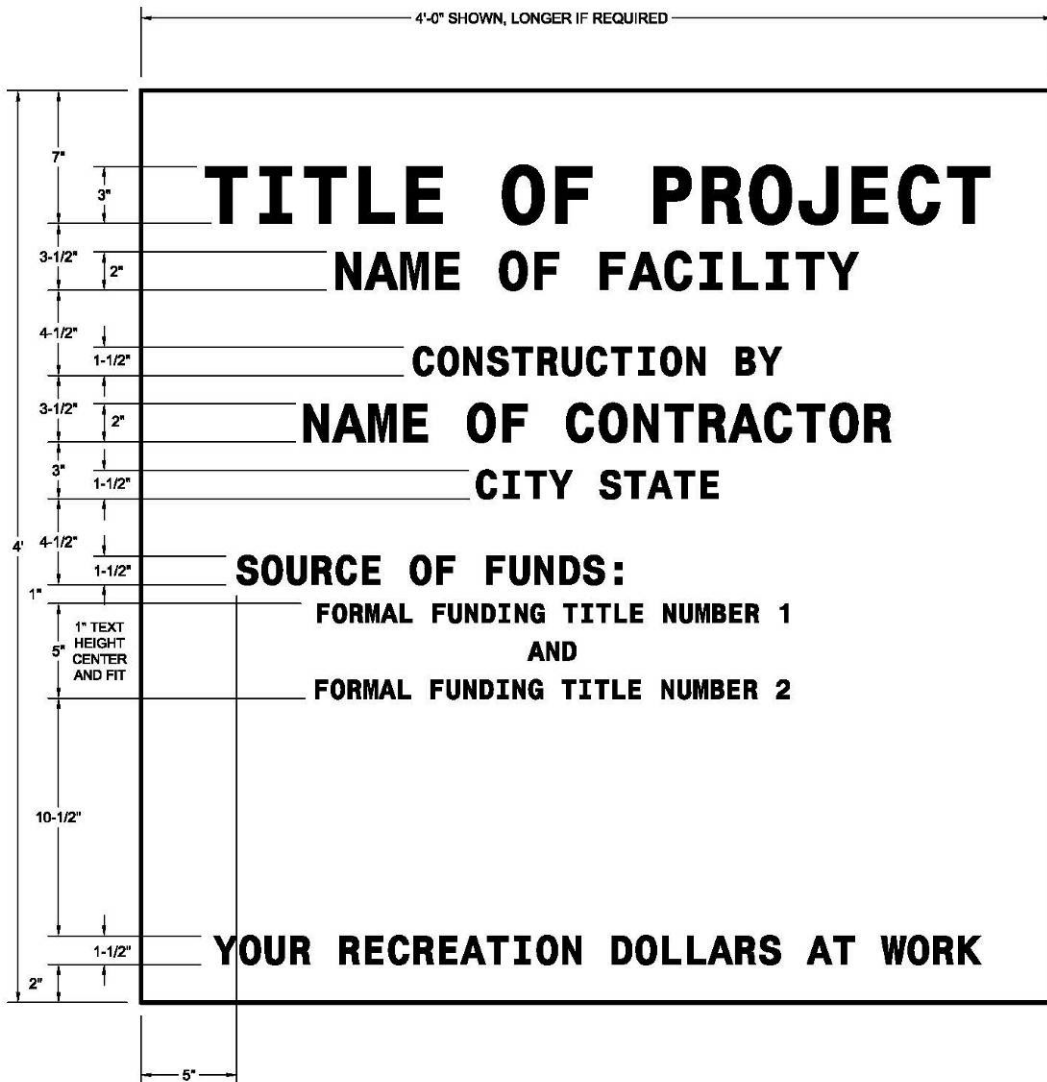

LAY OUT SIGN TO FIT ON A PORTION OF ONE (1) SHEET OF PLYWOOD. IF PLYWOOD IS THE FINAL SURFACE, PAINT IT WITH TWO (2) OR MORE COATS OF WHITE PAINT TO FORM A SMOOTH, NONABSORBENT SURFACE. PROVIDE DARK GREEN WELL FORMED LETTERS, EVENLY SPACED, NEAT IN APPEARANCE, AND ALIGNED AS SHOWN ABOVE.

**WASHINGTON STATE PARKS
PROJECT SIGN DETAIL**

TWANOHO STATE PARK
LAGOON, SHORELINE AND STREAM RESTORATION

PROJECT SIGN DETAIL

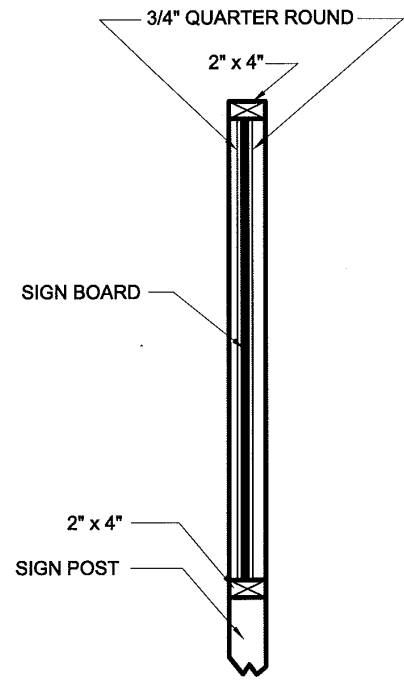
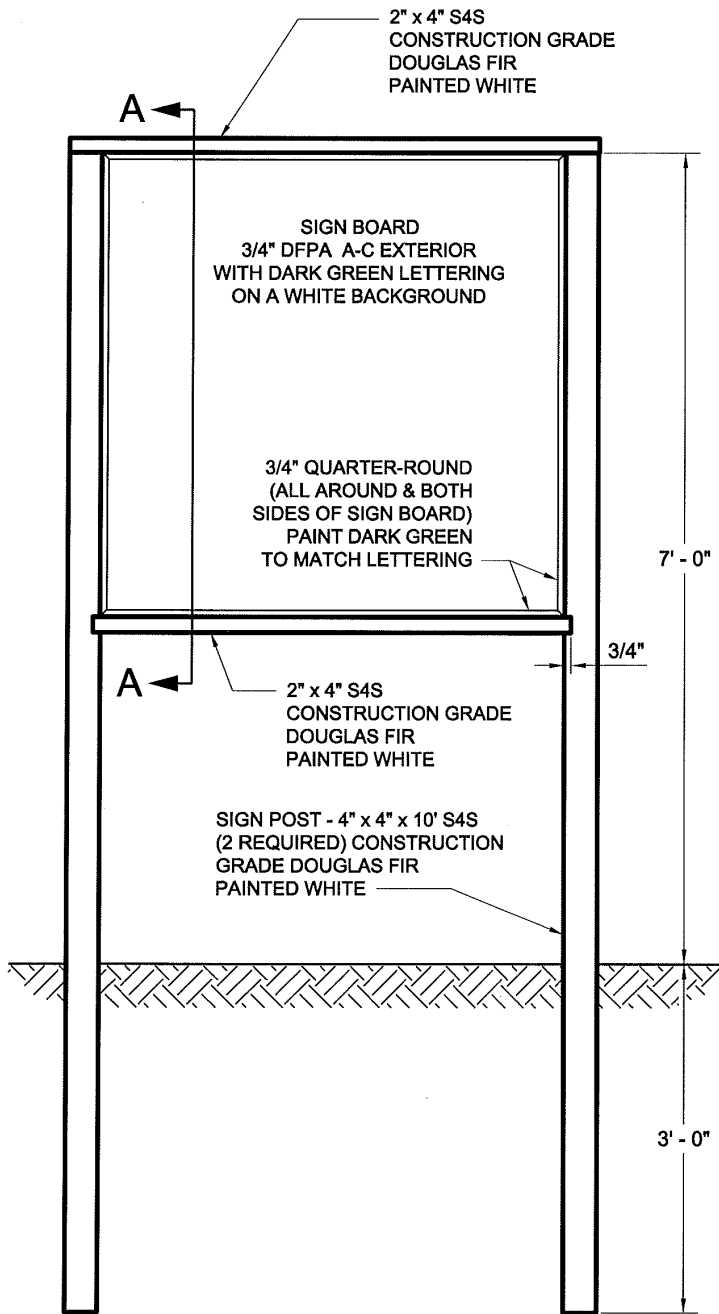

SECTION A - A

END OF SECTION

**TWANOHO STATE PARK
LAGOON, SHORELINE AND STREAM RESTORATION**

SECTION 010099 – SURVEYING

PART 1 - GENERAL

1.1 DESCRIPTION OF WORK

- A. Set and maintain alignment and grades necessary for construction; including clearing limits, grading, utilities, roads, trails, and structures. Except for the data specified to be furnished by the Owner, the Contractor is responsible for calculations, surveying materials and measuring required for setting and maintaining the necessary lines and grades. Furnish copies of calculations and staking data, when requested by Project Representative. Autocad design data will be supplied by the State.
- B. Staking requirements that do not fit field conditions will be reviewed and, if necessary, adjusted by the Engineer. Revisions to the staking information will be provided for completing the work.

1.2 SURVEY CONTROL AND DATA

- A. To facilitate establishment of lines and elevations, Owner will furnish the following survey control and data:
 - 1. Elevation benchmarks, and horizontal control points, for one time only.
 - 2. Provide technical advice, if requested.
- B. Give two weeks' notice to allow adequate time to provide data.

1.3 TOLERANCES

- A. Ensure accuracy of line and elevations within a tolerance of 0.01 foot.
- B. Set subgrade blue tops and surfacing red and yellow tops at 50-foot intervals in tangent sections, 25-foot intervals in curve sections and 10-foot intervals in intersection radii.
- C. In disputes concerning line and elevation accuracy, resolve dispute to Project Representative's satisfaction. Correct discrepancies before proceeding. No additional time or compensation will be provided for corrective work.

1.4 PAYMENT

- A. Lump sum price for "Site Preparation" includes full pay costs for labor, tools, survey instruments, materials, other equipment, and traffic control necessary for the setting and maintaining horizontal locations and grades as specified.

PART 2 – PRODUCTS (NOT USED)

**TWANOH STATE PARK
LAGOON, SHORELINE AND STREAM RESTORATION**

PART 3 – EXECUTION (NOT USED)

END OF SECTION

**TWANOH STATE PARK
LAGOON, SHORELINE AND STREAM RESTORATION**

SECTION 013300 – SUBMITTAL PROCEDURES

PART 1 – GENERAL

1.1 WORK IN THIS SECTION

- A. General: The types of submittal requirements specified in this Section include Shop Drawings, product data, Samples and miscellaneous Work-related submittals. Specialized submittal requirements are specified in applicable Sections for each unit of Work. Refer to other Division 01 Sections and other Contract documents for requirements of administrative submittals.
- B. Definitions: Work-related submittals of this Section are categorized for convenience as follows:
 - 1. Shop Drawings: Specially-prepared technical data for this Project, including Drawings, diagrams, performance curves, data sheets, schedules, templates, patterns, reports, calculations, instructions, measurements and similar information not in standard printed form for general application to several projects.
 - 2. Product Data: Standard printed information on materials, products and systems; not specially-prepared for this Project, other than the designation of selections from among available choices printed therein.
 - 3. Samples: Fabricated and unfabricated physical examples of materials, products and units of Work; both as completed units and as smaller portions of units of Work; either for limited visual inspection or (where indicated) for more detailed testing and analysis.
 - 4. Miscellaneous: Submittals related directly to the Work (non-administrative) include warranties, informational, maintenance agreements, workmanship bonds, Project photographs, survey data and reports, physical Work records, quality testing and certifying reports, copies of industry standards, record drawings, field measurement data, operating and maintenance materials, overrun stock, and similar information, devices and materials applicable to the Work and not processed as Shop Drawings, product data or Samples. See Specification Sections.

1.2 RELATED REQUIREMENTS

- A. General Conditions 4.03
- B. Section 014000 - Quality Requirements
- C. Section 017700 – Closeout Procedures

**TWANOH STATE PARK
LAGOON, SHORELINE AND STREAM RESTORATION**

1.3 GENERAL SUBMITTAL REQUIREMENTS

- A. Coordination and Sequencing: Coordinate preparation and processing of submittals with performance of the Work so that Work will not be delayed by submittals. Coordinate and sequence different categories of submittals for same Work, and for interfacing units of Work, so that one will not be delayed for coordination with another.
- B. Preparation of Submittals: Provide permanent marking on, or with, each submittal to identify Project, date, Contractor, sub-contractor, submittal name and similar information to distinguish it from other submittals.

1.4 SPECIFIC SUBMITTAL REQUIREMENTS

A. General:

- 1. Except as otherwise indicated in individual Work Sections, comply with requirements specified herein for each indicated category of submittal.
- 2. Provide and process intermediate submittals, where required between initial and final, similar to initial submittals.
- 3. Include a transmittal with all submittals.

B. Shop Drawings:

- 1. General: No claims for extras may be initiated, based on Work shown on Shop Drawings.
- 2. Where Work of more than one sub-contractor is involved, submit composite Drawings, clearly defining the Work of each separate sub-contractor.
- 3. No extension of time in respect to the final completion date of building will be granted to Contractor because of failure to have any Shop Drawings submitted in ample time to allow for checking.
- 4. Verify all dimensions by taking field measurements. Do not begin Work until required submittals have been returned by the Engineer with stamp and initials indicating review. If Work has been done which is contrary to the approved Drawings, it will be corrected at no additional cost to the Commission. Maintain one complete set of shop drawings at the site for use by the Engineer.
- 5. Submit four (4) copies. Engineer will retain two (2) copies and return two (2) copies.

C. Product Data:

1. General:

- a. Collect required data into one submittal for each unit of Work or system; and mark each copy to show which choices and options are applicable to Project. Include manufacturer's standard printed recommendations for application and use, compliance with standards, application of labels and seals, notation of field measurements which have been checked, and modify details as required for application into the Work. Include color selection information where necessary.

**TWANOHO STATE PARK
LAGOON, SHORELINE AND STREAM RESTORATION**

- b. Do not proceed with installation of materials, products or systems until final copy of applicable product data is in possession of Installer. Maintain one complete set of product data at the site for use by Project Representative.
 2. Preparation and Processing: Do not submit product data, or allow its use on the Project, until compliance with requirements of Contract documents has been confirmed by Contractor. Submittal is for information and record, unless otherwise indicated. Initial submittal is final submittal unless returned by Engineer, marked with an "Action" which indicates an observed noncompliance.
 3. Submit four (4) copies. Engineer will retain two (2) copies and return two (2) copies to the Contractor.
- D. Samples:
1. General: Provide units identical with final condition of proposed materials or products for the Work. Include "range" Samples (not less than three (3) units) where there are unavoidable variations between units of each set. Provide full set of optional Samples where Engineer's selection is required. Prepare Samples to match Engineer's sample where indicated. Include information with each sample to show generic description, source or product name and manufacturer, limitations, and compliance with standards. Samples are submitted for review and confirmation of color, pattern, texture and "kind" by Engineer. Engineer will not "test" Samples (except as otherwise indicated) for compliance with other requirements, which are, therefore, for exclusive responsibility of the Contractor.
 2. Processing: Submit two (2) sets of Samples for Engineer's review and "Action"; one (1) set will be returned. Large Samples, which may be incorporated into the Work, may be submitted singly.
 3. Reusable Samples: Returned Samples which are intended or permitted to be incorporated in the Work are so indicated in the individual Work sections, and must be in undamaged condition at time of use.
- E. Warranties and Guarantees: In addition to copies desired for Contractor's use, furnish three (3) executed copies, except furnish additional copies where required for maintenance manuals.
- F. Survey Data: Refer to other Sections for specific general requirements on property surveys, field measurements, quantitative records of actual Work, damage surveys, photographs and similar data required by individual Work Sections of these specifications. None of specified copies will be returned.

1.5 ACTION ON SUBMITTALS

- A. Engineer's Action: Engineer will review each submittal, mark with "Action", and where possible return within two (2) weeks of receipt. Where submittal must be held for coordination, they will be returned to the Contractor within two (2) weeks of receipt for the Contractor to resubmit when it is appropriate.
1. Final Unrestricted Release: Work may proceed, provided it complies with Contract documents, when submittal is returned with marking: "Approved as Submitted".

**TWANOHO STATE PARK
LAGOON, SHORELINE AND STREAM RESTORATION**

2. Final-But-Restricted Release: Work may proceed, provided it complies with notations and corrections on submittal and with Contract documents, when submittal is returned with the marking: "Approved as Noted".
3. Returned and Rejected: Do not proceed with Work. Submittal item is not acceptable and may not be used on the Project when noted as "Not Approved".

PART 2 - PRODUCTS (NOT USED)

PART 3 - EXECUTION (NOT USED)

END OF SECTION

**TWANOH STATE PARK
LAGOON, SHORELINE AND STREAM RESTORATION**

SECTION 013501 – INADVERTENT DISCOVERIES OF CULTURAL RESOURCES AND HUMAN SKELETAL REMAINS

PART 1 - GENERAL

1.1 PROJECT SPECIFIC REQUIREMENTS

A. Cultural resource sites are known to exist within Work area, see Special Conditions for requirements.

1. The shoreline east of Twanoh Creek and the lagoon restoration area are considered to have a higher probability for cultural resources that may be present below fill material.

B. Special Conditions:

1. Archaeological monitoring for the shoreline east of Twanoh Creek and the lagoon restoration area is required.

1.2 EMERGENCY CONTACTS

WSPRC Archaeologists

Jennifer Wilson, Archaeology Program Manager	(360) 787-6511 (cell)
Email: jennifer.wilson@parks.wa.gov	(360) 902-8637 (office)
Shari Silverman, Archaeologist SW Region	(435) 260-9894 (cell)
Email: shari.silverman@parks.wa.gov	(360) 902- 8640 (office)
Kayley Bass, Archaeologist SW Region	(360) 701-1277 (cell)
Emails: kayley.bass@parks.wa.gov	

WSPRC Curator of Collections/NAGPRA Specialist

Alicia L. Woods, Statewide Curator of Collections & NAGPRA Specialist (360) 586-0206 (office)

State Physical Anthropologist

Guy Tasa, PhD, Dept. of Archaeology and Historic Preservation (360) 790-1633 (cell)

Assistant State Physical Anthropologist

Julie Berger, Dept. of Archaeology and Historic Preservation (360) 890-2633 (cell)

County Coroner/Examiner

Wes Stockwell, Mason County Coroner's Office (360) 426-4441

Area Manager

Olyvia Buday, South Sound Area Manager (360) 898-1041

Region Manager

Darrel Hopkins, SW Region Manager (SW-North) (360) 725-9781

Local Law Enforcement (if can't get ahold of any park staff)

**TWANOH STATE PARK
LAGOON, SHORELINE AND STREAM RESTORATION**

Paul Lewis, Park Ranger 2

(360) 725-2222

1.3 INADVERTENT DISCOVERIES OF CULTURAL RESOURCES AND HUMAN SKELETAL REMAINS

- A. Many of Washington’s most important heritage sites reside on lands owned or managed by the Washington State Parks and Recreation Commission (WSPRC). Nearly all Washington State Parks contain one or more important historic buildings, structures, or archaeological sites. For this reason, archaeological surveys and historic building inventories are ordinarily commissioned as a part of background analysis and information gathering for park developments and undertakings. Results of these surveys are used during project planning to ensure every effort is made to avoid impacts to cultural resources. Yet, despite these efforts, there **always** remains some potential for unanticipated discoveries while working in Washington State Parks.

- B. All unanticipated discoveries, both cultural resources and human skeletal remains, are subject to all applicable federal and state statues, regulations, and executive orders. For these reasons, the Inadvertent Discovery Plan (IDP) provides useful guidance and instructions for circumstances when cultural resources or human skeletal remains are found. Please carefully read these instructions. If you have any questions, please contact the appropriate WSPRC Area Manager or the WSPRC archaeologist assigned to the undertaking. It is also strongly recommended that anyone conducting ground-disturbing activities watch the training video produced by Washington State Dept of Ecology: [Inadvertent Discovery of Cultural Resources or Human Remains: Training for Field Staff](#). This IDP for cultural resources and human skeletal remains is based on [RCW 27.53](#), [RCW 68.50.645](#), [RCW 27.44.055](#), and [RCW 68.60.055](#) and [recommended language](#) from the Department of Archaeology and Historic Preservation (DAHP).

1.4 INADVERTENT DISCOVERY PLAN FOR CULTURAL RESOURCES

- A. If cultural resources are found during a project, activity in the immediate area of the find should be discontinued (**stop**), the area secured (**protect**), and the WSPRC archaeologists notified to assess the find (**notify**). *When in doubt, assume the material is a cultural resource and implement the IDP outlined below.*

- B. **Recognizing Cultural Resources-Types of Historic/Prehistoric Artifacts and/or Activity Areas That May Be Found**
 - 1. Artifacts- Both historic and prehistoric artifacts may be found exposed in backhoe trenches or back dirt piles.
 - a) Prehistoric artifacts may range from finished tools such as stone pestles, arrowheads/projectile points, shell beads, or polished bone tools to small pieces or “flakes” or “chips” of exotic stone such as chert, jasper, or obsidian.
 - b) Historic artifacts may include older (more than 50 years) nails, plates/ceramics, bottles, cans, coins, glass insulators, or bricks.
 - c) Old abandoned industrial materials from farming, logging, railways, lighthouses, and military installations.
 - 2. Activity Area/Cultural Features- While excavating trench lines look for evidence of buried activity areas/cultural features such as old campfire hearths or buried artifacts.

**TWANOHO STATE PARK
LAGOON, SHORELINE AND STREAM RESTORATION**

- a) An area of charcoal or very dark stained soil with artifacts or burned rocks may be a fire hearth.
 - b) A concentration of shell with or without artifacts may be shell midden deposits.
 - c) Modified or stripped trees, often cedar or aspen, or other modified natural features, such as rock drawings or carvings
3. Historic building foundation/structural remains- During excavation, buried historic structures (e.g., privies, building foundations) that are more than 50 years old may be found.
 4. Bone- Complete or broken pieces of bone may be discovered exposed in trench walls or in back dirt piles. Bone can come from either animal remains or human remains and requires a trained professional to identify. If you find bone, notify the WSPRC archaeologist immediately and follow their directions.

C. STEPS TO TAKE IF A CULTURAL RESOURCE IS FOUND DURING CONSTRUCTION

1. **Stop** if a cultural resource(s) is observed or suspected, all work within the immediate area of the discovery must stop.
2. **Protect** the area from further disturbance. Do not touch, move, or further disturb the exposed materials/artifacts. Create a protected area with temporary fencing, flagging, stakes, or other clear markings that is large enough (30 feet or larger) to protect the discovery location area. The WSPRC archaeologist can help determine the size of the protected area. Do not permit vehicles, equipment, or unauthorized personnel to traverse the discovery site.
3. **Notify** the WSPRC archaeologist. If the area needs to be secured, notify the Park Ranger or Park staff as well.
4. If requested by the WSPRC archaeologist, take photographs with a scale (e.g., pen, coin, etc.) and collect geospatial information of the discovery site to document the initial finds.

D. WHAT NOT TO DO IF A CULTURAL RESOURCE IS FOUND DURING CONSTRUCTION

1. Do not remove any artifacts from the site of the discovery.
2. Do not dig out objects protruding from any trench walls as this may cause further damage to artifacts and/or destroy important contextual information.
3. Do not share any information about the find, including on social media, except as necessary to implement the IDP.

E. WHAT HAPPENS NEXT?

1. The find will be assessed by a professional archaeologist (may be a WSPRC archaeologist or an archaeology consultant).
 - a) If the find is not a cultural resource, construction work may resume.
 - b) If the find is a cultural resource, the WSPRC archaeologist will contact the DAHP and affected Tribes, as appropriate, to develop a suitable treatment plan for the resource.
2. Construction work may resume in the protected area after the WSPRC archaeologist assigned to the undertaking has determined that the find has been adequately investigated and, if necessary, a treatment plan and monitor are in place to protect any remaining archaeological deposits.

**TWANOHO STATE PARK
LAGOON, SHORELINE AND STREAM RESTORATION**

1.5 INADVERTENT DISCOVERY PLAN FOR HUMAN SKELETAL REMAINS

A. Native American burials and historic grave sites are uncommon features on Washington State Park lands. These remains, as well as any associated artifacts or funerary objects, are protected under state law and, if the park is a federal lease, applicable federal law. If you discover human remains (or bones that you believe may be human remains) during construction, please follow these important instructions. It is imperative that reporting and treatment of any human remains found during construction or any ground-disturbing activities are treated with utmost dignity and respect.

B. Steps to Take If Human Skeletal Remains are Found During Construction

1. **Stop** if human skeletal remains observed or suspected, all work within the immediate area of the discovery must stop.
2. **Protect** the area from further disturbance. Do not touch, move, or further disturb the remains. Cover the remains with a tarp or other materials (not soil or rocks) for temporary protection in place and shield them from being photographed. Create a protected area with temporary fencing, flagging, stakes, or other clear markings that is large enough (30 feet or larger) to protect the discovery location area. The WSPRC archaeologist can help determine the size of the protected area. Do not permit vehicles, equipment, or unauthorized personnel to traverse the discovery site.
3. **Notify** law enforcement and the appropriate county medical examiner/coroner as soon as possible. If you are unsure if the remains are human, the physical anthropologist at DAHP may be called. Also notify the Park Ranger, the WSPRC archaeologist, and the WSPRC Curator of Collections/NAGRPA Specialist of the discovery of the remains.
4. If requested by law enforcement, the county coroner/examiner, the DAHP physical anthropologist, or the WSPRC archaeologist, take photographs with a scale (e.g., pen, coin, etc.) and geospatial information of the discovery site to document the initial finds.

C. What Not to Do If Human Skeletal Remains are Found During Construction

1. Do not pick up or remove anything.
2. Do not take any photographs of the remains unless instructed to do so by law enforcement, the county coroner/examiner, the DAHP physical anthropologist, or the WSPRC archaeologist. If pictures are requested, be prepared to photograph them with a scale (e.g., pen, coin, etc.) and collect geospatial information of the remains.
3. Do not call 911 unless you cannot reach law enforcement or the coroner/examiner by other means.
4. Do not share any information about the find, including on social media, except as necessary to implement the IDP.

D. What Happens Next?

1. The county medical examiner/coroner will assume jurisdiction over the human skeletal remains and decide whether those remains are forensic (crime-related) or non-forensic.
 - a) If forensic, the county medical examiner/coroner will retain jurisdiction over the remains.
 - b) If non-forensic, the county medical examiner/coroner will report that finding to the DAHP who will then take jurisdiction over the remains. The DAHP will notify any appropriate cemeteries and all affected Tribes of the remains. The State Physical

**TWANOH STATE PARK
LAGOON, SHORELINE AND STREAM RESTORATION**

Anthropologist will decide whether the remains are Indian or Non-Indian and report that finding to any appropriate cemeteries and the affected Tribes. The DAHP will then handle all consultation with the affected parties as to the future preservation, excavation, and disposition of the remains.

Note: The WSPRC archaeologist assigned to the undertaking will be coordinating and consulting with the DAHP, affected Tribes, and other groups as necessary. Additionally, WSPRC's Curator of Collections/NAGPRA Specialist should be included on all written and/or verbal correspondence until the remains have been officially transferred from WSPRC's possession to an outside authority. Until the remains are transferred off of WSPRC's property, it is the responsibility of the Curator of Collections/NAGPRA Specialist to document and track the information regarding all human remains and associated funerary objects (including all material from excavation areas/units from which the human remains were removed).

2. Construction work may resume in the protected area after the WSPRC archaeologist assigned to the undertaking has determined that the find has been adequately investigated and, if necessary, a treatment plan and monitor are in place.

PART 2 - PRODUCTS (NOT USED)

PART 3 - EXECUTION (NOT USED)

END OF SECTION

**TWANOH STATE PARK
LAGOON, SHORELINE AND STREAM RESTORATION**

SECTION 014000 - QUALITY REQUIREMENTS

1.1 SUMMARY

- A. Section includes administrative and procedural requirements for quality assurance and quality control.
- B. Testing and inspecting services are required to verify compliance with requirements specified or indicated. These services do not relieve Contractor of responsibility for compliance with the Contract Document requirements.
 - 1. Specified tests, inspections, and related actions do not limit Contractor's other quality-assurance and -control procedures that facilitate compliance with the Contract Document requirements.
 - 2. Requirements for Contractor to provide quality-assurance and -control services required by Project Representative, Owner, or Authorities Having Jurisdiction are not limited by provisions of this Section.
- C. Related Requirements:
 - 1. Divisions 02 through 49 Sections for specific test and inspection requirements.

1.2 DEFINITIONS

- A. Quality-Assurance Services: Activities, actions, and procedures performed before and during execution of the Work to guard against defects and deficiencies and substantiate that proposed construction will comply with requirements.
- B. Quality-Control Services: Tests, inspections, procedures, and related actions during and after execution of the Work to evaluate that actual products incorporated into Work and completed construction comply with requirements. Services do not include contract enforcement activities performed by Project Representative.
- C. Mockups: Full-size physical assemblies that are constructed on-site. Mockups are constructed to verify selections made under Sample submittals; to demonstrate aesthetic effects and, where indicated, qualities of materials and execution; to review coordination, testing, or operation; to show interface between dissimilar materials; and to demonstrate compliance with specified installation tolerances. Mockups are not Samples. Unless otherwise indicated, approved mockups establish the standard by which the Work will be judged.
- D. Preconstruction Testing: Tests and inspections performed specifically for Project before products and materials are incorporated into the Work, to verify performance or compliance with specified criteria.
- E. Product Testing: Tests and inspections that are performed by an NRTL, an NVLAP, or a testing agency qualified to conduct product testing and acceptable to Authorities Having Jurisdiction, to establish product performance and compliance with specified requirements.

**TWANOHO STATE PARK
LAGOON, SHORELINE AND STREAM RESTORATION**

- F. Source Quality-Control Testing: Tests and inspections that are performed at the source, e.g., plant, mill, factory, or shop.
- G. Field Quality-Control Testing: Tests and inspections that are performed on-site for installation of the Work and for completed Work.
- H. Testing Agency: An entity engaged to perform specific tests, inspections, or both. Testing laboratory shall mean the same as testing agency.
- I. Installer/Applicator/Erector: Contractor or another entity engaged by Contractor as an employee, Subcontractor, or Sub-subcontractor, to perform a particular construction operation, including installation, erection, application, and similar operations.
 - 1. Use of trade-specific terminology in referring to a trade or entity does not require that certain construction activities be performed by accredited or unionized individuals, or that requirements specified apply exclusively to specific trade(s).
- J. Experienced: When used with an entity or individual, "experienced" means having successfully completed a minimum of five previous projects similar in nature, size, and extent to this Project; being familiar with special requirements indicated; and having complied with requirements of authorities having jurisdiction.

1.3 CONFLICTING REQUIREMENTS

- A. Referenced Standards: If compliance with two or more standards is specified and the standards establish different or conflicting requirements for minimum quantities or quality levels, comply with the most stringent requirement. Refer conflicting requirements that are different, but apparently equal, to Project Representative for a decision before proceeding.
- B. Minimum Quantity or Quality Levels: The quantity or quality level shown or specified shall be the minimum provided or performed. The actual installation may comply exactly with the minimum quantity or quality specified, or it may exceed the minimum within reasonable limits. To comply with these requirements, indicated numeric values are minimum or maximum, as appropriate, for the context of requirements. Refer uncertainties to Project Representative for a decision before proceeding.

1.4 QUANTITY SHEETS/WEIGHT TICKETS

- A. For bulk items, supply quantity sheets (load receipts) to account for each load delivered to the jobsite. Deliver quantity sheets to Inspector on job at delivery time. If Inspector is not on job, deliver quantity sheets on a daily basis to place designated by Project Representative.
- B. No payment shall be made for materials delivered for which quantity tickets have not been turned into Inspector or delivered to designated place at end of working day. Backdated tickets are not acceptable as a basis for payment, except at Project Representative's discretion.
- C. If bid item for material to be delivered to jobsite is stated in TONS, only weight slips from approved scale are acceptable for payment purposes, unless approved in advance by Project Representative.

**TWANOHO STATE PARK
LAGOON, SHORELINE AND STREAM RESTORATION**

- D. No payment for materials will be made until proper accounting has been made. Final quantity records are approved by Project Representative, with payment at Project Representative's discretion.

1.5 INFORMATIONAL SUBMITTALS

- A. Contractor's Statement of Responsibility: When required by Authorities Having Jurisdiction, submit copy of written statement of responsibility sent to Authorities Having Jurisdiction before starting work on the following systems:
1. Seismic-force-resisting system, designated seismic system, or component listed in the designated seismic system quality-assurance plan prepared by Engineer.
 2. Main wind-force-resisting system or a wind-resisting component listed in the wind-force-resisting system quality-assurance plan prepared by Engineer.
- B. Testing Agency Qualifications: For testing agencies specified in "Quality Assurance" Article to demonstrate their capabilities and experience. Include proof of qualifications in the form of a recent report on the inspection of the testing agency by a recognized authority.

1.6 REPORTS AND DOCUMENTS

- A. Test and Inspection Reports: Prepare and submit certified written reports specified in other Sections. Include the following:
1. Date of issue.
 2. Project title and number.
 3. Name, address, and telephone number of testing agency.
 4. Dates and locations of samples and tests or inspections.
 5. Names of individuals making tests and inspections.
 6. Description of the Work and test and inspection method.
 7. Identification of product and Specification Section.
 8. Complete test or inspection data.
 9. Test and inspection results and an interpretation of test results.
 10. Record of temperature and weather conditions at time of sample taking and testing and inspecting.
 11. Comments or professional opinion on whether tested or inspected Work complies with the Contract Document requirements.
 12. Name and signature of laboratory inspector.
 13. Recommendations on retesting and reinspecting.
- B. Manufacturer's Field Reports: Prepare written information documenting tests and inspections specified in other Sections. Include the following:
1. Name, address, and telephone number of representative making report.
 2. Statement on condition of substrates and their acceptability for installation of product.
 3. Summary of installation procedures being followed, whether they comply with requirements and, if not, what corrective action was taken.
 4. Results of operational and other tests and a statement of whether observed performance complies with requirements.

**TWANOH STATE PARK
LAGOON, SHORELINE AND STREAM RESTORATION**

5. Other required items indicated in individual Specification Sections.

- C. Permits, Licenses, and Certificates: For Owner's records, submit copies of permits, licenses, certifications, inspection reports, releases, jurisdictional settlements, notices, receipts for fee payments, judgments, correspondence, records, and similar documents, established for compliance with standards and regulations bearing on performance of the Work.

1.7 QUALITY ASSURANCE

- A. General: Qualifications paragraphs in this article establish the minimum qualification levels required; individual Specification Sections specify additional requirements.
- B. Manufacturer Qualifications: A firm experienced in manufacturing products or systems similar to those indicated for this Project and with a record of successful in-service performance, as well as sufficient production capacity to produce required units.
- C. Fabricator Qualifications: A firm experienced in producing products similar to those indicated for this Project and with a record of successful in-service performance, as well as sufficient production capacity to produce required units.
- D. Installer Qualifications: A firm or individual experienced in installing, erecting, or assembling work similar in material, design, and extent to that indicated for this Project, whose work has resulted in construction with a record of successful in-service performance.
- E. Professional Engineer Qualifications: A professional engineer who is legally qualified to practice in jurisdiction where Project is located and who is experienced in providing engineering services of the kind indicated. Engineering services are defined as those performed for installations of the system, assembly, or product that are similar in material, design, and extent to those indicated for this Project.
- F. Specialists: Certain Specification Sections require that specific construction activities shall be performed by entities who are recognized experts in those operations. Specialists shall satisfy qualification requirements indicated and shall be engaged for the activities indicated.
1. Requirements of Authorities Having Jurisdiction shall supersede requirements for specialists.
- G. Testing Agency Qualifications: An NRTL, an NVLAP, or an independent agency with the experience and capability to conduct testing and inspecting indicated, as documented according to ASTM E 329; and with additional qualifications specified in individual Sections; and, where required by Authorities Having Jurisdiction, that is acceptable to authorities.
1. NRTL: A nationally recognized testing laboratory according to 29 CFR 1910.7.
2. NVLAP: A testing agency accredited according to NIST's National Voluntary Laboratory Accreditation Program.
- H. Manufacturer's Representative Qualifications: An authorized representative of manufacturer who is trained and approved by manufacturer to observe and inspect installation of manufacturer's products that are similar in material, design, and extent to those indicated for this Project.

**TWANOH STATE PARK
LAGOON, SHORELINE AND STREAM RESTORATION**

- I. Preconstruction Testing: Where testing agency is indicated to perform preconstruction testing for compliance with specified requirements for performance and test methods, comply with the following:
1. Contractor responsibilities include the following:
 - a. Provide test specimens representative of proposed products and construction.
 - b. Submit specimens in a timely manner with sufficient time for testing and analyzing results to prevent delaying the Work.
 - c. Build laboratory mockups at testing facility using personnel, products, and methods of construction indicated for the completed Work.
 - d. When testing is complete, remove test specimens, assemblies, and mockups; do not reuse products on Project.
 2. Testing Agency Responsibilities: Submit a certified written report of each test, inspection, and similar quality-assurance service to Project Representative, with copy to Contractor. Interpret tests and inspections and state in each report whether tested and inspected work complies with or deviates from the Contract Documents.
- J. Mockups: Before installing portions of the Work requiring mockups, build mockups for each form of construction and finish required to comply with the following requirements, using materials indicated for the completed Work:
1. Build mockups in location and of size indicated or, if not indicated, as directed by Project Representative.
 2. Notify Project Representative seven days in advance of dates and times when mockups will be constructed.
 3. Demonstrate the proposed range of aesthetic effects and workmanship.
 4. Obtain Project Representative's approval of mockups before starting work, fabrication, or construction.
 - a. Allow seven days for initial review and each re-review of each mockup.
 5. Maintain mockups during construction in an undisturbed condition as a standard for judging the completed Work.
 6. Demolish and remove mockups when directed unless otherwise indicated.

1.8 QUALITY CONTROL

- A. Owner Responsibilities: Where quality-control services are indicated as Owner's responsibility, Owner will engage a qualified testing agency to perform these services.
1. Owner will furnish Contractor with names, addresses, and telephone numbers of testing agencies engaged and a description of types of testing and inspecting they are engaged to perform.
 2. Costs for retesting and reinspecting construction that replaces or is necessitated by work that failed to comply with the Contract Documents will be charged to Contractor, and the Contract Sum will be adjusted by Change Order.

**TWANOH STATE PARK
LAGOON, SHORELINE AND STREAM RESTORATION**

- B. Contractor Responsibilities: Tests and inspections not explicitly assigned to Owner are Contractor's responsibility. Perform additional quality-control activities required to verify that the Work complies with requirements, whether specified or not.
1. Where services are indicated as Contractor's responsibility, engage a qualified testing agency to perform these quality-control services.
 - a. Contractor shall not employ same entity engaged by Owner, unless agreed to in writing by Owner.
 2. Notify testing agencies at least 24 hours in advance of time when Work that requires testing or inspecting will be performed.
 3. Where quality-control services are indicated as Contractor's responsibility, submit a certified written report, in duplicate, of each quality-control service.
 4. Testing and inspecting requested by Contractor and not required by the Contract Documents are Contractor's responsibility.
 5. Submit additional copies of each written report directly to authorities having jurisdiction, when they so direct.
- C. Manufacturer's Field Services: Where indicated, engage a manufacturer's representative to observe and inspect the Work. Manufacturer's representative's services include examination of substrates and conditions, verification of materials, inspection of completed portions of the Work, and submittal of written reports.
- D. Retesting/Reinspecting: Regardless of whether original tests or inspections were Contractor's responsibility, provide quality-control services, including retesting and reinspecting, for construction that replaced Work that failed to comply with the Contract Documents.
- E. Testing Agency Responsibilities: Cooperate with Project Representative, and Contractor in performance of duties. Provide qualified personnel to perform required tests and inspections.
1. Notify Project Representative and Contractor promptly of irregularities or deficiencies observed in the Work during performance of its services.
 2. Determine the location from which test samples will be taken and in which in-situ tests are conducted.
 3. Conduct and interpret tests and inspections and state in each report whether tested and inspected work complies with or deviates from requirements.
 4. Submit a certified written report, in duplicate, of each test, inspection, and similar quality-control service through Contractor.
 5. Do not release, revoke, alter, or increase the Contract Document requirements or approve or accept any portion of the Work.
 6. Do not perform any duties of Contractor.
- F. Associated Services: Cooperate with agencies performing required tests, inspections, and similar quality-control services, and provide reasonable auxiliary services as requested. Notify agency sufficiently in advance of operations to permit assignment of personnel. Provide the following:
1. Access to the Work.
 2. Incidental labor and facilities necessary to facilitate tests and inspections.

**TWANOH STATE PARK
LAGOON, SHORELINE AND STREAM RESTORATION**

3. Adequate quantities of representative samples of materials that require testing and inspecting. Assist agency in obtaining samples.
 4. Facilities for storage and field curing of test samples.
 5. Delivery of samples to testing agencies.
 6. Preliminary design mix proposed for use for material mixes that require control by testing agency.
 7. Security and protection for samples and for testing and inspecting equipment at Project site.
- G. Coordination: Coordinate sequence of activities to accommodate required quality-assurance and -control services with a minimum of delay and to avoid necessity of removing and replacing construction to accommodate testing and inspecting.
1. Schedule times for tests, inspections, obtaining samples, and similar activities.

1.9 SPECIAL TESTS AND INSPECTIONS

- A. Special Tests and Inspections: Owner will engage a qualified testing agency or special inspector to conduct special tests and inspections required by authorities having jurisdiction as the responsibility of Owner and as follows:
1. Verifying that manufacturer maintains detailed fabrication and quality-control procedures and reviews the completeness and adequacy of those procedures to perform the Work.
 2. Notifying Project Representative and Contractor promptly of irregularities and deficiencies observed in the Work during performance of its services.
 3. Submitting a certified written report of each test, inspection, and similar quality-control service to Project Representative with copy to Contractor and to Authorities Having Jurisdiction.
 4. Submitting a final report of special tests and inspections at Substantial Completion, which includes a list of unresolved deficiencies.
 5. Interpreting tests and inspections and stating in each report whether tested and inspected work complies with or deviates from the Contract Documents.
 6. Retesting and reinspecting corrected work.
 7. The Project Representative shall inspect and approve streambed components including gravel and boulder material at acquisition site prior to delivery.
 8. The Project Representative shall inspect and approve the culvert at acquisition site prior to delivery.

PART 2 - PRODUCTS (NOT USED)

PART 3 - EXECUTION

3.1 TEST AND INSPECTION LOG

- A. Test and Inspection Log: Prepare a record of tests and inspections. Include the following:
1. Date test or inspection was conducted.
 2. Description of the Work tested or inspected.

**TWANOH STATE PARK
LAGOON, SHORELINE AND STREAM RESTORATION**

3. Date test or inspection results were transmitted to Project Representative.
 4. Identification of testing agency or special inspector conducting test or inspection.
- B. Maintain log at Project site. Post changes and revisions as they occur. Provide access to test and inspection log for Project Representative's reference during normal working hours.

3.2 REPAIR AND PROTECTION

- A. General: On completion of testing, inspecting, sample taking, and similar services, repair damaged construction and restore substrates and finishes.
1. Provide materials and comply with installation requirements specified in other Specification Sections or matching existing substrates and finishes. Restore patched areas and extend restoration into adjoining areas with durable seams that are as invisible as possible.
- B. Protect construction exposed by or for quality-control service activities.
- C. Repair and protection are Contractor's responsibility, regardless of the assignment of responsibility for quality-control services.

END OF SECTION

**TWANOH STATE PARK
LAGOON, SHORELINE AND STREAM RESTORATION**

SECTION 014100 - REGULATORY REQUIREMENTS

PART 1 - GENERAL

1.1 PERMITS, CODES AND REGULATIONS

A. The following permits have been applied for (or are on file) and incorporated into the contract:

1. S.E.P.A.
2. Shoreline Exemption
3. Mason County Building Permit
4. Hydraulic Project Approval (HPA)
5. Army Corps of Engineers – Section 404 Permit
6. WSDOE – 401 Water Quality Certification

B. Permit restrictions:

1. Timing Restrictions: The in-water work window for this project will be July 16th to January 14th.

C. Conform with the requirements of listed permits and additional or other applicable permits, codes, and regulations as may govern Work.

D. Obtain and pay fees for licenses, permits, inspections, and approvals required by laws, ordinances, and rules of appropriate governing or approving agencies necessary for proper completion of Work (other than those listed under item 1.1A. above and Special Inspections called for by the International Building Code).

E. Conform with current applicable codes, regulations and standards, which is the minimum standard of quality for material and workmanship. Provide labor, materials, and equipment necessary for compliance with code requirements or interpretations, although not specifically detailed in the Drawings or specifications. Be familiar with applicable codes and standards prior to bidding.

F. Process through Project Representative, requests to extend, modify, revise, or renew any of the permits (listed in 1.1A above). Furnish requests in writing and include a narrative description and adequate Drawings to clearly describe and depict proposed action. Do not contact regulatory agency with requests for permit extensions, modifications, revisions, or renewals without the prior written consent of Project Representative.

1.2 VARIATIONS WITH CODES, REGULATIONS AND STANDARDS

A. Nothing in the drawings and specifications permits Work not conforming to codes, permits or regulations. Promptly submit written notice to Project Representative of observed variations or discrepancies between the Contract documents and governing codes and regulations.

**TWANOH STATE PARK
LAGOON, SHORELINE AND STREAM RESTORATION**

- B. Appropriate modifications to the Contract documents will be made by Change Order to incorporate changes to Work resulting from code and/or regulatory requirements. Contractor assumes responsibility for Work contrary to such requirements if Work proceeds without notice.
- C. Contractor is not relieved from complying with requirements of Contract documents which may exceed, but not conflict with requirements of governing codes.

1.3 COORDINATION WITH REGULATORY AGENCIES

- A. Coordinate Work with appropriate governing or regulating authorities and agencies.
- B. Provide advance notification to proper officials of Project schedule and schedule revisions throughout Project duration, in order to allow proper scheduling of inspection visits at proper stages of Work completion.
- C. Regulation coordination is in addition to inspections conducted by Project Representative. Notify Project Representative of scheduled inspections involving outside regulating officials, to allow Project Representative to be present for inspections.

PART 2 - PRODUCTS (NOT USED)

PART 3 - EXECUTION (NOT USED)

END OF SECTION

**TWANOH STATE PARK
LAGOON, SHORELINE AND STREAM RESTORATION**

SECTION 014200 – REFERENCES

PART 1 - GENERAL

1.1 DEFINITIONS

- A. General: Basic Contract definitions are included in the General Conditions of the Contract.
- B. "Approved": When used to convey Project Representative's action on Contractor's submittals, applications, and requests, "approved" is limited to Project Representative's duties and responsibilities as stated in the General Conditions of the Contract.
- C. "Directed": A command or instruction by Project Representative. Other terms including "requested," "authorized," "selected," "required," and "permitted" have the same meaning as "directed."
- D. "Indicated": Requirements expressed by graphic representations or in written form on Drawings, in Specifications, and in other Contract Documents. Other terms including "shown," "noted," "scheduled," and "specified" have the same meaning as "indicated."
- E. "Regulations": Laws, ordinances, statutes, and lawful orders issued by authorities having jurisdiction, and rules, conventions, and agreements within the construction industry that control performance of the Work.
- F. "Furnish": Supply and deliver to Project site, ready for unloading, unpacking, assembly, installation, and similar operations.
- G. "Install": Operations at Project site including unloading, temporarily storing, unpacking, assembling, erecting, placing, anchoring, applying, working to dimension, finishing, curing, protecting, cleaning, and similar operations.
- H. "Provide": Furnish and install, complete and ready for the intended use.
- I. "Project Engineer", "Project Architect", "Engineer", and "Architect" are interchangeable terms.
- J. Project Representative and Owners Representative are interchangeable terms.
- K. "As-built Drawings": Drawings done by the Contractor in the field showing changes to the Work.
- L. "Record Drawings": Drawings prepared based on the information on the As-built Drawings.
- M. "Shop Drawings": Drawings done by the Manufacturer that are stamped and signed by licensed structural engineer in the State of Washington.

**TWANOH STATE PARK
LAGOON, SHORELINE AND STREAM RESTORATION**

1.2 GENERAL

- A. Applicable standards of the construction industry have the same force and effect (and are made a part of the Contract Documents by reference) as if directly copied or bound herein.

1.3 PUBLICATION DATES

- A. Where compliance with an industry standard is required, comply with the standard in effect on Bid Date.

1.4 ABBREVIATIONS AND NAMES

- A. The following acronyms or abbreviations, referenced in the Contract documents, are defined to mean the associated name. Applicable standards include, but are not limited to the following:

1.	AASHTO	American Association of State Highway & Transportation Officials
2.	ACI	American Concrete Institute
3.	AGA	American Gas Association
4.	AI	Asphalt Institute
5.	AIA	American Institute of Architects (The)
6.	AISC	American Institute of Steel Construction, Inc.
7.	AISI	American Iron and Steel Institute
8.	AITC	American Institute of Timber Construction
9.	ANSI	American National Standards Institute
10.	APA	Engineered Wood Association (The)
11.	APWA	American Public Works Association
12.	ASME	American Society of Mechanical Engineers
13.	ASTM	American Society for Testing and Materials International
14.	AWPA	American Wood Protection Association
15.	AWS	American Welding Society
16.	AWWA	American Water Works Association
17.	CRSI	Concrete Reinforcing Steel Institute
18.	EPA	Environmental Protection Agency
19.	HPVA	Hardwood Plywood and Veneer Association
20.	IBC	International Building Code
21.	IEEE	Institute of Electrical & Electronics Engineers, Inc. (The)
22.	IES	Illuminating Engineering Society of North America
23.	LPI	Lighting Protection Institute
24.	MCAA	Mechanical Contractors Association of America, Inc.
25.	NIST	National Institute of Standards and Technology
26.	NCMA	National Concrete Masonry Association
27.	NEC	National Electrical Code
28.	NECA	National Electrical Contractors Association, Inc.
29.	NFPA	National Fire Protection Association
30.	NHLA	National Hardwood Lumber Association
31.	NSF	National Sanitation Foundation International
32.	OSHA	Occupational Safety & Health Administration
33.	PCA	Portland Cement Association, (The)
34.	SEPA	State Environmental Policy Act

**TWANOH STATE PARK
LAGOON, SHORELINE AND STREAM RESTORATION**

- | | | |
|-----|--------------|---|
| 35. | UL | Underwriters Laboratories, Inc. |
| 36. | UPC | Uniform Plumbing Code |
| 37. | WCLIB | West Coast Lumber Inspection Bureau (Grading Rules) |
| 38. | WRI | Wire Reinforcement Institute |
| 39. | WSDOE or ECY | Washington State Department of Ecology |
| 40. | WSDOH or DOH | Washington State Department of Health |
| 41. | WSDOT | Washington State Department of Transportation |
| 42. | WSPRC | Washington State Parks and Recreation Commission |
| 43. | WWPA | Western Wood Products Association (Grading Rules) |

PART 2 – PRODUCTS (NOT USED)

PART 3 – EXECUTION (NOT USED)

END OF SECTION

**TWANOH STATE PARK
LAGOON, SHORELINE AND STREAM RESTORATION**

SECTION 015000 – TEMPORARY FACILITIES AND CONTROLS

PART 1 - GENERAL

1.1 PROTECTION OF PROPERTY AND EXISTING FACILITIES

- A. Provide protections necessary to prevent damage to park property and facilities.
- B. Only rubber-tired equipment are permitted to operate on paved park roads.
- C. Protect existing trees and other vegetation indicated to remain in place against cutting, breaking or skinning of roots, skinning and bruising of bark, or smothering of trees by stockpiling materials within dripline. Provide necessary temporary guards to protect trees and vegetation to remain in place.
- D. Make every effort to minimize damage and cutting major tree roots during excavation operations. Provide protection for larger tree roots exposed or cut during excavation operations.

1.2 ENVIRONMENTAL PROTECTIONS

- A. Scope:
 - 1. Provide labor, materials, equipment and perform Work required for protection of environment during and as a result of construction operations under contract.
- B. Applicable Regulations:
 - 1. Comply with applicable federal, state and local laws and regulations concerning environmental pollution control and abatement, and specific requirements elsewhere in specifications and drawings to prevent and provide for control of environmental pollution.
- C. Protection of Land Resources:
 - 1. Give special attention to the effect of Contractor's operations upon surroundings. Take special care to maintain natural surroundings undamaged and conduct Work in compliance with following requirements:
 - a. When Work is completed, remove storage and other Contractor buildings and facilities, and sites restored to a neat and presentable condition appropriate to surrounding landscape, unless otherwise specified. Remove debris resulting from Contractor's operation.
 - b. Store petroleum products, industrial chemicals and similar toxic or volatile materials in durable containers approved by the Authority Having Jurisdiction and located in areas where accidental spillage will not enter water. Store substantial quantities of materials in an area surrounded by containment dikes of sufficient capacity to contain an aggregate capacity of tanks.

**TWANOH STATE PARK
LAGOON, SHORELINE AND STREAM RESTORATION**

D. Protection and Restoration of Property:

1. Preserve public and private property, monuments, power and telephone lines, other utilities, prevention of damage to natural environment, etc., insofar as they may be endangered by Work.
2. When or where any direct or indirect damage or injury is done to public or private property by or on account of any act, omission, neglect or misconduct in execution of Work, or in consequence of non-execution of Contractor, restore, or have restored at Contractor's expense, such property to a condition similar and equal to that existing before such damage or injury was done, by repairing, rebuilding, or otherwise restoring same, or make good damage or injury in some other manner acceptable to Project Representative.

E. Protection of Water Resources:

1. Perform Work not to create conditions injurious to fish or to their habitat, or which would make water unsuitable for private, municipal, or industrial use.
2. Take special measures to prevent chemicals, fuels, oils, grease, bituminous materials, waste washings, herbicides, insecticides, lime, wet concrete, cement, silt or organic or other deleterious material from entering waterways.
3. Dispose of offsite, in a lawful manner conforming to applicable local, state and federal laws wastes, effluents, trash, garbage, oil, grease, chemicals, cement, bitumen, etc., petroleum, and chemical products or wastes containing such products. Furnish Owner with documentation showing compliance with this requirement.
4. Conform to applicable local, state and federal laws for disposal of effluents. Dispose of waters used to wash down equipment in a manner to prevent their entry into a waterway. If waste material is dumped in unauthorized areas, remove material and restore area to condition of adjacent, undisturbed area. If necessary, excavate contaminated ground and disposed of as directed by Project Representative and replace with suitable compacted fill material with surface restored to original condition.

F. Dust Control:

1. Dust control is required on roads used by Contractor. Maintain excavations, embankments, stockpiles, roads, plant sites, waste areas, borrow areas and other Work areas within or without the Project boundaries free from dust which would cause a hazard or nuisance to others. Provide approved, temporary methods of stabilization consisting of sprinkling, chemical treatment, light bituminous treatment or equal methods to control dust. If sprinkling is used, sprinkling must be repeated at intervals to keep disturbed areas at least damp.

G. Temporary Water Pollution/Erosion Controls:

1. Provide for prevention, control and abatement of soil erosion and water pollution within the limits of Project, to prevent and/or minimize damage to adjacent bodies of water and Work itself.
2. Coordinate temporary soil erosion/water pollution control measures with permanent drainage and erosion control Work to ensure effective and continuous controls are maintained throughout Project life.

**TWANOHO STATE PARK
LAGOON, SHORELINE AND STREAM RESTORATION**

3. Develop a written spill prevention and response plan for construction activities adjacent to/and over any surface waters and/or wetlands. "Adjacent" means within 150' as measured on a horizontal plane. Plan addresses:
 - a. Narrative description of the proposed construction methods, materials, and equipment to be used for Work
 - b. Assessment and listing of hazardous materials and/or potential contaminants that could be released during execution of Work
 - c. SDS sheets with cleanup instructions for potential contaminants
 - d. Spill response/cleanup materials and instructions for use
 - e. Procedures and precautions to prevent spills
 - f. Spill response training for on-site personnel, including the location of the containment and cleanup materials at site
 - g. Emergency notification in case of a spill or release. Park Manager and Project Representative must be included on the list of notified.
4. Comply with applicable codes and ordinances for spill prevention and response plan and submit a copy to Project Representative before commencing Work adjacent to or over any waters and/or wetlands.

H. Emergency Spill Response Notification

1. Under state law, Ecology must be notified when any amount of regulated waste or hazardous material that poses an imminent threat to life, health, or the environment is released to the air, land, or water, or whenever oil is spilled on land or to waters of the state. The spiller is always responsible for reporting a spill. Failure to report a spill in a timely manner may result in enforcement actions. If you are not responsible for a spill, making the initial notification does not make you liable. However, please consult with Ecology's response team before attempting any type of response or cleanup. Also notify Park Manager and Project Representative.
2. If oil or hazardous materials are spilled to state waters, the spiller must notify both federal and state spill response agencies. The federal agency is the National Response Center at 1-800-424-8802. For state notification, call the Washington Emergency Management Division (EMD) at 1-800-258-5990 or 1-800-OILS-911 AND the appropriate Ecology regional office for your county (see numbers below). An Ecology spill responder will normally call reporting party back to gather more information. The agency will then determine its response actions. Also notify Park Manager and Project Representative.
3. Ecology Regional Spill Reporting Numbers:
 - a. Southwest Regional Office: (360) 407-6300 (Clallam, Clark, Cowlitz, Grays Harbor, Jefferson, Kitsap, Lewis, Mason, Pacific, Pierce, Skamania, Thurston, and Wahkiakum counties)
TDD: Washington Relay Service 711 or (800) 833-6388.

1.3 PARK TRAFFIC/PEDESTRIAN CONTROLS

- A. Properly warn the public of construction equipment and activities, open trenches, and/or other unsafe conditions by providing all necessary warning equipment. Equipment includes warning signs, barricades, fencing, flashing lights and traffic control personnel (flaggers).

**TWANOH STATE PARK
LAGOON, SHORELINE AND STREAM RESTORATION**

- B. Conduct operations with the least possible obstruction and inconvenience to the public in accordance with appropriate Section(s) of the WSDOT "Standard Specifications".

1.4 PROTECTION OF WORK

- A. Protect Work, materials, and equipment against damage, weather conditions, or other hazards. Equipment, Work or materials found damaged or in other than new condition will be rejected by Project Representative.

1.5 REMOVAL AND REPLACEMENT OF STATE-OWNED ITEMS

- A. Should any state-owned items, such as signs, bumper blocks, or related items, interfere with the proper construction process, remove and reinstall such items to the satisfaction of Project Representative.

1.6 USE OF PARK SPACE

- A. Only in areas of park that Contract covers and only during active inclusive dates of Contract.
- B. Contractor vehicle and equipment parking only as designated by Project Representative.
- C. Contractor will be issued temporary parking passes for construction crew, vehicles and equipment, valid for the duration of the contract only.

1.7 ROADWAY CLOSURE

- A. Closure of the park is not in the best interest of the general public, only close roads being trenched while conduits, etc., are being installed, and immediately reopened for traffic. Supply necessary barricades, etc., to effectively prevent automotive traffic from entering upon any traveled way while trenches are open, unless other approved appropriate safety measures are taken.

1.8 UTILITIES

- A. Existing subsurface utilities on Project are represented on Contract Drawings to the best of the Commission's knowledge. It is Contractor's responsibility to verify existence of utilities and determine exact location and depth. Maintain use of utilities during construction through temporary connections or other measures suitable to Commission. No extra compensation will be made for removal, temporary connections, relocations, or replacement of utilities.

1.9 SERVICE OUTAGES

- A. Coordinate and schedule outages for, power, water, and sewer service connections/repairs with Park Manager, so as not to inconvenience park staff or public.

**TWANOH STATE PARK
LAGOON, SHORELINE AND STREAM RESTORATION**

1.10 SANITARY FACILITIES

- A. Provide temporary toilets, wash facilities, and drinking water for use of construction personnel. Comply with requirements of Authorities Having Jurisdiction for type, number, location, operation, and maintenance of fixtures and facilities.

PART 2 - PRODUCTS (NOT USED)

PART 3 - EXECUTION (NOT USED)

END OF SECTION

**TWANOH STATE PARK
LAGOON, SHORELINE AND STREAM RESTORATION**

SECTION 015526 – TRAFFIC CONTROL

PART 1 – GENERAL

1.1 GENERAL

- A. Provide flaggers, signs, and other traffic control devices in accordance with the Washington State Department of Transportation (WSDOT) Current Edition, Standard Specifications for Road, Bridge, and Municipal Construction and the Manual on Uniform Traffic Control Devices (MUTCD). Erect and maintain construction signs, warning signs, detour signs, and other traffic control devices necessary to warn and protect the public from injury or damage as a result of the Contractor's operations that may occur on highways, roads, drives, streets, or sidewalks and walkways. Do no work on or adjacent to the above locations until necessary signs and traffic control devices are in place.
- B. These flaggers, signs, and other traffic control devices are for the safety of the public, the Contractor's employees, and Commission's personnel and to facilitate the movement of the traveling public. They may be used for the separation or merging of public and construction traffic when in accordance with a specific approved traffic control plan.
- C. Upon failure of the Contractor to immediately provide flaggers; erect, maintain, and remove signs; or provide, erect, maintain, and remove other traffic control devices, the Commission may, without further notice to the Contractor, shut down the Contractor's activity until adjacent traffic control is implemented.
- D. Providing adequate flaggers, signs, and other traffic control devices for the protection of the work and the public at all times, regardless of whether or not the flaggers, signs, and other traffic control devices are ordered by the Project Representative, furnished by the Commission, or paid for by the Commission or by any modifications made by the Contractor. The Contractor shall be liable for injuries and damages to persons and property suffered by reason of the Contractor's operations or any negligence in connection therewith.
- E. Lane closure or diversion: advise Project Representative a minimum of two calendar days prior to implementation.

1.2 CONFORMANCE TO ESTABLISHED STANDARDS

- A. Flagging, signs, and other traffic control devices: conform to the standards established in the latest edition of the WSDOT Standard Specifications for Road, Bridge, and Municipal Construction, to the WSDOT Traffic Control Plans 1 through 18 (TC1-19) as published by WSDOT at <https://www.wsdot.wa.gov/Design/Standards/PlanSheet/Work-Zone-Typical-TCPs.htm> and to the Manual on Uniform Traffic Control Devices (MUTCD).

1.3 SUBMITTALS

- A. Submit a temporary traffic control plan for Project Representative review.

**TWANOH STATE PARK
LAGOON, SHORELINE AND STREAM RESTORATION**

- B. The Contractor shall submit a construction sequencing action plan for the Project Representative review and approval. The action shall address critical paths for construction timing to minimize road closure duration in Twanoh State Park. Construction sequencing preferences shall be addressed during the mandatory pre-bid meeting.

PART 2 – PRODUCTS

2.1 TEMPORARY FENCING

- A. The Contractor shall provide a temporary construction chain link fence as shown on the Plans. The fence shall separate the campground area from the construction site.

PART 3 – EXECUTION

3.1 CONSTRUCTION PARKING CONTROL

- A. Control vehicular parking to prevent interference with public traffic and parking, and access by emergency vehicles. Monitor parking of construction personnel's vehicles. Maintain vehicular access to and through parking areas. Prevent parking on or adjacent to access roads or in non-designated areas.

3.2 TEMPORARY FENCE MAINTENANCE

- A. Monitor temporary fences on a daily basis to ensure that access by the public is restricted to construction areas.

END OF SECTION

**TWANOH STATE PARK
LAGOON, SHORELINE AND STREAM RESTORATION**

SECTION 015639 - TEMPORARY TREE AND PLANT PROTECTION

PART 1 - GENERAL

1.1 SUMMARY

- A. This Section includes the administrative and procedural requirements for the protection of trees, shrubs, and plant material not designated for removal. Trees, shrubs, and plant material not designated for removal shall be left in place and protected from damage or injury during construction using full and adequate methods of protection in order to preserve these natural resources, ecological function, and aesthetic character of the park.

1.2 REFERENCES

A. Definitions

1. Arborist Qualifications: An Arborist approved of by the Project Representative or certified by the International Society of Arboriculture (ISA) or Association of Consulting Arborists (ASCA) and licensed in the jurisdiction where project is located.
2. Critical Root Zone (CRZ): The portion of the root system nearest the stem that is critical for the stability and vitality of the tree. The minimum CRZ is a circular area having a radius of one foot for each one inch of trunk diameter defined by measuring the trunk diameter at 4.5 feet above ground level. For example, a tree that has a diameter of 20 inches would have a CRZ with a radius of 20 feet from the base of the tree. This is a MINIMUM CRZ radius for healthy trees; the CRZ often extends beyond the dripline of the tree. A critical root zone defined by 2.5 feet radius for each 1-inch diameter is desirable for old growth, historic, and character trees as designated by the Project Representative.
3. Vegetation Protection Zone (VPZ): A defined area of any size within the project area where existing vegetation (trees, shrubs, or other plant material) is to be protected from construction impacts. The zone may be accomplished by physical barriers or other means (e.g., soil protection layers or treatments).
4. Soil Protection Zone (SPZ): A defined area of any size within the project area where sensitive native soils are to be protected from construction impacts. The zone may be accomplished by physical barriers or other means (e.g., soil protection layers, durable matting, or other treatments as specified by the Project Representative).
5. High Risk Tree: Any tree with a structural defect and/or disease that makes the tree highly prone to failure, and which has a target and may result in personal injury or property damage. A high risk tree is the same as an "Emergency Tree" as defined in WAC 352-28-005 (<https://apps.leg.wa.gov/wac/default.aspx?cite=352-28-005>)

B. Reference Standards

1. ANSI A300. Specifications for Tree, Shrub, and Other Woody Plant Management including Section 5: Management of Trees and Shrubs During Site Planning, Site Development, and Construction.
2. ANSI Z133-2012. Safety Requirements for Arboricultural Operations.

**TWANOH STATE PARK
LAGOON, SHORELINE AND STREAM RESTORATION**

3. Council of Tree and Landscape Appraisers. (2020). *Guide for Plant Appraisal*, 10th ed. International Society of Arboriculture, Champaign, Illinois.

1.3 SUBMITTALS

- A. Tree Removal and Pruning Schedule: Written schedule from project Arborist detailing scope and extent of tree removals and pruning of trees to remain that interfere with or are affected by construction.
- B. Certification: From project Arborist, certifying that trees indicated to remain have been protected during construction according to recognized standards and that trees were promptly and properly treated and repaired when damaged.
- C. Maintenance Recommendations: From project Arborist, for care and protection of trees affected by construction during and after completing the Work.

1.4 QUALITY ASSURANCE

- A. Tree Pruning Standard: Comply with ANSI A300 (Part 1), "Tree, Shrub, and Other Woody Plant Maintenance--Standard Practices (Pruning)."
- B. Construction Management Standard: Comply with ANSI A300 (Part 5): Management of Trees and Shrubs During Site Planning, Site Development, and Construction
- C. Tree Planting: Comply with ANSI A300 (Part 6) Planting and Transplanting
- D. Tree Root Protection and Management: Comply with ANSI A300 (Part 8) - 2013 Root Management Standard

PART 2 - PRODUCTS

2.1 TREE PROTECTION MATERIALS

- A. Temporary Fencing
 1. Chain link fencing panels 6 feet tall by any length up to 14 feet. Panels must be braced and must be secured to stands and weighted per manufacturers specifications.
 2. Continuous molded safety mesh 36 inches wide with clear openings no more than 1-1/2 inches x 2 inches. Orange, 40 grams per square foot, high density polyethylene with U-V inhibitor suitable for above-grade use installed around the circumference of the CRZ.
 3. Posts five-foot steel heavy-duty "T" posts, 1-3/8 inches x 1-3/8 inches x 7/64 inches with steel anchor placed at 8' intervals at or beyond the CRZ.
- A. Nylon zip straps having a minimum breaking strength of 150 lbs.

**TWANOHO STATE PARK
LAGOON, SHORELINE AND STREAM RESTORATION**

2.2 SOIL AND ROOT PROTECTION

- A. Mulch: Ground, shredded bark, or wood and bark chips, or “hog fuel” free from deleterious materials. Or new straw mulch, free from weeds, weed seeds, and foreign materials.
- B. Landscape fabric: American Excelsior Stabilenka 140, Celanese Mirafi 140, Propex 45-45, or approved equivalent geotextile.
- C. Filter Fabric: Manufacturer’s standard, nonwoven, pervious, geotextile fabric of polypropylene, nylon, or polyester fibers.
- D. Ground staples: 9 inches x 9 inches wire staples sufficient for holding landscape fabric or filter fabric in place for required time period.
- E. Ground protection mats: Construction mats or timber mats, as a temporary road surface of sufficient weight rating for the equipment being operated in the work area.

2.3 TREE TRUNK PROTECTION

- A. Where work has been approved to take place within the CRZ, tree trunk protection shall be installed vertically around tree trunk on all sides exposed to construction activity.
- B. Common wood 2 inches x 4 inches lumber, 8 feet long, without nails, other hardware, concrete residue, or other material that may be detrimental to plant health.
- A. Strapping sufficient to hold 2 x 4’s in place.

PART 3 - EXECUTION

3.1 PLANNING AND NOTIFICATION

- A. Where existing trees and other vegetation are in the area of work, or where existing trees outside the area of work have a CRZ extending into the area of work, employ methods to minimize adverse impact to the existing trees (including limbs, stems, and roots), understory vegetation and their root systems, and soils. Where VPZ are designated by the Project Representative and/or in project plans, observe protection measures set forth herein. Notify the Project Representative of any construction work within the CRZ of trees at least two (2) working days before the scheduled activity.

3.2 PREPARATION

- A. Prior to Construction: Erect tree and plant protection prior to beginning any site work. Protect trees to remain against cutting, breaking, skinning, or compaction of roots; skinning or bruising of bark; breaking of branches and foliage. Review locations, fencing, and other markings of any VPZ and CRZ for trees within the construction area with the Project Representative.
- B. Tree Removal: Trees that are scheduled for removal as part of the project should be removed before construction to prevent hazards during construction.

**TWANOH STATE PARK
LAGOON, SHORELINE AND STREAM RESTORATION**

- C. Material Storage: Do not store construction materials, debris, or excavated material inside critical root zones or vegetation protection zones.
- D. Vehicle and Foot Traffic: Designate access routes within construction area and limitations on equipment and vehicles. Designate parking on existing pavement or away from critical root zones of trees. Tree protection fencing will serve as an exclusion zone within the CRZ except for where plans stipulate work will take place within the CRZ.

3.3 CRITICAL ROOT ZONE AND VEGETATION PROTECTION ZONE DESIGNATION

- A. Temporary Fencing: Install temporary fencing around CRZ, VPZ, or SPZ of either chain link or plastic mesh as indicated by Project Representative. Maintain temporary fence during construction and remove only when construction is complete.
 - 1. For plastic mesh, line posts space at eight feet maximum. Set posts vertically to minimum 18 inches depth. Posts may be driven provided method of driving does not damage posts. Ensure that posts do not damage tree roots.
 - 2. Where plastic fence is used, secure plastic fencing to posts with nylon zip-straps, minimum three per post. Draw fence material tight and vertical. Where chain link panels are used join panels with manufacturers clamps that require tool removal.
 - 3. With Project Representative's approval, sections of tree protection fencing may be removed temporarily to allow approved short-term construction activities. Reinstall fencing immediately when construction operations permit.
- B. Tree Trunk Protection: Where required tree trunks shall be protected by placing 2 x 4 lumber around the trunk, spaced so that strapping will not come in contact with the tree bark and lumber does not damage branches. Use strapping to hold lumber in place. Secure straps without nailing into or otherwise damaging tree bark.

3.4 SOIL COMPACTION, LOSS, AND DAMAGE WITHIN THE CRITICAL ROOT ZONE

- A. Protection against soil compaction within the CRZ may include but will not be limited to the following methods:
 - 1. Application of a minimum 6-inch thick layer of mulch (or wood chips salvaged from clearing and grubbing operations) within the CRZ. Replenish mulch as necessary to maintain a 6-inch depth. Do not place mulch within 6 inches of tree trunks. Where mulch is to be removed following project completion it should be underlaid with a porous geotextile.
 - 2. Ground protection mats, such as: timber or steel planking, construction mats, 1/2 inches thick CDX grade (or better) plywood, or brush for protection of surface roots and vegetation from equipment.
 - 3. Where equipment operating within the CRZ exceeds 12,000 lbs use a 6-inch layer of mulch overlaid with ground protection mats described above.
- B. Protection of soils against erosion and loss within the critical root zone of trees may require application of mulch, wood chips, ground protection mats, or landscape fabric at the request of the Project Representative.

**TWANOHO STATE PARK
LAGOON, SHORELINE AND STREAM RESTORATION**

- C. Noxious Materials: Protect soils from damage caused by runoff or spillage of noxious materials while operating, mixing, placing, or storing construction materials and equipment; this includes washout of concrete mixing vessels, dewatering operations, equipment cleanup, maintenance, and service; ponding, erosion, or excessive wetting may incur a Stop-Work order at the discretion of the Project Representative.
- 3.5 TRENCHING, DIGGING, TUNNELING, AND GRADING WITHIN THE CRITICAL ROOT ZONE:
- A. Disturbance to soils and impacts to roots within the CRZ may require any of, and will not be limited to, the following methods, practices, and restrictions:
1. Maintain existing grade within CRZ of trees unless otherwise directed.
 - a. Lowering grades (cutting): Where existing grade is above new finish grade shown around trees, carefully excavate within CRZ to new grade. Document roots exposed in this process with photographs to be shared with project Representative.
 - b. Raising grades (filling): Where existing grade is raised within the CRZ to greater than 4 inches above existing grade these roots shall be considered damaged by smothering. Methods to increase air exchange of tree roots within these areas may be required. Examples of such methods may include and will not be limited to:
 - 1) Application of a 6 inch or thicker layer of large clean aggregate (2 inches by 4 inches or larger) covered with landscape fabric below fill material to maintain large pore space.
 - 2) Selection of a fill material with high porosity and minimal compressibility, which may include mulch. Compaction will not be required except as required by structural load requirements, to limit soil compaction.
 2. Alternative excavation methods that minimize root damage may be required. These may include but are not limited to: hand digging, horizontal boring, use of an air excavation tool, or other methods as otherwise deemed necessary by the Project Representative.
- B. Only limited intrusions into tree CRZ zones will be allowed as shown on the plans and with the approval of the Project Representative. Where trenching for utilities or irrigation is required within CRZ's of trees the following may be required:
1. No cutting of roots greater than two inches diameter. Tunnel under or around roots by drilling, auger boring, air excavation, or digging by hand.
 2. Where necessary for installation, cut roots with sharp pruning instruments flush with the edge of the trench or tunnel; do not break or chop.
 3. Avoid hitting roots with heavy equipment. Roots that are ripped by equipment should be excavated by hand, photographed, kept moist with mulch or burlap layers, and inspected by the Project Representative.
 4. Pile excavated soil outside of the CRZ of residual trees and return area to original grade upon completion of work.
 5. Cover exposed roots with soil as soon as possible or at the end of each day; the soil compacted to the original firmness only; and, watered when conditions are dry.
 6. Tree root pruning or other tree root treatments may be required as directed by the Project Representative.

**TWANOH STATE PARK
LAGOON, SHORELINE AND STREAM RESTORATION**

7. Root painting is not permitted.

3.6 STEM AND BRANCH PRUNING:

- A. Any unnecessary cutting, breaking, skinning, or bruising of bark; breaking of branches and foliage; damage or clearing of vegetation in the work area will not be permitted. Where permitted, stem and branch pruning must follow ANSI A300 Standards (including Part 1 and Part 5).
- B. Temporarily tie-up of low limbs is permitted where designated by the project representative.
- C. All final pruning cuts shall be made in branch tissue close to the trunk or parent limb, without cutting into the branch bark ridge or branch collar and without leaving a stub. Flush cuts to the tree trunk that remove the branch collar are unacceptable. Flush cuts result in a larger wound and expose trunk tissues to the possibility of decay.
- D. All significant tree pruning must have prior approval of Project Representative. An approved Arborist may be required, at the Contractors expense, for extensive or technically challenging pruning activities. Such requirements will be made explicit to the Contractor prior to the start of work.
- E. Only proper branch pruning techniques will be accepted. Improperly pruned trees could be irreparably damaged and are subject to section 3.7 DAMAGE TO TREES AND TREE REPLACEMENT.

3.7 DAMAGE TO TREES AND TREE REPLACEMENT:

- A. Should any tree or vegetation designated to remain be damaged in the course of construction activities immediately notify the Project Representative for inspection and direction for remedy.
- B. Remedies for damage will, at the Owner's discretion, require removal and disposal of the damaged tree(s) and be one of the following, at the discretion of the Project Representative.
 1. Compensate the Owner in cash or as a credit to the contract for up to the full value of the damaged tree, as appraised by an ISA certified Arborist according to the latest edition of the "Guide for Plant Appraisal".
 2. Replace each damaged tree under 6 inches diameter at breast height measurement with one replacement tree of 1-3/4 inches caliper measure. Replace each damaged tree over 6 inches diameter at breast height measurement with one replacement tree of 1-3/4 inches caliper measure for each 6 inches of diameter at breast height measure of the damaged tree. The new trees may or may not be the same species, at the discretion of the Project Representative. Select nursery stock, plant, and maintain as specified in Section 1.4 QUALITY ASSURANCE.
 3. For identified old-growth trees specified to remain, the Project Representative may be provided alternative remediation requirements from Parks Stewardship staff above and beyond requirements of 3.7.B.1 and 3.7.B.2.
- C. Notify Project Representative in any case where construction called for in the contract documents cannot be completed without damage to trees identified to remain. Approval of the Project

**TWANOHO STATE PARK
LAGOON, SHORELINE AND STREAM RESTORATION**

Representative is required prior to beginning construction described in the contract documents that might damage a tree designated to remain. Any tree designated to remain which is damaged without Project Representative's written approval, even if damage is necessary to complete the work, will subject the Contractor to remedies described in section 3.7 B above.

END OF SECTION

**TWANOH STATE PARK
LAGOON, SHORELINE AND STREAM RESTORATION**

SECTION 016000 – PRODUCT REQUIREMENTS

PART 1 - GENERAL

1.1 IMPLIED/INCIDENTAL MATERIALS

- A. Minor materials required for proper Project completion although not specifically mentioned or shown in Contract documents, are part of materials to be provided by Contractor as a part of Contract and are considered incidental to the total cost of Project. No additional compensation is due to the Contractor for providing such items.

1.2 QUALITY OF MATERIALS

- A. Materials are to be new, free from defects, and of quality specified in the drawings and specifications.
- B. Select and provide materials to ensure satisfactory operation and rated life in prevailing environmental conditions were installed.
- C. Same make and quality throughout the entire job, for each type. Furnish materials of latest standard design products of manufacturers regularly engaged in their production.

1.3 SPECIFIED MATERIALS

- A. Drawings and specifications generally reference only one make and model for each item of material or equipment required. This is not intended to be restrictive but indicates the standard of quality, design, and features required.
- B. Specified product is the basis of design regarding physical size, strength, and performance. Products named indicate minimum acceptable product and are "or equal" unless noted otherwise.

1.4 BUY AMERICA PROVISIONS FOR INFRASTRUCTURE

- A. Per 2 CFR Part 184, none of the funds provided under this award may be used for a project for infrastructure unless:
 - 1. All iron and steel used in the project are produced in the United States. This means all manufacturing processes, from the initial melting stage through the application of coatings, occurred in the United States,
 - 2. All manufactured products used in the project are produced in the United States. This means the manufactured product was manufactured in the United States, and the cost of the components of the manufactured product that are mined, produced, or manufactured in the United States is greater than 55 percent of the total cost of all components of the manufactured product, unless another standard for determining the minimum amount of domestic content of the manufactured product has been established under applicable law or regulation, and

**TWANOH STATE PARK
LAGOON, SHORELINE AND STREAM RESTORATION**

3. All construction materials are manufactured in the United States. This means that all manufacturing processes for the construction material occurred in the United States. For construction material standards, see 2 CFR §184.6.

- B. This Buy America preference only applies to articles, materials, and supplies consumed in, incorporated into, or affixed to an infrastructure project. As such, it does not apply to tools, equipment, and supplies, such as temporary scaffolding, brought to the construction site and removed at or before the completion of the infrastructure project. Nor does a Buy America preference apply to equipment and furnishings, such as movable chairs, desks, and portable computer equipment, used at or within the finished infrastructure project but are not an integral part of the structure or permanently affixed to the infrastructure project.

- C. There may be instances where an award qualifies, in whole or in part, for an existing DOI general applicability waiver. Recipients are responsible for determining if an approved waiver applies to their project. A list of active waivers is available at: www.doi.gov/grants/BuyAmerica/GeneralApplicabilityWaivers. As new waivers may be issued at any time, we recommend Recipients frequently check this web page through the life of their project. If an active waiver applies to the project, the Recipient must retain a record of the applicable waiver per 2 CFR §200.334 recordkeeping requirements. If the specific financial assistance agreement, infrastructure project, or non-domestic materials meets the criteria of an existing general applicability waiver within the limitations defined within the waiver, the Recipient does not need to request a separate waiver for non-domestic materials.

- D. When necessary, recipients may apply for, and the DOI may grant, a waiver from these requirements, subject to review by the Made in America Office. Per 2 CFR §184.7, the DOI may waive the application of the domestic content procurement preference in any case in which it is determined that one of the below circumstances applies:
 1. Non-availability Waiver: the types of iron, steel, manufactured products, or construction materials are not produced in the United States in sufficient and reasonably available quantities or of a satisfactory quality,
 2. Unreasonable Cost Waiver: the inclusion of iron, steel, manufactured products, or construction materials produced in the United States will increase the cost of the overall project by more than 25 percent, or
 3. Public Interest Waiver: applying the domestic content procurement preference would be inconsistent with the public interest.
 4. If a general applicability waiver does not already apply, and the Recipient believes that one of the above circumstances applies to an award, the Recipient may submit a request to waive the application of the domestic content procurement preference.

- E. Recipients must submit all waiver requests to the Service in writing. Email all waiver requests to fwhqfasupport@fws.gov. Please use the subject line: "Buy America Waiver Request". Include the following information with each waiver request:

**TWANOHO STATE PARK
LAGOON, SHORELINE AND STREAM RESTORATION**

1. Type of waiver requested (non-availability, unreasonable cost, or public interest)
 2. Requesting entity name and Unique Entity Identifier (UEI)
 3. Federal awarding agency: U.S. Fish and Wildlife Service, DOI
 4. Awarding program Assistance Listing number and title (Notice of Award, Block 2)
 5. Project title (Notice of Award, Block 8)
 6. Federal Award Identification Number (Notice of Award, Block 4)
 7. Federal award amount (Notice of Award, Block 11)
 8. Total estimated infrastructure costs, to the extent known
 9. Infrastructure project description and location, to the extent known
 10. List of iron or steel item(s), manufactured goods, and construction material(s) proposed to be waived from the Buy America requirements. Include the name, cost, country of origin, if known, and relevant PSC or NAICS code for each (see <https://psctool.us/> and <https://www.census.gov/naics/>).
 11. A certification that the Recipient made a good faith effort to solicit bids for domestic products supported by terms included in requests for proposals, contracts, and nonproprietary communications with the prime contractor.
 12. A statement of waiver justification, including a description of the Recipient's efforts (e.g., market research, industry outreach) to avoid the need for a waiver. Such a justification may cite, if applicable, the absence of any Buy America-compliant bids received in response to a solicitation. For market research conducted, provide details on when it was conducted, and the sources and methods used.
 13. Anticipated impact if no waiver is issued.
 14. Note: Do not include any Privacy Act information, sensitive data, or proprietary information with the waiver request.
- F. The Department will post waiver requests to www.doi.gov/grants/buyamerica for the required 15-day public comment period. The Made in America Office will also review all waiver requests. The Department will post approved waivers at www.doi.gov/grants/BuyAmerica/ApprovedWaivers. The Service will notify Recipients of waiver request determinations by email. Waivers may be granted after an award has been issued. However, an approved waiver will not retroactively apply to expenditures already incurred under the award before the effective date of the waiver. Any such expenditures are subject to the Buy America preferences for infrastructure.

1.5 SUBSTITUTIONS

- A. Substitutions for Cause: Submit requests for substitution immediately on discovery of need for change, but not later than 15 days prior to time required for preparation and review of related submittals.
1. Conditions: Project Representative will consider Contractor's request for substitution when the following conditions are satisfied:
 - a. Requested substitution is consistent with Contract Documents and will produce indicated results.

**TWANOH STATE PARK
LAGOON, SHORELINE AND STREAM RESTORATION**

- b. Requested substitution provides sustainable design characteristics that specified product provided.
 - c. Requested substitution will not adversely affect Contractor's construction schedule.
 - d. Requested substitution has received necessary approvals of Authorities Having Jurisdiction.
 - e. Requested substitution is compatible with other portions of Work.
 - f. Requested substitution has been coordinated with other portions of Work.
 - g. Requested substitution provides specified warranty.
 - h. If requested substitution involves more than one contractor, requested substitution has been coordinated with other portions of Work, is uniform and consistent, is compatible with other products, and is acceptable to all contractors involved.
- B. Substitutions for Convenience: Project Representative will consider requests for substitution if received within 15 days after the Notice to Proceed.
- 1. Conditions: Project Representative will consider Contractor's request for substitution when the following conditions are satisfied:
 - a. Requested substitution offers Owner a substantial advantage in cost, time, energy conservation, or other considerations, after deducting additional responsibilities Owner must assume. Owner's additional responsibilities may include compensation to Engineer for redesign and evaluation services, increased cost of other construction by Owner, and similar considerations.
 - b. Requested substitution does not require extensive revisions to Contract Documents.
 - c. Requested substitution is consistent with Contract Documents and will produce indicated results.
 - d. Requested substitution provides sustainable design characteristics that specified product provided.
 - e. Requested substitution will not adversely affect Contractor's construction schedule.
 - f. Requested substitution has received necessary approvals of Authorities Having Jurisdiction.
 - g. Requested substitution is compatible with other portions of Work.
 - h. Requested substitution has been coordinated with other portions of Work.
 - i. Requested substitution provides specified warranty.
 - j. If requested substitution involves more than one contractor, requested substitution has been coordinated with other portions of Work, is uniform and consistent, is compatible with other products, and is acceptable to all contractors involved.
- C. Any proposed substitution, or "or-equal" product, must comply with the Buy America Provisions for Infrastructure in Paragraph 1.4.

1.6 SUBSTITUTION OF MATERIALS ("OR EQUAL")

- A. Proposed equipment to be considered "or equal" will necessitate written approval by the Engineer prior to substitution.
- B. On requests for substitution of materials clearly define and describe proposed substitute.
- C. Accompany requests by complete specifications, samples, records of performance, certified test reports, and such other information as the Engineer may request to evaluate the substitute product.

**TWANOHO STATE PARK
LAGOON, SHORELINE AND STREAM RESTORATION**

- D. Contractor is responsible for a substitute item suiting the installation requirements and for additional costs incurred as a result of substitution.
- E. Final decisions regarding quality and suitability of proposed substitutions rests solely with Engineer and will be based on information submitted.

1.7 TECHNICAL DATA

- A. Technical data and information contained herein relies entirely on tests and ratings provided by manufacturers who are solely responsible for their accuracy. Project Representative, by use of this information in no way implies that Project Representative has tested or otherwise verified the results of published manufacturer's information.

1.8 DELIVERY, STORAGE AND HANDLING

- A. Transport products by methods to avoid product damage. Only deliver products to the site that are undamaged and free from defects.
- B. Provide proper equipment and personnel to handle and transport materials/products to the Project sites safely and undamaged.
- C. Promptly inspect material to assure that products comply with Contract requirements, quantities are correct, and products are undamaged.
- D. Store and/or stockpile materials and products only in areas of park designated and approved by Project Representative prior to delivery.
- E. Arrange storage to provide easy access for inspections. Original product labels, certifications, stamps, etc. to be intact and readily visible for inspection purposes.

PART 2 - PRODUCTS (NOT USED)

PART 3 - EXECUTION (NOT USED)

END OF SECTION

**TWANOH STATE PARK
LAGOON, SHORELINE AND STREAM RESTORATION**

SECTION 017419 - CONSTRUCTION WASTE MANAGEMENT AND DISPOSAL

PART 1 - GENERAL (NOT USED)

PART 2 - PRODUCTS (NOT USED)

PART 3 - EXECUTION

3.1 DISPOSAL OF WASTE

- A. General: Except for items or materials to be salvaged, recycled, or otherwise reused, remove waste materials from Project site and legally dispose of them in a landfill or incinerator acceptable to Authorities Having Jurisdiction.
 - 1. Except as otherwise specified, do not allow waste materials that are to be disposed of accumulate on-site.
 - 2. Remove and transport debris in a manner that will prevent spillage on adjacent surfaces and areas.
- B. Waste and debris removed from the worksite and not specified for reuse becomes the responsibility of the Contractor and disposed of off park property in areas authorized by the applicable county and/or state agencies and in accordance with current rules and regulations governing the disposal of solid waste. Disposal fees and sundry charges are paid by the Contractor and are incidental to the contract.
- C. Burning: Do not burn waste materials.
- D. Disposal: Remove waste materials from Owner's property and legally dispose of them.

END OF SECTION

TWANOH STATE PARK
LAGOON, SHORELINE AND STREAM RESTORATION

SECTION 017700 – CLOSEOUT PROCEDURES

PART 1 - GENERAL

1.1 OPERATING AND MAINTENANCE (O&M) INSTRUCTION MANUAL

- A. Final payment will be held to no more than 95 percent completion percentage until receipt of the O & M Instruction Manuals. Payment for Contract closeout item will be made after receipt and approval of the manuals by the Project Representative. Have O & M Instruction Manuals prepared before final payment. Lack of O & M Instruction Manuals will not be a cause for Contract extensions.
- B. Furnish three (3) complete hard copy sets of binders and one (1) Electronic PDF copy on a storage device containing the following data for each mechanical, pumping, electrical equipment, major hardware, and plumbing installation or provided on this Project:
 - 1. Installation instructions
 - 2. Operating instructions (start-up and shut-down)
 - 3. Maintenance instructions, including trouble shooting guide
 - 4. Electrical schematics
 - 5. Illustrated parts breakdown and code (if available)
 - 6. Parts list (complete)
 - 7. Technical manuals
 - 8. Provide a complete list of manufacturer's sales offices, or suppliers of major parts used on this Project, including their business address and telephone number, for the Park Manager's use when maintaining/repairing the system. Major parts are defined as other than miscellaneous plumbing, wire, piping fittings, etc.
 - 9. List of subcontractors contact information, and specific items of work performed by them.
 - 10. Tab binders and clearly mark all information contained.
- C. Affix to walls, panels, boxes or at other locations, the following data sealed in heavy plastic:
 - 1. Operating instructions (start-up and shut-down)
 - 2. Electrical schematics
- D. Operating instructions refer to designated parts of each particular installation as necessary and tag such parts with permanent markers as directed by Project Representative. This includes operational equipment.

1.2 AS-BUILTS

- A. Before final acceptance of Project, furnish Project Representative "As-Builts" which shows as-built locations and dimensions of major items constructed. Include locations and elevations of existing utilities encountered during excavation. Show location of pipes, manholes, buildings, structures, etc. by field measurements consisting of at least two (2) ties to permanent surface objects such as hydrants, buildings, etc.

TWANOH STATE PARK
LAGOON, SHORELINE AND STREAM RESTORATION

- B. Final payment: No more than 95 percent until As-Built Drawings received. Payment made after receipt and acceptance of drawings by Project Representative. Lack of As-Built Drawings will not be a cause for contract extensions.

1.3 SPECIAL TOOLS

- A. Deliver special tools required for maintenance and adjustment of equipment to Project Representative upon completion and before final acceptance of Project.

1.4 SPARE MATERIALS AND PARTS

- A. Before final acceptance, deliver spare materials, parts and other similar items to storage locations specified by Project Representative.

1.5 CERTIFICATES AND PERMITS

- A. Submit signed original certificates of compliance and final approval from Authorities Having Jurisdiction.

1.6 OUTSTANDING DOCUMENTS

- A. Expedite and submit outstanding administrative documents including outstanding cost proposals, Change Orders, etc.

1.7 PRIOR OCCUPANCY

- A. Reference General Conditions.
- B. Commission has the right to occupy completed portions of Project prior to final acceptance, and such occupation is not an acceptance of Project. Prior to occupancy, Project Representative and Contractor mutually agree to a date for prior occupancy; the area to be occupied; that occupancy is commencing within the requirements of applicable codes and ordinances; that endorsements from insurance companies, as necessary to maintain full insurance of Project regardless of prior occupancy, have been obtained; and that other necessary provisions are completed.
- C. The Project Representative will inspect areas designated for prior occupancy and issue a letter of acceptance or provide a list of deficiencies to be corrected to Contractor. Correct deficiencies prior to date of occupancy.

1.8 SUBSTANTIAL COMPLETION

- A. Reference General Conditions.
- B. Notify Project Representative in writing a minimum of seven (7) days in advance of the scheduled date of completion. Project Representative will conduct a "pre-final" inspection and formulate a final punchlist of Work items to be completed prior to final inspection. Project

TWANOH STATE PARK
LAGOON, SHORELINE AND STREAM RESTORATION

Representative will establish the date of substantial completion based on pre-final inspection findings. Following this inspection, Project Representative will either issue notice of substantial completion or advise the Contractor of deficient items which must be corrected prior to issuance of substantial completion.

1.9 DAMAGE TO FACILITIES, ROADS, VEGETATION OR PROPERTY

- A. During the course of construction, should any park facility be damaged by the Contractor's actions, operations or neglect, repair any such damages to their original condition, as acceptable to the Project Representative, at no cost to the Commission.
- B. Repair, restore or replace any park roads, vegetation or property damaged by the Contractor to the original condition at the time construction began. Repair or replace trees and vegetation indicated to remain, which has been damaged by construction operations, in a manner acceptable to the Project Representative.

1.10 FINAL CLEAN-UP

- A. Upon completion of the Work and prior to final inspection and acceptance, clean up the entire construction site and all grounds occupied by the Contractor in connection with the Work.
- B. Fine graded, rake clean and smooth all worksites and disturbed areas. Remove from the park rubbish, surplus and discarded materials, falsework, temporary structures, equipment, and debris.
- C. Leave all phases of the Project clean and ready for public use prior to final acceptance.
- D. Inspect all materials and surfaces for damage, scratches, marring, untreated ends of sawcuts, etc. and repair to original or intended condition.

1.11 FINAL INSPECTION AND ACCEPTANCE

- A. Reference General Conditions.
- B. Notify Project Representative in writing when Work, including punchlist items, has been completed.
- C. Project Representative will schedule and conduct a final inspection to verify that outstanding Work items are complete.
- D. Owner will establish the date of final acceptance based on the results of final inspection. Complete/correct any items identified as outstanding during final inspection prior to final acceptance of Project.

PART 2 - PRODUCTS (NOT USED)

PART 3 - EXECUTION (NOT USED)

TWANOH STATE PARK
LAGOON, SHORELINE AND STREAM RESTORATION

END OF SECTION

**TWANOH STATE PARK
LAGOON, SHORELINE AND STREAM RESTORATION**

SECTION 024113 - SELECTIVE SITE DEMOLITION

PART 1 - GENERAL

1.1 SUMMARY

- A. This section specifies requirements for:
 - 1. Demolition, removal, transport and disposal of concrete bulkhead as identified on the Contract Plans and Specifications, or identified by the Owner's representative.

1.2 ACTION SUBMITTALS

- A. Traffic Control Plan: Submit a Traffic Control Plan for directing transport of removed materials along Twanoh Park roads onto Highway 106. The plan shall be approved by the Owner prior to proceeding with any disruption to existing facilities. The following conditions shall be met when developing the Traffic Control Plan:
 - 1. Provision for keeping the Park operational on the weekends; this includes keeping the Park free of construction debris on the weekend and active construction areas fenced off.

1.3 FIELD CONDITIONS

- A. Notify Engineer of discrepancies between existing conditions and Plans before proceeding with selective demolition. Locations for power and telephone lines will require verification by local Utilities.

PART 2 - PRODUCTS

2.1 PERFORMANCE REQUIREMENTS

- A. Regulatory Requirements: Comply with hauling and disposal regulations of authorities having jurisdiction. Use the [WSDOT Standard Specifications](#) Section 2-01.2, Section 2-02.3, and Section 2-03.3(7) that address the reuse and disposal of solid wastes during construction.

PART 3 - EXECUTION

3.1 EXAMINATION

- A. Verify that any utilities have been located and identified before starting selective demolition operations.

**TWANOHO STATE PARK
LAGOON, SHORELINE AND STREAM RESTORATION**

3.2 PREPARATION

- A. Contractor shall be responsible for contacting Utilities to arrange location services.
- B. Site Access and Temporary Controls: Conduct selective demolition and debris-removal operations to ensure minimum interference with roads and other adjacent occupied and used facilities.
- C. Temporary Facilities: Provide temporary barricades and other protection required to prevent injury to people and damage to adjacent buildings and facilities to remain.
- D. Temporary Shoring: Provide and maintain shoring, bracing, and structural supports as required to preserve stability and prevent movement, settlement, or collapse of construction to remain, and to prevent unexpected or uncontrolled movement or collapse of construction being demolished.

3.3 SELECTIVE DEMOLITION

- A. General: Demolish and remove existing construction only to the extent required by new construction and as indicated on Plans.
- B. Footbridge: Footbridge and abutments shall be removed as required for performance of construction.
- C. Concrete Bulkhead: Concrete Bulkhead shall be removed as required for performance of construction.

3.4 DISPOSAL OF DEMOLISHED MATERIALS

- A. General: Except for items or materials indicated to be, salvaged, reinstalled, or otherwise indicated to remain Owner's property, remove demolished materials from Project site and legally dispose of them in an EPA-approved landfill or recycling facility.
 - 1. Do not allow demolished materials to accumulate on-site.
 - 2. Remove and transport debris in a manner that will prevent spillage on adjacent surfaces and areas.
- B. Disposal: Transport demolished materials off Owner's property and legally dispose of them.
 - 1. Dispose of footbridge materials at an approved recycling facility.
 - 2. Dispose of concrete bulkhead at an approved recycling facility.

3.5 CLEANING

- A. Clean adjacent structures and improvements of dust, dirt, and debris caused by selective demolition operations. Return adjacent areas to condition existing before selective demolition operations began.

**TWANOHO STATE PARK
LAGOON, SHORELINE AND STREAM RESTORATION**

END OF SECTION

**TWANOH STATE PARK
LAGOON, SHORELINE AND STREAM RESTORATION**

SECTION 100000 – PROVIDE FOOTBRIDGE, LARGE WOODY DEBRIS, AND BEACH GRAVEL

PART 1 - GENERAL

1.1 SCOPE

- A. The Contractor will be responsible for purchasing and arranging the delivery of the footbridge and abutments, large woody debris and gravel to be installed at the Twanoh State Park site. Footbridge specifications and component features are shown in the structural notes in the Plan set.

PART 2 - PRODUCTS

2.1 FOOTBRIDGE

- A. This item consists of a glue laminated stringer bridge 50-feet long with a 6-foot-wide concrete decking and abutments. The Contractor shall purchase and supply the footbridge to the Work site with all appurtenances as described in the structural drawings shown in the Plan set. The abutments shall be precast or poured-in-place to the elevations as shown in the Plan set. Also includes the access ramp, abutment base course, railing and backfill as depicted on the Plans. The Contractor must coordinate the order of the described footbridge with the Owner and Engineer.

2.2 LARGE WOODY DEBRIS (LWD)

- A. These items consist of 107 pieces of LWD 24-inches in diameter and 15-feet long and 48 pieces of LWD 24-inches in diameter and 20-feet long with rootwads. The LWD shall be douglas fir species and of sound condition. The Contractor shall purchase and supply the LWD to the Work site. The Contractor must coordinate the order of the described LWD with the Owner and Engineer. The Engineer must inspect and approve LWD prior to delivery on site.

2.3 BEACH GRAVEL

- A. This item consists of washed gravel composed of the following mix:
- B. Gravel (624 CY total) mix is ~156 CY of sand to 1-inch diameter, ~156 CY of 1-inch diameter to 3-inches diameter, ~156 CY of 3-inches diameter to 5-inches diameter, and ~156 CY of 5-inches diameter to 8-inches diameter. All gravel material is to be evenly mixed for each size distribution. The Engineer must inspect and approve gravel prior to delivery on site.

**TWANOH STATE PARK
LAGOON, SHORELINE AND STREAM RESTORATION**

PART 3 – EXECUTION

3.1 EXAMINATION

A. Confirm footbridge purchase and specifications and expected delivery date with Owner and Engineer. Contractor shall review structural drawings on Plan set with the Owner and Engineer 30 days prior to installation.

B. The Engineer shall inspect and approve all LWD pieces and gravel sizes at the source prior to Project site delivery.

END OF SECTION

**TWANOH STATE PARK
LAGOON, SHORELINE AND STREAM RESTORATION**

SECTION 311000 - SITE CLEARING

PART 1 - GENERAL

1.1 SUMMARY

A. Section Includes:

1. Removing identified trees and protecting and identifying trees and other existing vegetation to remain.
2. Removing and protecting native saltwater vegetation to be salvaged, and maintained for replanting.
3. Staking and flagging.
4. Temporary erosion and sediment control measures.
5. Existing utilities.
6. Stockpiling excavated material.
7. Water management.
8. Disposal of waste materials.

1.2 MATERIAL OWNERSHIP

- A. Except for materials indicated to be stockpiled or otherwise will remain Owner's property, cleared material shall become Contractor's property and shall be removed from Project site.
- B. Except for salvaged saltwater vegetation and other materials indicated to be stockpiled or otherwise will remain Owner's property, cleared material shall become Contractor's property and shall be removed from Project site.

1.3 PROJECT CONDITIONS

- A. Traffic: Minimize interference with adjoining roads, walks, and other adjacent occupied or used facilities during site operations.
 1. The north entrance road within the construction area will remain closed for the duration of the project. Parking will be redirected.
 2. Provide alternate pedestrian routes around closed or obstructed traffic ways.
- B. Salvable Saltwater Vegetation: The existing native saltwater vegetation within the new footprint of the saltwater lagoon and tidal channel shall be salvaged, stockpiled, maintained (watered) and replanted.
- C. Utility Locator Service: Notify utility locator service for area where Project is located before site clearing.
- D. Do not commence construction until temporary erosion and sediment control and plant protection measures are in place.

**TWANOHO STATE PARK
LAGOON, SHORELINE AND STREAM RESTORATION**

- E. The following practices are prohibited within protection zones:
1. Storage of construction materials, debris, or excavated material.
 2. Parking vehicles or equipment.
 3. Foot traffic.
 4. Erection of sheds or structures.
 5. Impoundment of water.
 6. Excavation or other soil disturbing activities unless otherwise indicated.
 7. Attachment of signs to or wrapping materials around trees or plants unless otherwise indicated.

PART 2 - PRODUCTS

2.1 MATERIALS

- A. Use materials associated with BMPs for temporary erosion/sedimentation control. Adhere to Washington State DOE and Mason County code requirements.

PART 3 - EXECUTION

3.1 PREPARATION

- A. Protect and maintain benchmarks and survey control points from disturbance during construction.
- B. Locate and clearly identify trees to be removed (7).
- C. Locate and clearly identify trees, shrubs, and other vegetation to remain undisturbed.
- D. Locate and clearly identify vegetation to remain, be retained or to be salvaged.
- E. Protect existing site outside of Work areas from damage during construction.
1. Restore damaged areas to their original condition, as acceptable to Owner.

3.2 TREE AND PLANT REMOVAL AND PROTECTION

- A. General: Protect plants and trees remaining on-site by clearly identifying with high visibility tape.
- B. Trees to be removed will be marked by Engineer.
- C. Repair or replace vegetation indicated to remain or be relocated that is damaged by construction operations, in a manner approved by Engineer or Ecologist.

**TWANOH STATE PARK
LAGOON, SHORELINE AND STREAM RESTORATION**

3.3 SALVAGE SALTWATER VEGETATION

- A. General: When salvaging native saltwater vegetation retain 2 to 3 inches of soil stock on underlying side and stack in layers. Saturate with water 2 to 3 times per week until ready for replanting.

3.4 SALTWATER VEGETATION PROTECTION

- A. General: Protect vegetation remaining on-site by clearly identifying with high visibility tape.
- B. Repair or replace vegetation indicated to remain or be relocated that is damaged by construction operations, in a manner approved by Engineer or Ecologist.
- C. Provide temporary fencing to protect and allow salvaged native saltwater vegetation to re-establish.

3.5 STAKING AND FLAGGING

- A. General: Locate, stake and flag clearing limits.

3.6 TEMPORARY EROSION AND SEDIMENTATION CONTROL

- A. Use BMPs to provide temporary erosion and sediment control measures to prevent soil erosion and discharge of soil-bearing water runoff or airborne dust to adjacent properties and walkways, according to erosion-and sediment-control Drawings and requirements of authorities having jurisdiction.
- B. Verify that flows of water redirected from construction areas or generated by construction activity do not enter or cross protection zones.
- C. Inspect, maintain, and repair erosion and sediment control measures during construction until permanent vegetation has been established. Use BMPs to ensure compliance.
- D. Remove erosion and sediment controls and restore and stabilize disturbed areas.

3.7 EXISTING UTILITIES

- A. Locate, identify, disconnect, and seal or cap utilities indicated to be removed or abandoned in place or relocated.
 - 1. Arrange with utility companies to shut off indicated utilities.
- B. Interrupting Existing Utilities: Do not interrupt utilities serving facilities occupied by Owner or others unless permitted under the following conditions and then only after arranging to provide temporary utility services according to requirements indicated:
 - 1. Notify Engineer not less than two (2) days in advance of proposed utility interruptions.
 - 2. Do not proceed with utility interruptions without Engineer's or Owner's permission.

**TWANOHO STATE PARK
LAGOON, SHORELINE AND STREAM RESTORATION**

3.8 MATERIAL STOCKPILING

- A. Remove sod and grass before excavating material to be stockpiled.
- B. Strip topsoil to depth of 6 inches in a manner to prevent intermingling with underlying subsoil or other waste materials.
- C. Stockpile topsoil away from edge of excavations without intermixing with subsoil. Grade and shape stockpiles of differing material to drain surface water. Cover to prevent windblown dust and erosion by water.

3.9 WATER MANAGEMENT

- A. Construct a flow bypass system including sump, cofferdams, plastic sheeting, pumps and hoses as shown on the Plans to ensure that any surface- or groundwater does not enter or leave (turbid) construction areas. Direct pumped water to a discharge point below the project area at the direction of the Engineer. Supply and stage an emergency backup pump at both sump locations. Flows are expected to be less than 2 cfs.

3.10 DISPOSAL OF SURPLUS AND WASTE MATERIALS

- A. Remove waste materials including trash and debris, and legally dispose of them off Owner's property.
- B. Remove surplus soil material, unsuitable topsoil, obstructions, demolished materials, and waste materials including trash and debris, and legally dispose of them off Owner's property.
- C. Separate recyclable materials produced during site clearing from other non-recyclable materials. Store or stockpile without intermixing with other materials and transport them to recycling facilities. Do not interfere with other Project Work.

END OF SECTION

**TWANOH STATE PARK
LAGOON, SHORELINE AND STREAM RESTORATION**

SECTION 312000 - EARTH MOVING

PART 1 - GENERAL

1.1 WORK IN THIS SECTION

A. Work includes all equipment and labor necessary for excavation (8,900 CY), grading and compaction activities for general re-grading of the entire construction zone as shown on the Plans. Included shall be all grading and site modification procedures for removal of all existing footbridge structures, new footbridge installation including abutments, floodplain expansion, large woody debris (LWD) installation (both shoreline and stream), bioengineered streambank and shoreline installations, gravel berm installation, proper site drainage, and disposal of excess materials (1,869 tons of rip rap and 4,950 CY of native beach material). The Contractor shall be responsible for the satisfactory completion of all earthwork in accordance with the project Plans and Specifications. Section includes:

1. Excavation and grading of existing footbridge and abutment removal and new footbridge and abutment installation footprints, floodplain expansion, LWD installations, gravel berm placement, and bioengineering as shown on the Plans.
2. Stockpiling excavated material for backfilling LWD installation and stockpiling imported gravel and topsoil. Stockpiling LWD.
3. Excavation and grading of saltwater lagoon and tidal connection channel.
4. Stockpiling excavated material from concrete bulkhead removal.
5. Stockpiling excavated material from the lagoon construction.
6. Placing stockpiled native sand and gravel material back into void created by bulkhead removal and compacting.
7. Placing stockpiled native sand and gravel material back into lagoon and tidal channel area for re-grading and compaction.
8. Re-grade disturbed beach areas to original profile.

1.2 RELATED WORK IN OTHER SECTIONS

- A. Section 024113 – Selective Site Demolition
- B. Section 311000 – Site Clearing

1.3 MATERIAL OWNERSHIP

- A. Except for materials indicated to be stockpiled or otherwise remain Owner's property, excavated material shall become Contractor's property and shall be removed from Project site and taken to an acceptable disposal facility.

**TWANOHO STATE PARK
LAGOON, SHORELINE AND STREAM RESTORATION**

1.4 SPECIFIC STANDARDS

- A. Washington State Department of Transportation Standard Specifications.
- B. Mason County Code.

1.5 QUALITY CONTROL,

- A. Washington State Department of Transportation Standard Specifications.
- B. Engineer shall oversee compaction activities.

PART 2 - PRODUCTS

2.1 EXCAVATED MATERIAL

- A. Use suitable materials salvaged from on-site excavation as directed by Engineer for material to backfill LWD installations.
- B. Use suitable native materials mix salvaged from on-site excavation as replacement material to fill void left from concrete bulkhead removal and as supplemental material for use in re-grading the lagoon and tidal channel areas. Prior to filling voids, compacting and regrading beach profile and lagoon and tidal channel, the Engineer shall examine all material.

PART 3 - EXECUTION

3.1 LOCATIONS AND GRADES

- A. All lines and grades shall be constructed as shown on the Plans. The Owner will provide one set of benchmarks and the electronic survey files. The Contractor will provide survey services. Carefully maintain all benchmarks or monuments, if destroyed or disturbed, replace as directed by the Engineer.

3.2 SITE PREPARATION

- A. Complete all clearing, grubbing, excavating, backfilling, and fine grading within the limits of the Work to complete the construction as indicated on the Plans and other items as specified therein.
- B. Where topsoil exists, it shall be stripped from the site and stockpiled until the finish grading is complete; then replaced as directed by the Engineer.
- C. All grading shall be done in a manner so as to provide adequate drainage.

**TWANOH STATE PARK
LAGOON, SHORELINE AND STREAM RESTORATION**

3.3 EXCAVATING

- A. Saltwater lagoon and tidal channel:
 - 1. Final grading and elevations shall match those shown on Plans. Engineer shall indicate where and what materials are to be retained and stockpiled for backfilling designated areas. All other unsuitable excavated material shall become Contractor's property and shall be removed from Project site.
 - 2. Re-grade beach areas disturbed by concrete bulkhead removal to original profile.
- B. Existing footbridge and abutment removal, replacement footbridge and abutment installation, and floodplain expansion and stream channel realignment:
 - 1. Final grading and elevations shall match those shown on the Plans. Engineer shall indicate where and what materials are to be retained and stockpiled for use in designated areas. All other unsuitable excavated material shall become Contractor's property and shall be removed from Project site.

3.5 COMPACTION

- A. Compaction will be achieved by use of a hand operated soil tamper and directed and verified by the Engineer.

3.6 EXISTING UTILITIES AND RELATED FACILITIES

- A. Keep active utilities intact and in continuous operation. Regarding existing underground utilities the Contractor shall:
 - 1. Call the utilities underground location center for field location of utilities;
 - 2. Do not begin excavation until all known underground facilities in the vicinity of the proposed excavation have been referenced on plans, located, and/or marked on the ground.
- B. Location and dimensions shown on the Plans for existing utilities are in accordance with available information without uncovering, measuring or other verification. Utilities/facilities whose underground location can be reasonably determined from existing above ground features shall be considered the same as having been individually marked. In the event the Contractor discovers unknown utilities, they shall:
 - 1. Take reasonable and appropriate steps to avoid damage to the utilities;
 - 2. Promptly notify the Engineer for individual directions.
- C. All costs to repair damage to above ground or known subsurface structures due to operator error will be borne by the Contractor.

3.7 WASTE MATERIAL

- A. Dispose of waste material, and surplus excavated material, away from the site at disposal areas

**TWANOHO STATE PARK
LAGOON, SHORELINE AND STREAM RESTORATION**

arranged and paid for by the Contractor.

END OF SECTION

**TWANOHO STATE PARK
LAGOON, SHORELINE AND STREAM RESTORATION**

SECTION 329300 – LANDSCAPING

PART 1 - GENERAL

1.1 SUMMARY

- A. This section specifies requirements for the following:
 - 1. Constructing bioengineered shoreline and streambanks (3,519 linear feet of coir lifts) as identified in the Plans;
 - 2. Constructing pedestrian beach-access pathways and ADA pads, and an interpretive pad and walkway.
 - 3. Final erosion control for disturbed areas including placing jute mat (4,800 SF) and strawing and seeding.

1.2 DESCRIPTION OF WORK

- 1. Work includes all materials, equipment and labor necessary for installing bioengineering and pedestrian beach-access pathways and ADA pads, and an interpretive pad and walkway as shown on the Plan set.

1.3 PROTECTION OF EXISTING CONDITIONS

- A. Confine work to designated areas. Do not disturb existing vegetation outside of project limit lines. Repair or replace vegetation damaged as a result of Contractor's operation to satisfaction of Owner at Contractor's expense.

1.4 PROVISIONAL AND FINAL REVIEW

- A. Upon completion of all work (if any) required under the contract, the Contractor shall request a provisional inspection (punch list). No partial approvals will be given.
- B. The Contractor shall request a final inspection upon satisfactory completion of all punch list items and any other work required under this contract. Final inspection and acceptance of the work shall establish the beginning of the guarantee period.

1.5 MAINTENANCE

- A. Maintain erosion control areas until date of final acceptance.

PART 2 – PRODUCTS

**TWANOH STATE PARK
LAGOON, SHORELINE AND STREAM RESTORATION**

2.1 TOPSOIL

- A. Use imported topsoil suitable for growing forest plants. Approximately 1,212 CY of soil will be required to construct the bioengineered shoreline and streambanks. The shoreline will require 100 CY for the burlap bags and 720 CY for the coir wraps. The streambanks will require 160 CY for the burlap bags and 232 CY for the coir wraps.
- B. Use 8 rolls of 4' by 225' of jute mat to cover an area of ~7,150 square feet above bioengineered shoreline reach.

2.2 FERTILIZER

- A. No fertilizer shall be used.

2.3 SEED AND STRAW

- A. Use weed free straw and native seed mix for erosion control.

2.4 SHORELINE AND STREAMBANK BIOENGINEERING

- A. Use 13' X 165' - D-900 Coir material (22 rolls), 14" X 26" - 10 oz. Plain Burlap Sandbag (no plastic) with tie string attached (12,000 bags) and 1.5" X 1.5" wooden stakes (12" & 18" in length – 4,375 of each size for a total of 8,750). Each burlap sandbag holds ~5/8 CF of soil.

PART 3 – EXECUTION

3.1 FINISH GRADING

- A. Establish finish grades in accordance with elevations shown in the Plans, ensuring that no pockets or any other surface obstructions to positive drainage are present. Ensure positive drainage. Obtain approval of finish grades prior to erosion control.

3.2 SHORELINE AND STREAMBANK BIOENGINEERING

- A. Install coir wraps, soil-filled burlap sandbags, backfill, tamp topsoil with a handheld vibratory compactor in 6" lifts to 80% compaction and then stake as directed by Engineer or Ecologist.
- B. Plant native species as shown on the Plans into the bioengineered streambanks.

3.3 DISPOSAL OF SURPLUS DEBRIS AND WASTE MATERIALS

- A. Remove surplus vegetative debris, excess topsoil or other waste materials and legally dispose of them off Owner's property.

**TWANOHO STATE PARK
LAGOON, SHORELINE AND STREAM RESTORATION**

- B. Separate recyclable materials produced during site clearing from other non-recyclable materials. Store or stockpile without intermixing with other materials and transport them to recycling facilities.

END OF SECTION